

**NUCLEAR ENERGY AGENCY
COMMITTEE ON THE SAFETY OF NUCLEAR INSTALLATIONS**

Advancing the Robustness of Electrical Power Systems of Nuclear Power Plants

This document is available in PDF format only.

JT03510625

COMMITTEE ON THE SAFETY OF NUCLEAR INSTALLATIONS

The Committee on the Safety of Nuclear Installations (CSNI) addresses Nuclear Energy Agency (NEA) programmes and activities that support maintaining and advancing the scientific and technical knowledge base of the safety of nuclear installations.

The Committee constitutes a forum for the exchange of technical information and for collaboration between organisations, which can contribute, from their respective backgrounds in research, development and engineering, to its activities. It has regard to the exchange of information between member countries and safety R&D programmes of various sizes in order to keep all member countries involved in and abreast of developments in technical safety matters.

The Committee reviews the state of knowledge on important topics of nuclear safety science and techniques and of safety assessments, and ensures that operating experience is appropriately accounted for in its activities. It initiates and conducts programmes identified by these reviews and assessments in order to confirm safety, overcome discrepancies, develop improvements and reach consensus on technical issues of common interest. It promotes the co-ordination of work in different member countries that serve to maintain and enhance competence in nuclear safety matters, including the establishment of joint undertakings (e.g. joint research and data projects), and assists in the feedback of the results to participating organisations. The Committee ensures that valuable end-products of the technical reviews and analyses are provided to members in a timely manner, and made publicly available when appropriate, to support broader nuclear safety.

The Committee focuses primarily on the safety aspects of existing power reactors, other nuclear installations and new power reactors; it also considers the safety implications of scientific and technical developments of future reactor technologies and designs. Further, the scope for the Committee includes human and organisational research activities and technical developments that affect nuclear safety.

Foreword

Working under the mandate of the Committee on the Safety of Nuclear Installations (CSNI), the Nuclear Energy Agency (NEA) Working Group on Electrical Power Systems (WGELEC) aims to advance understanding of safety issues related to electrical systems of nuclear installations in order to enhance safety and improve the effectiveness of regulation in NEA member countries.

One of the initial tasks of the WGELEC since it was launched following a workshop organised by the CSNI in 2014 [1] was the identification of good practices for advancing electrical power system robustness in case of deviations from their normal operating conditions. This task was undertaken because some previous events such as a switchyard-induced voltage surge event at the Forsmark Nuclear Power Plant in 2006 or the Fukushima Daiichi Accident in 2011 showed how important the robustness of electrical power supplies is for nuclear safety. It was considered that adopting a plant-centred view might provide additional insight into aspects of the electrical power system design in order to increase the robustness against deviations from normal operation of the electrical power system. The aim of this task was to identify possible practices for the design and operation of electrical power systems, as well as other possible diverse power systems, supporting plant safety functions. This may then enhance decision-making in the design, operation and safety justification of such systems.

To perform this activity, a detailed questionnaire was developed regarding the design practices of power supplies supporting safety functions. Particular focus was placed on possible robustness enhancements to limit the impact of deviations from normal operation of the electrical power supply. The questionnaire was circulated to the WGELEC's participating countries and 13 answers were received from regulators, technical support organisations and licensees, representing 10 countries. After several rounds of discussions to seek clarifications and additional detail, the WGELEC summarised the collected information into this report, titled "Advancing the Robustness of Electrical Power Systems of Nuclear Power Plants".

Table of contents

Executive summary	6
List of abbreviations and acronyms.....	8
Glossary.....	10
1. Introduction	11
1.1. General.....	11
1.2. Objective and scope of the work.....	11
1.3. Format of the report	12
1.4. Process followed in the work.....	12
2. Context	14
3. Normal and degraded power supplies	16
3.1. Definitions	16
3.2. Degraded power supplies.....	16
3.3. Unanticipated disturbances	18
4. Power system design.....	20
4.1. System design	20
4.2. Design variations	23
4.3. Questionnaire synthesis	27
5. Further work.....	36
6. Conclusion.....	37
7. References	38
List of tables	
Table 1.1. Questionnaire respondents (in alphabetical order).....	12
List of figures	
Figure 4.1. Simplified schematic power system.....	21
Figure 4.2. Power supply interfaces of a “typical” power system design	22
Figure 4.3. Extended conceptual schematic power system design.....	23

Executive summary

Background

The NEA Working Group on Electrical Power Systems (WGELEC) was launched following a workshop organised by the NEA Committee on the Safety of Nuclear Installations (CSNI) in April 2014.

One of the major conclusions of this workshop was that many of the recent disturbances for example a switchyard fault at Forsmark or the Fukushima Daiichi accident, in electrical power systems that propagated to redundant safety trains in nuclear power plants were of unidentified character and could not have been anticipated from previous events. It was recognised that there was a need to raise awareness of the importance of studying system topology and characteristics to further enable informed decisions on the impact of design choices on plant response when subjected to an anticipated or unanticipated disturbance. It was considered particularly important to avoid, as far as reasonably practicable, cliff-edge effects by enhancing the robustness and resilience of the systems.

As a result, the initial WGELEC programme of work proposed carrying out a survey on designs to identify common design practices and design variations among electrical systems as well as any relevant experiences or characteristics.

Objective

The aim of this report is to examine whether there are any international variations in the electrical power system designs (“design variations”) of nuclear power plants that affect the system response when subjected to relevant disturbances. The ambition is to collate views and experiences in this area or suggestions for further investigations, providing an overview to stimulate discussions on the utilisation of the “best available technology”.

For this first study, the scope was defined as “power supplies in general but electrical power supplies in particular”. The rationale was that the energy required to fulfil necessary safety functions may be provided by any type of energy source and a key strategy to mitigate unanticipated failure modes is to provide as strong independence as reasonable between redundant functions, with a diversification of energy sources potentially providing a strong decoupling of failure modes.

Process

A questionnaire, including an explanation of the rationale of the survey, was circulated to CSNI participants to identify design practices of electrical power systems within nuclear power plants and particular design variations that may not be commonly known elsewhere.

Thirteen answers were received from regulators, technical support organisations and licensees, representing ten countries. The collected information was analysed and summarised to reach the conclusions presented below.

Conclusions

- The power supply of any nuclear power plant safety function consists of a source, route and load. There are numerous sources and loads but routes are normally common. Most or all plants rely on the external grid as the preferred power supply to all plant functions, including safety functions. The redundant electrical trains will only be electrically isolated if a fault is detected in the preferred power supply.

This assumes that electrical disturbances can be anticipated, that protection systems have been properly configured and that they function correctly to achieve robustness.

- Power supplies in a nuclear power plant can be distinguished as normal or degraded power supplies. The latter can be further divided into those affected by anticipated or unanticipated disturbances. Unanticipated disturbances are challenging to work with and it is necessary to consider how system properties affect plant behaviour. The survey identified no general strategies to manage robustness against unanticipated disturbances, but a few specific considerations were discovered.
- There are some design variations in the electrical power supplies of nuclear power plants affecting plant robustness, most related to the utilisation of the standby grid or number and types of emergency power sources.
- Some plants have a degree of diversity in their power supply by utilising steam-driven pumps requiring only auxiliary power from the interconnected electrical system to function.
- No fully independent power supplies have been identified in the survey, with the exception of a few plants islanding diesel generators in case of severe weather warnings (e.g. lightning).
- Further work is necessary to effectively manage unanticipated disturbances in the electrical systems of nuclear power plants, especially in plants with a low degree of diversification of power supplies.

List of abbreviations and acronyms

AAC	Alternative AC
AC	Alternating current
AOO	Anticipated operational occurrence
CAPS	CSNI activity proposal sheet
CCF	Common cause failure
CSNI	Committee on the Safety of Nuclear Installations (NEA)
DBA	Design basis accident
DC	Direct current
DEC	Design extension condition
DPS	Degraded power supplies
EDG	Emergency diesel generator
HV	High voltage
I&C	Instrumentation and control
IAEA	International Atomic Energy Agency
INES	International Nuclear and Radiological Event Scale
LCO	Limiting conditions for operation
LV	Low voltage
M-G	Motor-generator
MV	Medium voltage
NEA	Nuclear Energy Agency
NPS	Normal power supplies
OPC	Open phase conditions
PPS	Preferred power supply
PSS	Power system stabiliser

SA	Severe accident
SBO	Station Blackout
UPS	Uninterruptible power supply
WGELEC	Working Group on Electrical Power Systems (NEA)
WGRISK	Working Group on Risk Assessment (NEA)

Glossary

Abnormal operation	Not a normal operation, for example AOO, DBA, DEC
Auxiliary power	Power required for a function other than the prime mover of the function (e.g. I&C required for the function such as control logic and actuators such as valves)
Electrical Power Supply	A power supply utilising electrical power
(power) source	A source of power (generator, battery, pressurised tank, etc.)
(power) route	A route to distribute power from a source to a consumer
(power) load	A consumer of power, may also be referred to as a sink
Normal operation (NO)	Operation within specified operational limits and conditions
Power operation	Operation at power (subset of normal operation)
Power Supply	Source, route and load
Resilience	Breaking under disturbances without unduly detrimental effects
Robustness ¹	Being subjected to disturbances without malfunctioning

1. In this report, the term “robustness” may generally be interpreted as “robustness and resilience”, as these two are closely related.

1. Introduction

1.1. General

In recent years, the topic of robustness of power supplies in nuclear power plants has gained increased attention. Various initiatives have been undertaken in international forums under the aegis of the Nuclear Energy Agency (NEA), such as the Defence in Depth of Electrical Systems (DiDELSYS) project, which was followed by Robustness in Electrical Systems (ROBELSYS). One of the important conclusions from the ROBELSYS workshop is that “Severe accidents result from unexpected events that were not considered or were discounted in the plant design or operations and that were not sufficiently mitigated by defence in depth measures” [1]. Two clear examples of such unexpected events are the loss of two safety trains in the Forsmark Nuclear Power Plant in 2006 [2] and the loss of several safety-related loads in the Byron Nuclear Power Plant in 2012 [3]. Although neither of these events progressed to severe accident conditions, they underline the limitations of predictability of plant behaviour. While these two events may serve as useful references, it is also important to note that other occurrences of similar nature have been reported in the DiDELSYS and ROBELSYS workshop proceedings [1, 4], which show that preventative measures identified for one situation have not been effective for slightly different situations. Most, or all, of these events can however be characterised as unanticipated degrading electrical disturbances able to affect redundant safety trains due to having a common point of coupling.

When the NEA Working Group on Electrical Power Systems (WGELEC) was created, performing a survey on design practices and experiences of electrical systems was one of the activities proposed in the initial programme of work. The survey results have been used as input to Chapter 5 of this report.

1.2. Objective and scope of the work

Preventing unexpected challenges to the safety systems of a plant presents particular difficulties for the very fact that the challenges are unanticipated. It is therefore beneficial to have a complementary approach to limit the consequences of unanticipated behaviours by increasing the knowledge of the system properties through example experience feedback [5] and simulations [6]. This report introduces a possible approach to advancing safety function robustness by considering how properties of the power system, which typically is electrical, influence the sensitivity to unanticipated disturbances.

The entry assumptions for the report are that:

- Learning from experience following events is not sufficient to prevent other similar types of events. A complementary approach where system properties are considered could be useful. This is discussed and exemplified in the report but an in-depth analysis of properties is beyond the report’s scope.
- A more systematic approach to determine the sensitivity of the plant to electrical disturbances, in particular through common coupling points, may be beneficial. A possible approach is exemplified in the report.

- Plant designs have varying properties that may be beneficial or detrimental, according to the considered situation, and an ideal design or firm solution for all situations, is not realistically achievable. Therefore, the purpose of the report is not to provide any design recommendation and should not be interpreted as inferring judgement on the suitability of any particular design. However, it is expected that some design variations with insights not commonly known and discussed could be identified.

This report is focused on power reactors only (excluding all other types of nuclear installations). However, the approach could likely be generalised. In addition, the main purpose is to reduce the likelihood that safety functions fail due to occurrences in the electrical power system. Therefore, while the main focus in this report is the robustness and resilience of the electrical power system, to some extent the possibilities to reduce the reliance on the electrical power system (e.g. through other types of power systems, such as steam-driven pumps) to perform safety functions are mentioned.

1.3. Format of the report

The report begins by laying out the context in which this report came about. It then introduces normal and degraded power supplies and considers the unanticipated degrading of power supplies. A subsequent chapter outlines power system designs, including possible design variations that may be considered. The report is wrapped up with a conclusion. Detailed summaries of the survey responses can be found in Chapter 5.

To preserve confidentiality, no information herein is attributed to a particular respondent, but an indication is given on how widespread any particular design variation is, if at all. As each safety case is unique, with differing plant- and site-specific characteristics that are necessary to consider in a balanced design, the information herein should be used with this caveat in mind.

1.4. Process followed in the work

The work presented in this report is one of the three initial activities carried out by the newly created WGELEC. The CSNI process selected is inspired by those used for the Working Group on Risk Assessment (WGRISK) activities.

After the approval of the CSNI Activity Proposal Sheet (CAPS), the activity lead produced a draft questionnaire, which was sent to the working group members for review and afterwards and also to other CSNI participating countries as well.

The organisations providing answers to the questionnaire are listed in Table 1.1.

Table 1.1. Questionnaire respondents (in alphabetical order)

Forsmark, Licensee, Sweden
Fortum, Licensee, Finland
GRS, Regulator (technical regulatory support), Germany
IRSN, Regulator (technical regulatory support), France
KINS, Regulator, Korea
Krsko, Licensee, Slovenia
MHI, Licensee, Japan

NRC, Regulator, United States
Oskarshamn, Licensee, Sweden
Ringhals, Licensee, Sweden
STUK, Regulator, Finland
Torness, Licensee, United Kingdom
Tractebel Engineering, Licensee, Belgium

The reader should note that in some countries, the respondent made a synthesis of the activities performed by the different organisations in the country, whereas in other countries different organisations each provided their own answers.

2. Context

In a nuclear power plant, there are a number of barriers and safety functions that are implemented, according to a defence-in-depth concept, to cope with both normal and abnormal operational situations. The plant safety functions are commonly divided into three main groups: control of reactivity, cooling of radioactive material and confinement of radioactive sources. All these functions require a source of energy delivering power, a motive force, over time to fulfil their tasks. In some cases, they require an inherent capability to use bound energy, or to bind energy, to fulfil their tasks (i.e. more or less “passive” systems). The power supply to the safety functions is therefore critical to achieving the safety functions in both normal and abnormal operational situations. Recently, there has been a noticeable increase in interest regarding so-called passive systems, where the design incorporates the inherent capability to use accumulated energy, such as gravity, or store delivered energy, such as heat sinks like isolation condenser pools. This report will not elaborate on these matters but rather investigate the characteristics of the other option – active systems.

An active system can broadly be defined as a system that relies on an auxiliary system providing the energy required, or energy accumulation capability required, to fulfil the required task. This has been, and is, a very common design choice for safety functions and the most common source of energy is electrical energy. With this design choice comes the requirement for a reliable and sufficient capability to generate, distribute and deliver the energy to the systems carrying out the safety functions. That is, the power source, route and load must be intact.

Electrical systems are generally interconnected for various reasons such as availability, flexibility and practicality. This leads to particular challenges when considering independence of redundant safety functions, relying on more or less active protection devices, and puts a high expectation on the design and designer to foresee what challenges may arise, detect every situation correctly and act quickly to ensure common cause failures are prevented. This can be particularly challenging when considering the number of free variables (voltage, current, amplitude, frequency, waveform, phase order, phase angle, harmonics, positive- negative- or zero-sequence, etc.) and with the propagation of electrical disturbances being practically instantaneous².

A number of occurrences of electrical origin have challenged plant safety and received increased attention in the last decade. It has proven difficult to foresee possible failure modes proactively, partly due to significant human factor influence in enabling those occurrences. Therefore, it could be useful to consolidate experiences in assuring the independence of a system while accepting that unforeseen or unexpected disturbances may occur.

The electrical disturbance at the Forsmark Nuclear Power Plant in 2006 [2], which caused the core cooling of the nuclear plant to malfunction in two out of four safety trains, helped renew attention on electrical supplies robustness. The event was rated as two on the international INES scale and a complete understanding of how the event progressed has not yet been determined as of the writing of this report. In particular, there is no definitive

2. Typically 0.7-0.9 of light speed in copper conductors.

answer to why the other two trains were unaffected by the event and how large the margin was to a complete failure of the core cooling.

Based on the experience of the Forsmark event, a series of meetings and discussions were held under the Defence in Depth of Electrical Systems (DiDELSYS) heading. Discussions were held on various topics on electrical systems behaviour, as summarised in [4].

After the Fukushima Daiichi Nuclear Power Plant accident in 2011, DiDELSYS was found to not appropriately account for external hazards, and the activity Robustness of Electrical Systems of NPPs in Light of the Fukushima Daiichi Accident (ROBELSYS) was initiated [1]. Since the initial cause of this event was non-electrical (a tsunami), this event is not a key input for this report, which limits itself to the electrical properties of the electrical system and the resilience of such a system to common cause failures of electrical origin. Nonetheless, it is important in the design of the defence-in-depth of nuclear power plants to appropriately consider hazards of non-electrical origin that may challenge the capability of electrical systems. Post-Fukushima measures have included extensive national “stress tests”, which may be consulted for approaches [7].

In 2012, another type of electrical disturbance, a phase disruption, occurred at Byron nuclear power plant [3], which disabled the electrical core cooling to the plant. Eventually manual disconnection of the faulty source restored the functions at the plant. In 2013, a phase disruption also occurred at Forsmark, and further investigations revealed that a phase disruption had previously occurred at Dungeness in 2007, but with a graphite core and natural circulation cooling properties the design is less dependent on active cooling and the event did not have a major impact on the discussions of electrical power system robustness.

Nuclear power plants are connected to the off-site grid to deliver the produced energy on the electricity market as well as to provide electrical power for internal needs, and it is standard practice to use the off-site power supply as the “preferred power supply” for safety functions as well. The electricity markets of many countries have been deregulated since many nuclear power plants were built, resulting in an increase in interfaces within the same infrastructure. There has also been an increase in the penetration of non-dispatchable low-inertia generation and complex power electronics, in generation as well as transmission and distribution. Further changes can be anticipated, as many initiatives to meet the UN sustainability goals involve electrification. This increases the challenge to fully predict and anticipate the transmission system characteristics and behaviour and adapt nuclear power plants’ internal electrical system resilience accordingly.

This report will consider the responses to a survey sent out to NEA member countries regarding design, or other, experiences having an impact on the robustness and resilience of the power supply function. The report intends to provide a discussion regarding approaches in the design of active systems, which have a number of beneficial properties, and highlight that there is not only the difference between active and passive systems to consider but possible variations within active system designs as well. The report will not promote any particular design choices and should not be used as advocacy for a particular design. The design choices must be made by the responsible designers to be appropriate for the overall plant design and siting, commensurate with relevant regulations.

3. Normal and degraded power supplies

This section will introduce the terms normal and degraded power supplies, which will be used to draft an overarching framework to support the discussion on power supply characteristics. This framework will then be used to illustrate how identified challenges to the power system constitute a more or less complete subset of states that could occur. The residual aspect of degraded power supplies, which is not easily identifiable or predictable, is then defined as unanticipated degrading power supplies.

3.1. Definitions

During the design of a nuclear power plant, consideration is given to what challenges or events the plant should be able to endure. These events may be of internal origin, i.e. something that occurs within the plant, or external, such as earthquakes. Events that should be considered are those that may change the plant state, i.e. change the behaviour of the plant processes in a significant way. Any given plant state can be characterised by bounding conditions, which define the permissible variations while in a given plant state. The “limiting conditions for operation” (LCO) are such a set, defining the permissible limits for operation of the plant and the measures to be taken should these be exceeded.

During operation of a nuclear power plant, the process is basically the reverse – the condition of the plant is continuously measured and monitored in the control room. Should some limits be exceeded, it is usually not known what the cause is before an investigative root cause analysis is carried out. The continuous monitoring of the plant allows conclusions on the plant state or its behavioural pattern.

When discussing plant characteristics, the state therefore refers to the pattern of behaviour, which is affected by the properties of structures, systems and components within the plant. Clearly some patterns of behaviour are generally more desirable than others, i.e. the avoidance of any sudden (negative) changes while maintaining a responsive system (for positive changes).

To maintain focus on behavioural patterns within the power supply, the following definitions of normal and degraded power supplies will be used in this report:

Normal power supplies (NPS) – a power supply system that is in a state enabling supported systems to function as intended.

Degraded power supplies (DPS) – a power supply system that is not in a state enabling supported systems to function as intended.

It may be noted that the above definition of degraded power supplies is practically equivalent to the definition proposed in [8], where DPS is defined as “a state where connected components may malfunction”.

3.2. Degraded power supplies

It is necessary to further elaborate the definition of degraded power supplies to make the term workable. It is usually fairly well established what every component in the electrical system should be able to withstand. Therefore, the design of the system incorporates

various protective and limiting measures to prevent the component from being exposed to such conditions.

Practical examples are surge arresters, over- and under-voltage protections, fuses and unbalance protections. These protect the systems and components against certain conditions of degraded power supplies. Therefore, they could be seen as a more or less complete protection system against degraded conditions in the power supply. Degraded power supply conditions can be broken down as below³ (noting that this is a conceptual explanation, which should not be considered complete and the actual breakdown may vary depending on system design).

- Degraded electrical power supply
 - Conductive disturbances
 - Degraded voltage
 - Over-voltage
 - Under-voltage
 - Voltage unbalance
 - Degraded current
 - Overcurrent
 - Degraded frequency
 - Over-frequency
 - Under-frequency
 - Harmonics
 - Radiative disturbances
 - *Electromagnetic interference (EMI)*
 - *Electromagnetic pulse (EMP)*
- Degraded steam power supply
 - *Degraded steam pressure*
 - *Overpressure*
 - *Underpressure*
 - *Pressure oscillations*
 - *Degraded steam quality*
 - *Overmoisture*

It should be noted that the inclusion of non-electrical power supplies in the list is intended to illustrate that other sources of power supply may also be utilised, each of which may have their own limitations. Radiative electrical disturbances may also cause problems in a plant and need consideration of their own, but as the recently occurred challenging

3. Properties in italics are not in the scope of this report.

disturbances have been electrical conductive disturbances, this category is the focus of the report.

Regardless of how such a breakdown is done, some assumptions will be made that discount some situations as not plausible and there will be limitations, practically and technically, in identifying all possible states of the system characteristics. Such exclusions can be referred to as “unanticipated degrading conductive electrical power supplies”, or abbreviated for the purpose of this report as “unanticipated disturbances”.

3.3. Unanticipated disturbances

The anticipated states of degraded power supplies should generally be incorporated in the design of the protective scheme of the system if considered enough of a risk, i.e. the frequency and consequences for the plant of such an event occurring are not negligible.

The unanticipated states of degraded power supplies could be unknown, unidentified or unexpected behaviours in the electrical system or unknown, unidentified or unexpected sensitivities of the components used. All these situations could be considered to be unanticipated degrading power supplies. The majority of electrical disturbances of safety significance that have occurred since the Forsmark event in 2006 have been of this type, which warrants further consideration of how this particular group of disturbances may be mitigated.

Designing for unanticipated disturbances in general is impracticable, so it is useful to focus more narrowly. It could be reasonable, for example, to focus on disturbances that are of an electrical and conductive nature. Possible ways to avoid such disturbances are to:

1. ensure disturbance propagation is not possible, which may be achieved by
 - a diversification of the power supply to non-electrical systems, or
 - b provision of absolute independence by not electrically interconnecting redundant subsystems, i.e. not having a conductive route through a point of common coupling;

and to a lesser extent:

2. enhance the robustness and resilience to such disturbances, which may be achieved by
 - a increasing the transient damping characteristics of the system, e.g. by increasing the distance to the point of common coupling or using components with enhanced transient damping characteristics, and
 - b avoiding identical properties in redundant interconnected systems to ensure different system behaviours.

Additionally, it may be useful to characterise unanticipated disturbances in the electrical systems as either immediate disturbances, which almost immediately can disable interconnected objects, or remaining disturbances, which remain undetected and can disable any objects being interconnected to the point of common coupling. The disturbances at the Forsmark Nuclear Power Plant in 2006 [2] and at the Byron Nuclear Power Plant in 2012 [3] are examples of each kind. If the disturbance is of an immediate nature, it is enough to ensure that not all redundancies are interconnected when the disturbance occurs, whereas if it is a remaining disturbance it must be ensured that not all redundant functions are sequentially connected to the faulty power supply. Some design

considerations may be effective in managing either immediate or remaining disturbances while others can be effective in managing both types.

4. Power system design

The previous section discussed the rationale for considering degraded power supplies in general and it was concluded that some plant disturbances would remain unanticipated.

In the first quarter of 2017, a survey was carried out with a questionnaire sent to all NEA member countries and 13 responses were received from 10 countries. From these responses, it is quite clear that the power system configuration and operation principles generally does not display major variations. In the majority of cases, it seems that preference is given to connecting all safety trains to a single point of common coupling in normal operation and remain in such a configuration unless an issue with the power supply is correctly detected. This section summarises typical commonalities in power system design as well as design variations that have been discussed or presented in the survey.

4.1. System design

Before further discussing power system design in nuclear power plants it is useful to define which aspects of system design are relevant. Broadly speaking, system design could be considered as the process of defining and developing systems to satisfy specified requirements of the user. This allows for great variations in how the design is eventually implemented. To obtain an appreciation of how design variations affect the system behaviour, a systems engineering task is carried out to define and characterise the interactions between subsystems and components. During the process, certain properties of the system will be better understood and with design variations these properties may be altered. It is important to note that several different variations may fulfil the user requirements, which will enable an array of viable design implementations but with different characteristics.

When choosing between viable designs of a system it is important to not only ensure that the requirements are met but also that the characteristics of the system are desirable. A robust design is such that its response characteristics do not allow for unduly rapid variations in the output.

4.1.1. Simplified power system design

At the most basic level, a typical nuclear power plant (electrical) power system may be illustrated as in Figure 4.1. In this view, there are two main sources of electrical power, (1) the off-site grid and the main generator and (2) one safety-related source of electrical power, usually comprised of diesel generators.

This simple view is representative for a large number of nuclear power plants at a principal level and particularly useful in illustrating the primary sources and usual routing to safety loads. As long as (1) is not detectably faulty, this will source the power necessary for plant functions, including safety functions, in all plant states. Only if (1) is detected to be faulty will action be taken to isolate the safety-related busbars to source the necessary power for required functions from (2). Usually, (1) consists of one main and one standby off-site grid connection and (2) consists of two to four diesel generators. In such a design, fault detection must be accurate and act correctly in adequate time and the common parts of the systems must remain available when switching sources, withstanding the impact of the initial

disturbance. The point of common coupling becomes a critical link in the power system infrastructure.

Figure 4.1. Simplified schematic power system

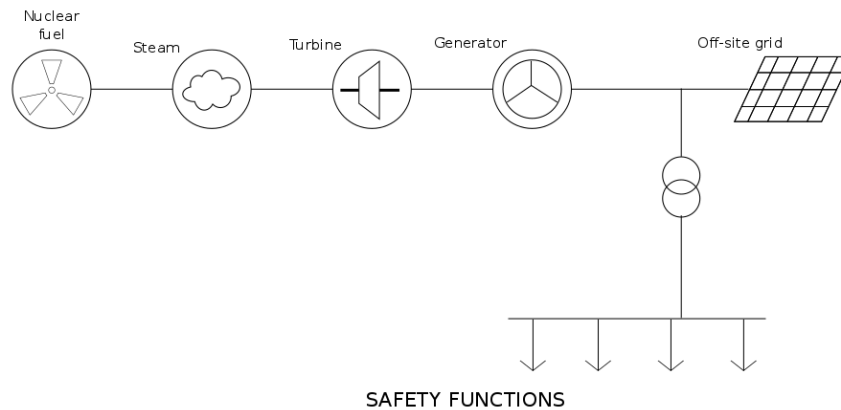

4.1.2. Typical power system design

A typical light-water nuclear power plant is more or less dependent on electrical power for safe operation during normal as well as abnormal operation. The electrical power necessary for auxiliary functions in the plant is taken from either the generator-switchyard interconnection or the switchyard directly, depending on whether a generator circuit breaker exists. This point usually connects to all electric equipment in the plant, during normal as well as abnormal operation, unless a faulty supply can be detected. This concept is usually referred to as “Preferred power supply (PPS)” [9]. In the plant distribution system there are usually 2-4 safety busbars that are protected by “isolation devices” [10], commonly fuses and circuit breakers actuating on predefined low voltage or frequency that can isolate the busbars if a faulty supply is detected and energise the safety busbars from another power supply, usually a dedicated diesel generator for each safety busbar.

Within the safety power system, there are usually dedicated batteries in each train to ensure uninterrupted supply during such a switchover. The battery system usually powers inverters to provide AC power of lower voltages, which is necessary for most computerised control systems, as well as other I&C equipment.

Many plants include steam-driven pumps as a diverse means for emergency core cooling. Their operation usually depends on available battery power and inverters, but does not require the diesel-backed safety busbars to be available⁴.

The two central commonly applied concepts are:

- I. preferred power supply, i.e. staying connected to a common point of coupling unless faults are detected;
- II. isolation device, which act on some predefined electrical conditions, usually overcurrent, under-voltage and under-frequency.

4. For as long as battery capacity is sufficient, usually a few hours.

Figure 4.2 provides a high-level outline of power supply interfaces in a “typical” power system.

Figure 4.2. Power supply interfaces of a “typical” power system design

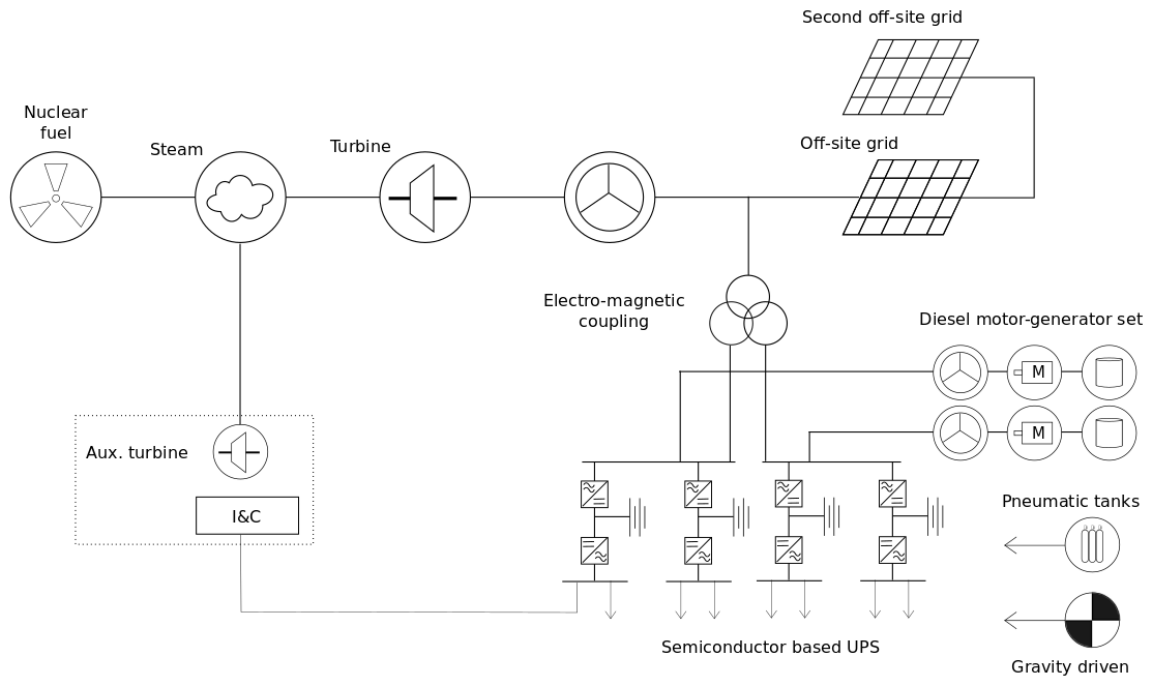

4.1.3. Extended power system design

An expanded conceptual view of possible nuclear power plant power supplies is illustrated in Figure 4.3. It shows some of the possible design variations that will affect how disturbances may propagate from a point of common coupling, though it should be noted that it is not a typical or particularly realistic design as it includes all variations for an individual plant.

There are a number of possibilities to extract energy from the primary source of energy, i.e. the fuel in the reactor, other than drawing electricity from the main generator coupled to the grid. Steam could be tapped from the main steam lines and used for independent systems, or rotational energy could be tapped from the turbine-generator shaft. Other means would be to use auxiliary independent sources of energy, such as gas- or diesel engines, as well as stored energy in compressed gas cylinders or batteries. The configuration of the power supply (sources, routes and loads) in normal as well as abnormal operation need consideration with respect to points of common coupling, interdependencies between redundant systems and the response to unanticipated disturbances.

Figure 4.3. Extended conceptual schematic power system design

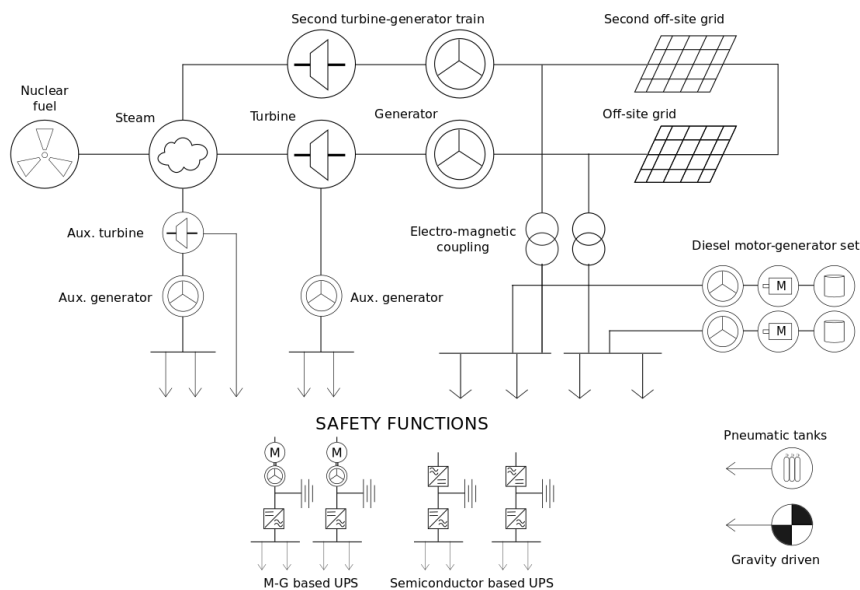

4.2. Design variations

The first question in the survey was about the dependence of safety functions on motive (actuating) power and auxiliary power. Because it is demanding to fully answer such a question within the framework of a survey, complete answers were not expected. Rather, the aim was to understand whether both types of power are usually required for the function to work as intended. While a function may not depend on electrical motive power, it may still depend on auxiliary (I&C) power to function correctly. IAEA-TECDOC-626 [11], published in 1991, proposes a categorisation of passive systems from A to D, where A is the most passive and D the least passive. A category D system is exemplified as requiring single-action initiating auxiliary power. Such a function may be an isolation condenser, which requires auxiliary power for initial valve alignment. Control rods can usually be considered to belong to this category.

As the energy requirement to carry out the intended function increases, it becomes more difficult to design self-contained systems. This is further discussed in the Energiforsk report 2018:519 [12] where the energy requirement of emergency core cooling and residual heat removal is shown to be several orders of magnitude (~1 000 times) larger compared to containment isolation and reactivity control.

Because containment isolation and the reactivity control safety function require far less energy than the emergency cooling function, they are relatively easier to design as independent functions with self-contained energy supplies. Therefore, having the highest energy requirement among the heat removal safety functions, these will generally be the focus for discussions on design variations.

The following subsections introduce some possible variations in the design of the power supply that were identified in the survey or discussed during working group meetings and may be considered to affect plant behaviour if subjected to unanticipated disturbances. A more exhaustive summary of the responses to the questionnaire follows thereafter. The section does not attempt to be complete or favour any designs and should be understood as

providing examples of design variations that may enhance the resilience of the power supply function in certain circumstances. The design variations in the following subsections seem to be more or less common and in some cases only conceptual, rather than implemented, and are labelled in the text as “many”, “some”, “few” or “none”.

The numbers in parenthesis next to the following sub-section titles refer to the related measures to avoid unanticipated disturbances of electrical and conductive nature, as per section 3.3.

4.2.1. Diversified power supply (3.3 1a)

In Section 4.3, a few principles to avoid unanticipated disturbances are proposed, where 1a (in section 3.3) suggests diversification to non-electrical power supplies. In the survey, many respondents reported using steam-driven systems in addition to electrically powered systems. Variations reported consist of a steam-driven pump in systems such as auxiliary (or emergency) feedwater and high-pressure coolant injection. These systems, however, still require continuous electrical auxiliary power, derived either from DC-systems or AC (UPS) systems normally interconnected through a point of common coupling and backed by batteries.

Reactivity control and containment isolation usually have diversified power supplies by using either gravity or pressure tanks as motive power, which actuate on loss of auxiliary electrical power in a so-called “fail-safe” manner.

In summary, many respondents reported a diversified motive power supply but no respondents reported a diversified auxiliary power supply.

4.2.2. Absolute independent electrical power supply (3.3 1b)

An absolute independent electrical power supply, where there is no conductive route between redundant safety trains in all operational states, has not been identified in the survey. All designs and operational principles seem to rely on the commonly accepted principles of “preferred power supply” and “isolation device”, as mentioned in Section 4.1.2. Redundant electrical systems are normally interconnected as long as a degraded power supply is not detected and relies on isolation devices to protect loads and routes from harmful effects should degraded power supplies occur, such that they can be reused and supported by an alternative power source that is not detectably faulty.

However, two respondents mentioned that a single safety train may be isolated and powered by the emergency diesel generators (EDGs) pre-emptively during operational states, when there is an elevated risk of, for example, lightning strikes, which would then constitute an absolute independent power supply for that train.

A few respondents reported using motor-generator (M-G) sets in the plant design, which can eliminate the conductive path to the supported subsystems and may, coupled with an emergency power source, be used to provide an absolute independent electrical power supply. However, no elaborate discussions on their utilisation were provided.

An absolute independent power supply consists of a source, route and load that is not interconnected during any operational state. Each may be considered to have a certain degree of “re-usability”, such that its integrity is assumed to be unchallenged by the disturbance requiring the safety function to actuate. For example, if the route is assumed re-usable, it may be adequate to ensure that the sources and loads are absolutely independent. An example of such a concept would be to always supply emergency loads

from emergency sources during demand, i.e. an early actuation of the emergency power system. The survey did not identify any experience of this, however.

Below, each part of the power supply is considered individually.

Source

At least one alternative power source, the EDG, is always absolutely independent from the point of common coupling, except for in some testing scenarios, which usually limit the redundancy to one.

Some respondents reported either additional alternative power sources with absolute independence or, in a few cases, sources other than diesel generators. This is further discussed below in 4.3.3.

Route

No absolute independent route seems to be utilised in any designs and the same routes are usually more or less reused when the emergency power supply is required. It may be reasonable to assume passive components in the route, e.g. conductors, are inherently robust, while more complex equipment in the routes, e.g. converters, require more reassurance.

Load

Safety loads are normally not connected to the electrical system in normal operation and may as such be seen as absolutely independent. In emergency operation, however, these are normally aligned to the interconnected electrical system and will then share a point of common coupling.

4.2.3. Absolute independent electrical power source (3.3 1b - power source only)

Emergency diesel generators are used by almost all plants covered by the survey and usually number from two to four, with some exceptions with six to eight EDGs. In the latter cases, the original plant design usually had fewer EDGs, but additional requirements on stricter separation requirements, or more onerous hazards over time that resulted in additional EDGs being installed.

At least one site is reported as having on-site hydro-generators instead of EDGs.

Some plant designs in the survey are reported using a steam-driven electrical generator that starts and aligns to support part of the electrical system if other sources fail. However, some difficulties have been encountered with this design, such as reliance upon steam availability and quality as well as difficulties in regulating the device, leading to recurring over-speed tripping at start-up.

Some plant designs have other absolute independent power sources such as alternative AC (AAC) supplies. These are usually also diesel generators of smaller capacity, installed below the EDGs and supporting a smaller part of the electrical system and therefore requiring a smaller part of the routes and loads to be available for re-usage after detection of degraded power supplies.

A few plant designs have on-site gas turbines with larger capacity to support a larger part of the plant electrical system. They therefore also require a larger part of the routes and sources to be available for re-usage after detection of degraded power supplies.

A few plant designs have dedicated off-site power sources that could be aligned to support only the nuclear power plant power requirements. These are however usually not absolute independent electrical power sources as they may be interconnected to the off-site grid at any time.

4.2.4. Enhanced robustness and resilience of the electrical power supply (3.3. 2)

There could be several means to enhance the robustness and resilience of the electrical power supply. This section presents a few identified by the survey.

Second turbine-generator train

Some respondents have dual turbine-generator trains, with each one supplying half of the plant's internal power system. With such a design, the point of common coupling for the safety trains will have an increased electrical separation, depending on how the off-site connection is configured. Usually, this means the point of common coupling is located in the off-site switchyard, rather than the generator busduct.

Second (standby) grid connection

All respondents have available at least a second grid connection that is more or less interconnected to the main grid connection. Some plants have a separate switchyard and/or voltage level at this connection point. It is common practice to use this as a standby connection, which is only used if the main connection is not available. However, it may be used during normal operation to power parts of the internal power system to reduce the likelihood of common cause failures. One respondent used both the main and standby connection in normal operation of the plant, each powering half of the plant electrical system. Another respondent reported using the standby grid connection to power the all-redundant trains of the emergency power system during normal operation, mainly to avoid disturbances from the main generator. Two other respondents mentioned using the standby grid connection during normal operation for a single train to reduce the risk of common cause failures, in particular if there is an increased risk of lightning strikes.

Transformer electromagnetic properties

Transformer designs have many variations and can affect the likelihood of certain failures. HV- to LV-side failures have occurred at some plants and led to fires, prompting the installation of shielding in the transformers. Such a design will not only reduce or eliminate the possibility of HV to LV bypass but also reduce the capacitive coupling, which will effectively reduce the transmission of fast transients. The winding configurations will also have an effect on transient propagation, whether helical, cross-over, sandwich, interleaved, etc. In transformers with multiple LV windings, each LV winding can display different transient behaviours, depending on its relative configuration.

A few respondents mentioned electrostatic shielding in particular to avoid HV to LV failures.

Dual power feed through diodes

In some plant designs, power supply to the reactor protection system is to some degree diversified by powering the system with both AC and DC through a diode. This does not eliminate the point of common coupling but provides for alternate power supply routes, which may be beneficial for some CCF scenarios.

Electrodynamic diversification

None of the respondents mentioned any particular measures to ensure different dynamic responses of redundant electrical trains. However, many mentioned that in most operational states there will be a different loading situation in different trains, contributing to a degree of diversification. No intentional measures seem to have been taken.

4.3. Questionnaire synthesis

This section provides a more detailed synthesis of the received answers to each question in the survey. The structure follows the questionnaire and the text in bold is from the questionnaire.

4.3.1. Power supplies

Which types of actuating (motive) and auxiliary (control) power supplies are used to support safety functions of the plant?

Please indicate the number of redundant trains for each. The same safety functions may be specified multiple times if it is necessary to illustrate the relationship between actuating and auxiliary power.

The responses to this question vary in level of detail. It can be concluded that the definition and breakdown of plant safety functions and mapping their power dependence is an onerous task that is not readily achievable. This illustrates the complexity of nuclear power plants' power dependency.

Nonetheless, it is clear that all safety functions depend on functional power supplies. Most require both motive and auxiliary power, while a few, primarily reactivity control, depend only on auxiliary power (or not at all in some cases, as it is likely that respondents interpreted differently whether there is a dependence when a "clean" loss of auxiliary power is required for actuation).

Regarding the types of motive power, the responses generally include two off-site sources, two to four emergency diesel generators as well as one ultimate diesel generator used as an alternative AC source. For auxiliary power, solid-state converters are usually used, both as rectifiers for battery charging and as inverters.

One respondent opted to do a higher-level breakdown of safety functions, which may be an approachable first step in considering safety function power dependence (reactivity control, emergency safety function actuation system, post-accident management, design extension condition management and severe accident management).

4.3.2. Electrical power supplies

The questions in this section intend to reflect electrical power supply characteristics. It may be advantageous to provide conceptual illustrations to the answers and could be attached.

4.3.2.1. Electrical power sources

How many off-site grid connections are available (and intended) to provide power to the safety functions?

Thirteen responses were received. It is clear from the responses that [10CFR50 Appendix A Criterion 17 - Electrical Power Systems] has been the governing criterion in the design of

off-site power supplies for nuclear power plants, such that most respondents reported two off-site grid connections, a main connection and a standby (or reserve) connection. A few plants adhere to the German KTA3701 requirements on Electrical Power Supplies for Nuclear Power Plants that require, in addition to the main and standby off-site connections, a third emergency off-site connection. Most respondents only use one of the grid connections during normal operation of the plant to support the internal electrical system, with one respondent using two grid connections during normal operation in a two plus two train arrangement.

Some plants energise the on-site power systems from the grid at a different voltage level from the generator feed-in point (e.g. the standby grid). With this configuration, the impact of a generator trip on the on-site power system is greatly reduced. This, however, usually incurs market arrangements to buy back power from the grid, which increases operating costs.

Some respondents operate nuclear power plants with dual turbine-generator sets per plant individually connected to the main off-site switchyard, providing two main grid connections and one standby connection to the off-site grid. One respondent has two transformers for the main grid connection.

The off-site switchyard configuration largely depends on the infrastructure at the site and no general conclusion on the independence of off-site connections can be drawn. Voltage levels for the off-site connections vary from 380 to 765 kV for the main off-site connection and from 70 to 345 kV for the standby off-site connection. Some respondents included the number of outgoing lines in the off-site switchyard in the description of off-site power sources. A few respondents dedicated power stations off-site (e.g. gas or hydro power plants) that can be aligned to supply only the nuclear power plant during emergencies.

How many main generators are used by the plant to power the safety functions?

Eleven responses were received. Most respondents have one generator per reactor, with some having two. In the latter case, each generator supplies two out of four electrical subdivisions in the plant.

Some respondents have house-load operation capability.

Some respondents have a generator circuit breaker and connect the station auxiliary transformers to the isolated phase busduct, whereas others have the unit breaker on the high-voltage side of the transformer.

Please elaborate how this affects the point of common coupling (as in 2.2.2).

Seven responses were received. Most respondents have the point of common coupling at the generator busbar during power operation, if the plant is equipped with a generator circuit breaker. Plants with no generator circuit breaker and plants with dual turbine-generator sets have the point of common coupling in the off-site switchyard. Plants using two off-site connections during normal operation have the point of common coupling at least one switchyard farther away. The point of common coupling for a majority of the plants is thus either:

- (a) The isolated phase busduct,
- (b) The off-site switchyard, or
- (c) At least one switchyard farther away.

How many emergency diesel generators are available at the plant in case no off-site connections are available?

Thirteen responses were received. They showed that one emergency diesel generator is generally provided per subdivision. A main difference between designs is whether there are two or four subdivisions for AC power, each with its own emergency diesel generator. There is no distinct trend separating older from newer reactor designs as both old and new designs feature either philosophy. However, some older plant designs with two safety AC subdivisions were initially modified to have four subdivisions and one respondent has six subdivisions, each with its own emergency diesel generator. It should be noted that the main rationale for these modifications has been to enhance the separation of subdivisions as original design requirements were less strict about separations in the full power system (i.e. source, routing and loads). New designs have stricter separation rules.

One respondent uses three safety subdivisions for AC power, with an emergency diesel generator for each train.

Two respondents, on the national and site levels, have different sets of emergency power sources in each train for internal events and external hazards, respectively. These plants therefore have twice the number of emergency diesel generators (i.e. 2x3 or 2x4).

Some respondents have also reported the availability of mobile generators that can be connected to the emergency power system. Some respondents share emergency power sources between units at a site.

Are there any, and if so how many, alternative AC generators at the plant?

Thirteen responses were received. Alternative AC (AAC) generators were originally discussed in US Regulatory Guide 1.155 on Station Blackout (SBO) as a means of coping. In an SBO scenario, all AC power in the plant, except AC power fed from inverters powered by batteries or AC power from an AAC, is assumed lost. The SBO considers the emergency diesel generators are also lost because they are automatically connected to the potentially faulty power system.

Some respondents with alternative power supplies to electrical, generally steam-driven pumps, do not implement an AAC. The plants with steam-driven pumps normally require some electrical power for control purposes. This is derived directly from the batteries with DC power for some designs while others use AC (UPS) power requiring a functional inverter connected to the batteries.

Some plants with steam-driven pumps, as well as most plants with no steam-driven pumps, provide some form of AAC. In some cases, large (≈ 30 MW) gas turbines adjacent to the site are used as AAC. However, this arrangement requires the normal electrical distribution system and sometimes parts of the off-site system to be available (e.g. off-site switchyard). Other plants use an additional diesel generator that is connected directly to the safety electrical distribution system, similarly to the emergency diesel generators. These could be of a smaller size as loss of coolant is normally not postulated simultaneously with a station blackout. Some sites have also implemented mobile generators of smaller size that may be connected to supply parts of the safety system with power. One respondent on the national level utilises a dedicated steam-driven generator in conjunction with a steam-driven pump.

Are there any, and if so how many, DC power sources at the plant?

Thirteen responses were received. All respondents said they use dedicated DC sources in each train for I&C voltages. Most batteries and solid-state devices for chargers and

inverters use flooded lead-acid cells. Some respondents use dedicated batteries for severe accident or station blackout scenarios.

What is the priority order of the above power sources in case of a safety function demand?

Twelve responses were received. Generally, the priority order can be summarised as below:

a) Main grid connection

b) House-load operation

If featured at the plant. Commonly applied in Europe, but not in US.

c) Standby grid connection

d) Emergency power system (EDG)

e) Alternative AC source or additional emergency power system

Two respondents on the national and site levels use the concept of an additional emergency power system, mainly to cope with severe external events. Most respondents without steam-driven systems include an alternative AC source, as summarised in 2.2.1.

f) DC sources, including UPS

g) Emergency grid connection

h) One respondent complying with the KTA3701 requirement has the possibility to connect to a third off-site grid connection.

i) Mobile diesel generators

Most respondents have implemented, or are planning to implement, mobile generators.

One respondent mentioned a rotational priority order of power sources so that when a loss is detected, sources are checked in sequence and a connection is made to the first available source that has appropriate voltage and frequency (main grid, EDG, standby grid, EDG, main grid, EDG, etc.).

All responses indicated that it is assumed that electrical anomalies can be reliably detected and selectively disconnected before underlying equipment is damaged.

Are there any other characteristics about the electrical power sources that -is considered to be of particular importance to assure electrical power supply robustness?

Thirteen responses were received. Some main points brought forward are listed below.

a) Diversity of emergency power sources cooling

A few responses mention the provision of diverse cooling for SBO or severe accident (SA) power sources and EDG, or within EDG, power sources, utilising air and water cooling to achieve diversification.

b) Diversity of batteries

One respondent on the national level mentioned the diversification of batteries on either the technical (lead-acid and nickel-cadmium) or manufacturer (lead-acid) level.

c) Mobile generators

Many respondents have, or are planning to implement, mobile generators. It is pointed out that the storage location as well as the location of the connection points need careful consideration of extreme external events to ensure possible usage after such an event.

d) House load

Some respondents have house-load capability. While this is advantageous in providing an additional level of defence-in-depth from a power source point of view, there is a risk of breakdown of the defence-in-depth due to severe electrical transients that may bypass protection. One respondent mentioned that some plants have modified the power supply to the safety busbars to be derived from the standby connection during normal operation to avoid the exposure of electrical safety buses to transients from the main generator.

e) Steam-driven pump electrical dependence

One respondent highlighted the need for electrical power to the steam-driven systems. In some designs, the electrical power source is derived directly from the batteries as DC while other designs require a functional inverter to provide AC power.

Are there any particular trade-offs in the power supply robustness concept where awareness is necessary?

Ten responses were received. It was highlighted that modifications to existing plants may be challenging due to space constraints. It was also recognised that similarity between trains is advantageous from a maintenance point of view while potentially being a source of common cause failure as plants are normally exposed to a point of common coupling. It was also pointed out that it can be difficult to detect failures in standby systems compared to live systems. Another concept identified was dual power feed of equipment through diodes.

4.3.2.2 Electrical Power Routing

How many redundant electrical trains does the plant have (AC and DC)?

Thirteen responses were received. From the responses it is obvious that earlier design concepts were based on dual redundancies with two safety trains for AC and sometimes also for DC but providing more (three or four) trains for control purposes. Modernised and newer designs usually have a fourfold redundancy throughout as well as providing a twofold redundancy for severe accident management.

Do the redundant trains share a common point of coupling during normal operation and if so where is it located (e.g. isolated phase busduct, site switchyard, one switchyard away)?

Thirteen responses were received. For most plants, the point of common coupling during power operation of the plant is either in the off-site switchyard or the generator busbar. One respondent on the national level mentioned some plants powering safety busbars from the standby connection during power operation to avoid main generator transients. The point of common coupling of the safety busbars is therefore the standby connection switchyard, but separated from the point of common coupling of the normal power supplies at the main off-site switchyard. One respondent at the site level reported they were investigating the

possibility of connecting at least one of four electrical subdivisions to the standby connection during power operation in order to enhance independence. One respondent on the national level highlighted that there is also a common grounding point at the plants, although no particular concern with this was highlighted.

Do the redundant trains share a common point of coupling during safety function actuation and, if so, where is it located (e.g. isolated phase busduct, site switchyard, one switchyard away)?

Thirteen responses were received. Most responses said that the power supply concept does not change at safety function actuation unless a degraded power supply is detected that causes disconnection of the main power supply. Some respondents, however, mentioned that on safety function actuation the priority is to isolate the safety electrical systems and source power from the emergency diesel generators, thus ensuring no point of common coupling remains between redundant trains.

Are the redundant electrical trains designed to be electrically identical or are there any design provisions to assure different electrical properties (e.g. impedances)?

Thirteen responses were received. Electrical trains normally are not designed to be dissimilar, but due to plant configuration, load requirements and operational conditions there are normally some variations between the electrical trains. Diversification is sometimes applied to power sources, either between defence-in-depth levels (e.g. EDG and AAC are diverse) or within defence-in-depth levels (e.g. different properties of EDGs, prominently cooling). Diversification in routing (e.g. converters/transformers) or loads (e.g. motors) is not mentioned in the responses, with the exception of one respondent that implemented a diversified plant section consisting of power supply, routing and loads but normally sharing a point of common coupling to the grid.

Are there any particular measures to mitigate undetected degraded power supply conditions?

Thirteen responses were received. All responses indicate that the electrical power supply protection systems require reliable detection of abnormal electrical conditions. Most responses also indicate that protection schemes are developed based on experience. Some respondents indicate motor-generator sets are used to ensure electrical isolation or note the possibility of using direct driven systems, for example cooling by using fire-water or other non-electric driven pumps, in case all electrical systems are lost.

What type of UPS is used to provide safety functions with AC power? STATIC/M-G set/other?

Twelve responses were received. A majority of the respondents are using static UPS systems. Two respondents on the national and site levels use motor-generator sets. Motor-generator sets are also more common in the control rod drive mechanism.

Are there any particular requirements or considerations on transformer design with regard to electrical transient propagation?

Thirteen responses were received. They highlighted active transformer protection and mentioned some design measures, such as winding configuration, grounding, shielding and design parameters. Some measures on transformer design that were mentioned include:

- transformer protection, such as loss of synchronism, grounding, overcurrent and differential;

- transformer coupling (Star/Delta) (in case of single phase to earth fault);
- short circuit impedance (to limit constraints on short circuit and slow transient);
- transmission ratio (to limit fast transient propagation constraints, i.e. lightning);
- grounded shield between the primary and secondary winding on main and standby transformers to avoid HV to LV failures (three respondents have implemented this, one however considered this to have more drawbacks after analysis);
- earthed screening is provided between the HV/LV windings on UPS system transformers and on I&C instrument transformers.

Are there any other characteristics about the electrical power routing that is considered to be of particular importance to assure electrical power supply robustness?

Twelve responses were received. Protection, separation, diversification, robustness and redundancy were mentioned as important. Some particular measures mentioned include:

- having surge arrestors on at least two different voltage levels in each of the two off-site connections;
- ensuring that the tripping of breakers in the connection to the off-site grid is done with two relay protection channels which both trip the two tripping coils of the breaker;
- having national regulatory guidance that requires total separation of severe accident management arrangements. In some cases, SA and DEC arrangements are possible to integrate as long as SA arrangements can be used if needed;
- separating cable differing functions on cable trays to ensure non-interference with I&C;
- generally running power cabling on upper cable route trays to avoid potential fire damage affecting I&C cabling;
- maintaining cable separation throughout the life of the plant by using dedicated software.

4.3.2.3 Electrical power sinks (loads)

Are there any intentional measures taken to ensure different dynamic response of redundant safety trains?

Thirteen responses were received. None of the respondents indicate any design measures to ensure different dynamic responses between redundant divisions. In many cases, however, due to plant configuration and operational state, there are some variations between the electrical trains.

4.3.2.4 Electrical isolation

Is there any power supply (source, route, load) that is, or could be, at all times isolated from the point of common coupling to prevent undetected conductive disturbances propagate? Please elaborate.

Thirteen responses were received. From the responses it is clear that all plants have power sources that are at all times isolated from the point of common coupling, but no power

supplies (i.e. source, route and load). A critical area mentioned is the necessary recharging of batteries in safety systems that require a continuous connection to a power source. A theoretical concept of alternating two battery halves (charging from source and discharging to loads) is mentioned. During outage, it may be possible to supply electrical subdivisions from different off-site power sources. One site respondent that implemented a diverse plant section, including full power supplies, could theoretically isolate this section during normal operation by using motor-generator sets. However, this has not been implemented.

What measures are relied upon to provide independence between the electrical trains?

Three responses were received. These mention physical separation, electrical isolation and functional independence.

Do these rely on active or passive isolation? E.g. inherent property such as a fuse or surge arrester or active detection required.

Thirteen responses were received. A combination of active and passive isolation is used at all plants in a similar setup.

- Passive isolation:
 - Surge arrestors on the main and standby connections.
 - Surge arrestors on the plant main busbars, i.e. secondary side of the station transformers and start transformer, on some plants.
 - Protective grounded conductors (top lines) above all air conductors on the main and standby connections on some plants.
 - Some plants using breakers to the off-site grid with a single actuator and a common mechanical connection to all three phases of the breaker.
 - The station transformers and the start transformer in some plants have a grounded shield between the primary and secondary winding. This shield can at a flashover in the transformer lead to an active rapid trip with disconnection via relay protection.
- Active isolation:
 - the tripping of breakers when an active fault has been detected by a relay protection;
 - current, voltage and frequency quality protection (high/low/ asymmetric);
 - unit breakers and generator breaker with pole discrepancy function.

Which characteristics of electrical power quality are they effective against? E.g. current, voltage, frequency, high/low/asymmetric.

Thirteen responses were received. Generally, it can be said that a number of protections must be co-ordinated in a systematic manner to protect against different phenomena. Some specifics include:

- Surge arrestors are effective against voltage and current by limiting the over voltage and leading the current to the grounding network.
- Protective grounded conductors (top lines) are effective against voltage and current by leading a lightning strike to the grounding network.

- The grounded shield between the primary and secondary winding in large transformers are effective against voltage by leading a flashover directly to the grounding network.
- A single actuator with a common mechanical connection to all three phases on a breaker is effective against asymmetry caused by a fault in a breaker by reducing the risk for an asymmetry condition since a mechanical fault is unlikely.
- A pole discrepancy function on a breaker is effective against asymmetry caused by a fault in a breaker by detecting the asymmetric conditions due to the fault and can then be disconnected by other breakers.
- Differential relay protections are effective against voltage, current, frequency, changes in impedance, asymmetry, etc. They disconnect the faulty part of the power system by tripping breakers.
- A power system stabiliser (PSS) on the main generator can be effective against power dynamic instability by stabilising power oscillations between the main generator and the off-site grid.

Are there any other characteristics about the electrical power sinks that is considered to be of particular importance to assure electrical power supply robustness?

Ten responses were received. Lessons learnt from open phase conditions and included in IAEA Safety report 91 are mentioned as well as water proofing of power supplies, as learnt from the Fukushima Daiichi Nuclear Power Plant accident, such as waterproofing of equipment areas. Load levels in the power system and transformer configuration may affect the capability to detect faults by impacting the dynamic responses. Low load levels make it more difficult to detect asymmetries. Common mode failures such as intake air filter blockages in EDG rooms may be mitigated by using bypass doors.

4.3.3. Remarks on the questionnaire or topic matter

Please provide additional remarks on what you have done, are doing or think would be good to do to assure robustness of electrical power systems at nuclear power plants. Maybe there is a particular design or operational feature you are aware of that has been used historically at your or other plants where information can be provided or should be looked for to provide insights on the subject matter.

Furthermore, feel free to comment on this questionnaire and especially the discussion in Section 2, whether it is useful and relevant or suggestions of how this work could proceed in order to better facilitate assurance of robust power supplies at nuclear power plants.

Four responses were received. It was mentioned that the focus should remain on the fundamental safety functions, reactivity control, emergency core cooling and containment integrity and ensure diversity and defence-in-depth to achieve nuclear safety. It was also pointed out that there are additional possibilities to operate systems without access to auxiliary power by manual measures. Further areas for investigation include off-site grid configurations, both alignment options to main and standby grids as well as physical connection options (e.g. lines or cables).

5. Further work

The report and survey identified a few implemented and conceptual design variations that may be beneficial for the robustness and resilience of the power supply of nuclear power plants. However, it would be of benefit to provide further detail of the experiences of various design variations. Sharing such experiences, possibly within the NEA WGELEC framework, should be encouraged.

The survey found that there is limited diversity between electrical trains, presumably in favour of maintainability. A further investigation of diversification principles between electrical trains, as well as the rationale for them and experiences thereof, could provide practical examples.

In earlier work [11], a systematic approach to categorising passive systems was proposed. As identified in this report, there are also differences between active systems and it may be possible to propose principles for the categorisation of active functions in a similar manner.

6. Conclusion

From the survey undertaken, the main observations affecting the robustness of nuclear power plant electrical systems are that:

- Redundant electrical systems are usually connected to a common point of coupling during all operational modes, unless abnormal electrical conditions can be detected.
- A separation must be ensured through electrical protection that is designed, implemented and functioning correctly.
- Harmful disturbances must generally be known or identified to enable design of an appropriate protection scheme.
- Defence-in-depth is applied for power sources, but only partially for routing or loads.
- Some plants have diverse systems independent of electrical power systems for motive power, but these usually require auxiliary electrical power to control and/or align the system.

The safe operation of nuclear plants depends on a reliable supply of power, particularly to enable residual heat removal and emergency core cooling. Many designs use electricity to supply this power to safety functions and the electrical system configuration is usually such that redundant functions share a point of common coupling in a number of operating modes, unless a fault is detected and isolated. Unanticipated failures and behaviours of the system remain a challenge and there have been events where redundant safety functions have been unable to fulfil their intended function due to disturbances at the point of common coupling.

By recognising that such unanticipated occurrences may affect multiple or all interconnected redundancies, it may be possible to identify design options that enhance the plant's robustness and resilience to such scenarios. Taking into account design practices applied elsewhere and experiences thereof can provide additional insights into how design variations may effectively be utilised to advance the robustness and resilience of the power supply to critical safety functions of new as well as existing nuclear power plant designs.

7. References

- [1] NEA (2015), “Robustness of Electrical Systems of Nuclear Power Plants in Light of the Fukushima Daiichi Accident (ROBELSYS): Workshop Proceedings, Paris, France, 1-4 April 2014”, NEA/CSNI/R(2015)4, OECD Publishing, Paris, www.oecd-nea.org/jcms/pl_19600/robustness-of-electrical-systems-of-npps-in-light-of-the-fukushima-daiichi-accident.
- [2] IAEA (2006), “Loss of 400 kV and subsequent failure to start Emergency Diesel Generators in sub A and sub B”, IRS-7788, IAEA, Vienna.
- [3] NRC (2012), “NRC Information Notice 2012-03: Design vulnerability in electric power system”, March 2012, NRC, Rockville, Maryland, <https://www.nrc.gov/docs/ML1204/ML120480170.pdf>.
- [4] NEA (2009), “Defence in Depth of Electrical Systems and Grid Interaction, Final DIDEFSYS Task Group Report”, NEA/CSNI/R(2009)10, OECD Publishing, Paris, www.oecd-nea.org/jcms/pl_18810.
- [5] NEA (2018), “Early identification of electrical failure mechanisms that affect safety at nuclear facilities, Technical Note” (internal document, not publicly available).
- [6] NEA (2019), “Comparison of methodologies for the simulation of electrical systems in nuclear power plants: Working Group on Electrical Power Systems Activity 3 Report”, NEA/CSNI/R(2018)10, OECD Publishing, Paris, www.oecd-nea.org/jcms/pl_19874.
- [7] ENSREG (2012), “Peer review report Stress tests performed on European nuclear power plants”, v12i-20120425, European Nuclear Safety Regulators Group, https://www.ensreg.eu/sites/default/files/EU%20Stress%20Test%20Peer%20Review%20Final%20Report_0.pdf.
- [8] Lundbäck, M. and M. Karlsson (2016), “Degraded Power Supplies”, International Conference on Nuclear Engineering, ICONE24-60255, V002T05A003, American Society of Mechanical Engineering (ASME), New York, <https://doi.org/10.1115/ICONE24-60255>.
- [9] IEEE (2006), “IEEE standard for Preferred Power Supply (PPS) for Nuclear Power Generating Stations (NPGS)”, Technical Report IEEE Std. 765-2006, Institute of Electrical and Electronics Engineers, New York, <https://doi.org/10.1109/IEEESTD.2006.248078>.
- [10] IEEE (1992), “IEEE Standard Criteria for the Independence of Class 1E equipment and Circuits”, Technical Report IEEE Std. 384-1992, Institute of Electrical and Electronics Engineers, New York, <https://doi.org/10.1109/IEEESTD.1992.114376>.
- [11] IAEA (1991), “Safety related terms for advanced nuclear plants”, IAEA-TECDOC-626, IAEA, Vienna, https://www-pub.iaea.org/MTCD/publications/PDF/te_626_web.pdf
- [12] G. Lindahl, G., E. Nyholm and T. Schütte (2019), “Survey of Robustness Measures in Electrical Designs in Nuclear Power Plants”, Report number 2018:519, Energiforsk, Stockholm, ISBN 978-91-7673-519-0, <https://energiforsk.se/en/news-archive/survey-of-robustness-measures-in-electrical-designs-in-nuclear-power-plants>.