

**ENVIRONMENT DIRECTORATE
JOINT MEETING OF THE CHEMICALS COMMITTEE AND
THE WORKING PARTY ON CHEMICALS, PESTICIDES AND BIOTECHNOLOGY**

Test Guidelines Programme

**DRAFT PROPOSAL FOR A NEW GUIDELINE: THE ISOLATED CHICKEN EYE (ICE) TEST
METHOD FOR IDENTIFYING OCULAR CORROSIVES AND SEVERE IRRITANTS**

21st Meeting of the Working Group of National Coordinators of the Test Guidelines Programme

31st March-2nd April 2009, OECD Headquarters, Paris, France

<p>Patric AMCOFF Tel: +33 (0)1 45 24 16 19; Fax: +33 (0)1 44 30 61 80; Email: patric.amcoff@oecd.org</p>
--

JT03259936

Document complet disponible sur OLIS dans son format d'origine
Complete document available on OLIS in its original format

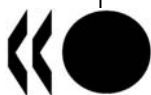

This document includes a proposal for a new Test Guideline on the “*Isolated Chicken Eye (ICE) Test Method for Identifying Ocular Corrosives and Severe Irritants*”, lead by the USA. The ICE test method is an *in vitro* test that can be used, under certain circumstances and with specific limitations, to classify substances as ocular corrosives and severe irritants as defined by the US EPA, the EU and the UN GHS. At this stage, the test methods cannot be used as full replacements for the rabbit *in vivo* test (Test Guideline 405). However, due to the low levels of false positives demonstrated by the validation study, substances that are tested positive can be classified as ocular corrosives or severe irritants without further testing in rabbits.

The draft ICE Test Guideline has been out twice for comments; first in mid-2008 when the comments received were subsequently addressed by an Expert Consultation Meeting held at US EPA in Washington DC on December 4-5, 2008. Secondly, a revised draft TG was circulated on 18 December 2008 with a deadline for comments of 6 February 2009. Since at the time of the submission of the draft TG to the WNT, the Expert Group was still working on developing a Proficiency Standard (PrS) for the ICE as agreed at the Expert Meeting, the draft PrS was not submitted to the WNT for comments until the 13 January 2009.

Comments were received from the Netherlands, France, Japan, US, Ireland, EC and ICAPO. The UK stated they had no further comments.

<i>ACTION REQUIRED:</i>	<i>The Working Group of National Coordinators of the Test Guidelines Programme is invited to approve the draft ICE Test Guideline, revised as appropriate.</i>
--------------------------------	---

OECD GUIDELINE FOR THE TESTING OF CHEMICALS

DRAFT PROPOSAL FOR A NEW GUIDELINE:

The Isolated Chicken Eye (ICE) Test Method for Identifying Ocular Corrosives and Severe Irritants

INTRODUCTION

1. The Isolated Chicken Eye (ICE) test method is an *in vitro* test method that can be used, under certain circumstances and with specific limitations, to classify substances as ocular corrosives and severe irritants as defined by the U.S. Environmental Protection Agency (EPA) (Category 1), the European Union (EU) (Category R41), and the United Nations (UN) Globally Harmonized System of Classification and Labelling of Chemicals (GHS) (Category 1)(1)(2)(3). For the purpose of this Test Guideline, severe irritants are defined as those that induce ocular lesions that persist in the rabbit for at least 21 days after administration. While it is not considered valid as a complete replacement for the *in vivo* rabbit eye test, the ICE is recommended for use as part of a tiered testing strategy for regulatory classification and labeling within a specific applicability domain (4)(5). Substances (including single chemicals and multi-component formulations)(6) that are positive in this assay can be classified as ocular corrosives or severe irritants without further testing in rabbits. A substance that tests negative would need to be tested in rabbits using a sequential testing strategy, as outlined in OECD Test Guideline 405 (7).

2. The purpose of this Test Guideline is to describe the procedures used to evaluate the potential ocular corrosivity or severe irritancy of a test substance as measured by its ability to induce toxicity in an enucleated chicken eye. Toxic effects to the cornea are measured by; (i), a qualitative assessment of opacity; (ii), a qualitative assessment of damage to epithelium based on application of fluorescein to the eye (fluorescein retention); and (iii), a quantitative measurement of increased thickness (swelling), and 4) a qualitative evaluation of macroscopic morphological damage to the surface. The corneal opacity, swelling, and damage assessments following exposure to a test substance are assessed individually and then combined to derive an Eye Irritancy Classification.

3. Ocular irritants that induce lesions that resolve in less than 21 days and non-irritants have also been tested using the ICE test method. However, the accuracy and reliability of the ICE test method for substances in these categories, as defined by the EPA (1), EU (2), and GHS (3), have not been formally evaluated.

4. Definitions are provided in Annex I.

INITIAL CONSIDERATIONS AND LIMITATIONS

5. This Test Guideline is based on the Interagency Coordinating Committee on the Validation of Alternative Methods (ICCVAM) ICE test method protocol (8), which was developed following an international validation study (4)(5)(9), with contributions from the European Centre for the Validation of Alternative Methods (ECVAM), the Japanese Center for the Validation of Alternative Methods (JaCVAM), and TNO Quality of Life Department of Toxicology and Applied Pharmacology. The protocol is based on information obtained from published protocols, as well as the current protocol used by TNO (10)(11)(12)(13)(14).

6. The identified limitations for this method are based upon the false positive rate for alcohols and the false negative rates for solids and surfactants (see paragraph 47) (4). When substances within these chemical and physical classes are excluded from the database, the accuracy of ICE across the EU, EPA, and GHS classification systems is substantially improved (4). Based on the purpose of this assay (*i.e.*, to identify ocular corrosives/severe irritants only), false negative rates are not critical since such substances would be subsequently tested in rabbits or with other adequately validated *in vitro* tests, depending on regulatory requirements, using a sequential testing strategy in a weight of evidence approach. Furthermore, the current validation database did not allow for an adequate evaluation of some chemical or product classes (*e.g.*, formulations). However, investigators could consider using this test method for testing all types of substances (including formulations), whereby a positive result could be accepted as indicative of an ocular corrosive or severe irritant response. However, positive results obtained with alcohols should be interpreted cautiously due to risk of over-prediction.

7. All procedures with chicken eyes should follow the test facility's applicable regulations and procedures for handling of human or animal-derived materials, which include, but are not limited to, tissues and tissue fluids. Universal laboratory precautions are recommended (15).

8. A limitation of the test method is that, although it takes into account some of the ocular effects evaluated in the rabbit ocular irritancy test method and to some degree their severity, it does not consider conjunctival and iridal injuries. Also, although the reversibility of corneal lesions cannot be evaluated *per se* in the ICE test method, it has been proposed, based on rabbit eye studies, that an assessment of the initial depth of corneal injury can be used to distinguish between irreversible and reversible effects (16). Finally, the ICE does not allow for an assessment of the potential for systemic toxicity associated with ocular exposure.

9. Efforts are ongoing to further characterize the usefulness and limitations of the ICE test method for identifying non-severe irritants and non-irritants (see also paragraph 48). This Test Guideline will be updated periodically as new information and data are considered. For example, histopathology may be potentially useful when a more complete characterization of corneal damage is needed. To evaluate this possibility, users are encouraged to preserve eyes and prepare histopathology specimens that can be used to develop a database and decision criteria that may further improve the accuracy of this test method. Users are also encouraged to provide specimens and/or data to validation organizations for a formal evaluation of possible future uses of the ICE test method, including for the identification of non-severe ocular irritants and non-irritants. The OECD is developing a Guidance Document on the use of *in vitro* ocular toxicity test methods, which will include detailed procedures on the collection of histopathology specimens and information on where to submit specimens and/or histopathology data.

10. For any laboratory initially establishing this assay, the proficiency standards provided in Annex II should be followed. A laboratory can use these standards to demonstrate their technical competence in performing the ICE test method prior to submitting ICE data for regulatory hazard classification purposes.

PRINCIPLE OF THE TEST

11. The ICE test method is an organotypic model that provides short-term maintenance of the chicken eye *in vitro*. In this test method, damage by the test substance is assessed by determination of corneal swelling, opacity, and fluorescein retention. While the latter two parameters involve a qualitative assessment, analysis of corneal swelling provides for a quantitative assessment. Each measurement is either converted into a quantitative score used to calculate an overall Irritation Index, or assigned a qualitative categorization that is used to assign an *in vitro* ocular corrosivity and severe irritancy classification. Either of these outcomes can then be used to predict the *in vivo* ocular corrosivity and severe irritation potential of a test substance (see Decision Criteria).

Source and Age of Chicken Eyes

12. Historically, eyes collected from chickens obtained from a slaughterhouse where they are killed for human consumption have been used for this assay, eliminating the need for laboratory animals. Only the eyes of healthy animals considered suitable for entry into the human food chain are used.

13. Although a controlled study to evaluate the optimum chicken age has not been conducted, the age and weight of the chickens used historically in this test method are that of spring chickens traditionally processed by a poultry slaughterhouse (*i.e.*, approximately 7 weeks old, 1.5 - 2.5 kg).

Collection and Transport of Eyes to the Laboratory

14. Heads should be removed immediately after sedation of the chickens, usually by electric shock, and incision of the neck for bleeding. A local source of chickens close to the laboratory should be located so that their heads can be transferred from the slaughterhouse to the laboratory quickly enough to minimize deterioration and/or bacterial contamination. The time interval between collection of the chicken heads and use of eyes in the ICE test method should be minimized (typically within two hours) and should be demonstrated to not compromise the assay results. These results are based on the selection criteria for the eyes, as well as the positive and negative control responses. All eyes used in the assay should be from the same group of eyes collected on a specific day.

15. Because eyes are dissected in the laboratory, the intact heads are transported from the slaughterhouse at ambient temperature in plastic boxes humidified with towels moistened with isotonic saline.

Selection Criteria for Eyes Used in the ICE

16. Eyes that have high baseline fluorescein staining (*i.e.*, > 0.5) or corneal opacity score (*i.e.*, > 0.5) after they are enucleated are rejected.

17. Each treatment group and concurrent positive control consists of at least three eyes. The negative control group or the solvent control (if using a solvent other than saline) consists of at least one eye.

PROCEDURE

Preparation of the Eyes

18. The eyelids are carefully excised, taking care not to damage the cornea. Corneal integrity is quickly assessed with a drop of 2% (w/v) sodium fluorescein applied to the corneal surface for a few seconds, and then rinsed with isotonic saline. Fluorescein-treated eyes are then examined with a slit-lamp microscope to ensure that the cornea is undamaged (*i.e.*, fluorescein retention and corneal opacity scores \leq 0.5).

19. If undamaged, the eye is further dissected from the skull, taking care not to damage the cornea. The eyeball is pulled from the orbit by holding the nictitating membrane firmly with surgical forceps, and the eye muscles are cut with a bent, blunt-tipped scissor. It is important to avoid causing corneal damage due to excessive pressure (*i.e.*, compression artifacts).

20. When the eye is removed from the orbit, a visible portion of the optic nerve should be left attached. Once removed from the orbit, the eye is placed on an absorbent pad and the nictitating membrane and other connective tissue are cut away.

21. The enucleated eye is mounted in a stainless steel clamp with the cornea positioned vertically. The clamp is then transferred to a chamber of the superfusion apparatus (16). The clamps should be positioned in the superfusion apparatus such that the entire cornea is supplied with the isotonic saline drip. The chambers of the superfusion apparatus should be temperature controlled at $32 \pm 1.5^\circ\text{C}$. Annex III provides a diagram of a typical superfusion apparatus and the eye clamps, which can be obtained commercially or constructed. The apparatus can be modified to meet the needs of an individual laboratory (*e.g.*, to accommodate a different number of eyes).

22. After being placed in the superfusion apparatus, the eyes are again examined with a slit-lamp microscope to ensure that they have not been damaged during the dissection procedure. Corneal thickness should also be measured at this time at the corneal apex using the depth measuring device on the slit-lamp microscope. Eyes with; (i), a fluorescein retention score of > 0.5 ; (ii) corneal opacity > 0.5 ; or, (iii), any additional signs of damage should be replaced. For eyes that are not rejected based on any of these criteria, individual eyes with a corneal thickness deviating more than 10% from the mean value for all eyes are to be rejected. Users should be aware that slit-lamp microscopes could yield different corneal thickness measurements if the slit-width setting is different. The slit-width should be set at 0.095 mm.

23. Once all eyes have been examined and approved, the eyes are incubated for approximately 45 to 60 minutes to equilibrate them to the test system prior to dosing. Following the equilibration period, a zero reference measurement is recorded for corneal thickness and opacity to serve as a baseline (*i.e.*, time = 0). The fluorescein score determined at dissection is used as the baseline measurement for that endpoint.

Application of the Test Substance

24. Immediately following the zero reference measurements, the eye (in its holder) is removed from the superfusion apparatus, placed in a horizontal position, and the test substance is applied to the cornea.

25. Liquid test substances are typically tested undiluted, but may be diluted if deemed necessary (*e.g.*, as part of the study design). The preferred solvent for diluted substances is physiological saline. However, alternative solvents may also be used under controlled conditions, but the appropriateness of solvents other than physiological saline must be demonstrated.

26. Liquid test substances are applied to the cornea such that the entire surface of the cornea is evenly covered with the test substance; the standard volume is 0.03 mL.

27. If possible, solid substances should be ground as finely as possible in a mortar and pestle, or comparable grinding tool. The powder is applied to the cornea such that the surface is uniformly covered with the test substance; the standard amount is 0.03 g.

28. The test substance (liquid or solid) is applied for 10 seconds and then rinsed from the eye with isotonic saline (approximately 20 mL) at ambient temperature. The eye (in its holder) is subsequently returned to the superfusion apparatus in the original upright position.

Control Substances

29. Concurrent negative or solvent/vehicle controls and positive controls should be included in each experiment.

30. When testing liquids at 100% or solids, physiological saline is used as the concurrent negative control in the ICE test method to detect non-specific changes in the test system, and to ensure that the assay conditions do not inappropriately result in an irritant response.

31. When testing diluted liquids, a concurrent solvent/vehicle control group is included in the test method to detect non-specific changes in the test system, and to ensure that the assay conditions do not inappropriately result in an irritant response. As stated in paragraph 25, only a solvent/vehicle that has been demonstrated to have no adverse effects on the test system can be used.

32. A known ocular irritant is included as a concurrent positive control in each experiment to verify that an appropriate response is induced. As the ICE assay is being used in this Test Guideline to identify corrosive or severe irritants, the positive control should be a reference substance that induces a severe response in this test method. However, to ensure that variability in the positive control response across time can be assessed, the magnitude of the severe response should not be excessive. Sufficient *in vitro* data for the positive control should be generated such that a statistically defined acceptable range for the positive control can be calculated. If adequate historical ICE test method data are not available for a particular positive control, studies may need to be conducted to provide this information.

33. Examples of positive controls for liquid test substances are 10% acetic acid or 5% benzalkonium chloride, while examples of positive controls for solid test substances are sodium hydroxide or imidazole.

34. Benchmark substances are useful for evaluating the ocular irritancy potential of unknown chemicals of a specific chemical or product class, or for evaluating the relative irritancy potential of an ocular irritant within a specific range of irritant responses.

Endpoints Measured

35. Treated corneas are evaluated pretreatment and starting at 30, 75, 120, 180, and 240 minutes (± 5 minutes) after the post-treatment rinse. These time points provide an adequate number of measurements over the four-hour treatment period, while leaving sufficient time between measurements for the requisite observations to be made for all eyes.

36. The endpoints evaluated are corneal opacity, swelling, fluorescein retention, and morphological effects (*e.g.*, pitting or loosening of the epithelium). All of the endpoints, with the exception of fluorescein retention (which is determined only at pretreatment and 30 minutes after test substance exposure) are determined at each of the above time points.

37. Photographs are advisable to document corneal opacity, fluorescein retention, morphological effects and, if conducted, histopathology

38. After the final examination at four hours, users are encouraged to preserve eyes in an appropriate fixative (*e.g.*, neutral buffered formalin) for possible histopathological examination.

39. Corneal swelling is determined from corneal thickness measurements made with an optical pachymeter on a slit-lamp microscope. It is expressed as a percentage and is calculated from corneal thickness measurements according to the following formula:

$$\left(\frac{\text{corneal thickness at time } t - \text{corneal thickness at time } = 0}{\text{corneal thickness at time } = 0} \right) \times 100$$

40. The mean percentage of corneal swelling for all test eyes is calculated for all observation time points. Based on the highest mean score for corneal swelling, as observed at any time point, an overall category score is then given for each test substance.

41. Corneal opacity is calculated by using the area of the cornea that is most densely opacified for scoring. The mean corneal opacity value for all test eyes is calculated for all observation time points. Based

on the highest mean score for corneal opacity, as observed at any time point, an overall category score is then given for each test substance (Table 1).

Table 1. Corneal opacity scores.

<u>Score</u>	<u>Observation</u>
<u>0</u>	No opacity
<u>0.5</u>	Very faint opacity
<u>1</u>	Scattered or diffuse areas; details of the iris are clearly visible
<u>2</u>	Easily discernible translucent area; details of the iris are slightly obscured
<u>3</u>	Severe corneal opacity; no specific details of the iris are visible; size of the pupil is barely discernible
<u>4</u>	Complete corneal opacity; iris invisible

42. The mean fluorescein retention value for all test eyes is calculated for the 30-minute observation time point only, which is used for the overall category score given for each test substance (Table 2).

Table 2. Fluorescein retention scores.

<u>Score</u>	<u>Observation</u>
<u>0</u>	No fluorescein retention
<u>0.5</u>	Very minor single cell staining
<u>1</u>	Single cell staining scattered throughout the treated area of the cornea
<u>2</u>	Focal or confluent dense single cell staining
<u>3</u>	Confluent large areas of the cornea retaining fluorescein

43. Morphological effects include “pitting” of corneal epithelial cells, “loosening” of epithelium, “roughening” of the corneal surface and “sticking” of the test substance to the cornea. These findings can vary in severity and may occur simultaneously. The classification of these findings is subjective according to the interpretation of the investigator.

DATA AND REPORTING

Data Evaluation

44. Results from corneal opacity, swelling, and fluorescein retention should be evaluated separately to generate an ICE class for each endpoint. The ICE classes for each endpoint are then combined to generate an Irritancy Classification for each test substance.

Decision Criteria

45. Once each endpoint has been evaluated, ICE classes can be assigned based on a predetermined range. Interpretation of corneal thickness (Table 3), opacity (Table 4), and fluorescein retention (Table 5) using four ICE classes is done according to the following scales:

Table 3. ICE classification criteria for corneal thickness.

Mean Corneal Swelling (%) [*]	ICE Class
0 to 5	I
>5 to 12	II
>12 to 18 (>75 min after treatment)	II
>12 to 18 (≤75 min after treatment)	III
>18 to 26	III
>26 to 32 (>75 min after treatment)	III
>26 to 32 (≤75 min after treatment)	IV
>32	IV

^{*}Corneal swelling scores only applicable if thickness is measured with a Haag-Streit BP900 slit-lamp microscope with depth-measuring device no. I and slit-width setting at 9½, equaling 0.095 mm. Users should be aware that slit-lamp microscopes could yield different corneal thickness measurements if the slit-width setting is different.

Table 4. ICE classification criteria for opacity.

Mean Maximum Opacity Score [*]	ICE Class
0.0-0.5	I
0.6-1.5	II
1.6-2.5	III
2.6-4.0	IV

^{*}See Table 1.

Table 5. ICE classification criteria for mean fluorescein retention.

Mean Fluorescein Retention Score at 30 minutes post-treatment [*]	ICE Class
0.0-0.5	I
0.6-1.5	II
1.6-2.5	III
2.6-3.0	IV

^{*}See Table 2.

46. The overall *in vitro* irritancy classification for a test substance is assessed by reading the irritancy classification that corresponds to the combination of categories obtained for corneal swelling, corneal opacity, and fluorescein retention and applying the scheme presented in Table 6.

Table 6. Overall *in vitro* irritancy classifications.

<u>Classification</u>	<u>Combinations of the 3 Endpoints</u>
Corrosive/Severe Irritant	3 x IV
	2 x IV, 1 x III
	2 x IV, 1 x II*
	2 x IV, 1 x I*
	Corneal opacity ≥ 3 at 30 min (in at least 2 eyes)
	Corneal opacity = 4 at any time point (in at least 2 eyes)
	Severe loosening of the epithelium (in at least 1 eye)

*Combinations less likely to occur.

47. As stated in paragraph 1, if the test substance is not identified as an ocular corrosive or severe irritant, additional testing should be conducted for classification and labeling purposes. The ICE test method has an overall accuracy of 83% (120/144) to 87% (134/154), a false positive rate of 6% (7/122) to 8% (9/116), and a false negative rate of 41% (13/32) to 50% (15/30) for the identification of ocular corrosives and severe irritants, when compared to *in vivo* rabbit eye test method data classified according to the EPA (1), EU (2), or GHS (3) classification systems. When substances within certain chemical (*i.e.*, alcohols and surfactants) and physical (*i.e.*, solids) classes are excluded from the database, the accuracy of ICE across the EU, EPA, and GHS classification systems ranges from 91% (75/82) to 92% (69/75), the false positive rates range from 5% (4/73) to 6% (4/70), and the false negative rates range from 29% (2/7) to 33% (3/9) (4).

48. Even if an ocular corrosive or severe irritant classification is not obtained for a test substance, ICE data can be useful in conjunction with test data from the *in vivo* rabbit eye test or from an adequately validated *in vitro* test to further evaluate the usefulness and limitations of the ICE test method for identifying non-severe irritants and non-irritants (a Guidance Document on the use of *in vitro* ocular toxicity test methods is under development).

Study Acceptance Criteria

49. A test is considered acceptable if the concurrent negative or vehicle/solvent controls and the concurrent positive controls give an Irritancy Classification that falls within nonirritant and severe irritant/corrosive classes, respectively.

Test Report

50. The test report should include the following information, if relevant to the conduct of the study:

Test and Control Substances;

- Chemical name(s) such as the structural name used by the Chemical Abstracts Service (CAS), followed by other names, if known;
- The CAS Registry Number (RN), if known;
- Purity and composition of the substance or preparation (in percentage(s) by weight), to the extent this information is available;
- Physicochemical properties such as physical state, volatility, pH, stability, chemical class, water solubility relevant to the conduct of the study;

- Treatment of the test/control substances prior to testing, if applicable (*e.g.*, warming, grinding);
- Stability, if known;

Information Concerning the Sponsor and the Test Facility;

- Name and address of the sponsor, test facility and study director;
- Identification on the source of the eyes (*e.g.*, the facility from which they were collected);
- Storage and transport conditions of eyes (*e.g.*, date and time of eye collection, time interval prior to initiating testing);
- If available, specific characteristics of the animals from which the eyes were collected (*e.g.*, age, sex, weight of the donor animal).

Justification of the Test Method and Protocol Used

Test Method Integrity;

- The procedure used to ensure the integrity (*i.e.*, accuracy and reliability) of the test method over time (*e.g.*, periodic testing of proficiency substances, use of historical negative and positive control data).

Criteria for an Acceptable Test;

- If applicable, acceptable concurrent benchmark control ranges based on historical data
- ##### Test Conditions;
- Description of test system used;
 - Slit-lamp microscope used (*e.g.*, model);
 - Instrument settings for the slit-lamp microscope used;
 - Information for the chicken eyes used, including statements regarding their quality;
 - Details of test procedure used;
 - Test substance concentration(s) used;
 - Description of any modifications of the test procedure;
 - Reference to historical data of the model (*e.g.*, negative and positive controls, proficiency substances, benchmark substances);
 - Description of evaluation criteria used.

Results;

- Description of other effects observed;
- If appropriate, photographs of the eye.

Discussion of the Results

Conclusion

A Quality Assurance Statement for Good Laboratory Practice (GLP)-Compliant Studies;

- This statement indicates all inspections made during the study, and the dates any results were reported to the Study Director. This statement also serves to confirm that the final report reflects the raw data.

If GLP-compliant studies are performed, then additional reporting requirements provided in the relevant guidelines (18) should be followed.

REFERENCES

- (1) U.S. EPA (1996). Label Review Manual: 2nd Edition. EPA737-B-96-001. Washington, DC: U.S. Environmental Protection Agency.
- (2) EU (2001). Commission Directive 2001/59/EC of 6 August 2001 adapting to technical progress for the 28th time Council Directive 67/548/EEC on the approximation of the laws, regulations and administrative provisions relating to the classification, packaging and labelling of dangerous substances. Official Journal of the European Communities L255:1-333.
- (3) United nations (UN) (2003). Globally Harmonized System of Classification and Labelling of Chemicals (GHS), Second revised edition, UN New York and Geneva, 2007. Available at: [http://www.unece.org/trans/danger/publi/ghs/ghs_rev02/02files_e.html]
- (4) ICCVAM (2007). Test Method Evaluation Report - *In Vitro Ocular Toxicity* Test Methods for Identifying Ocular Severe Irritants and Corrosives. Interagency Coordinating Committee on the Validation of Alternative Methods (ICCVAM) and the National Toxicology Program (NTP) Interagency Center for the Evaluation of Alternative Toxicological Methods (NICEATM). NIH Publication No.: 07-4517. Available: [http://iccvam.niehs.nih.gov/methods/ocutox/ivocutox/ocu_tmer.htm]
- (5) ESAC (2007). Statement on the conclusion of the ICCVAM retrospective study on organotypic *in vitro* assays as screening tests to identify potential ocular corrosives and severe eye irritants. Available: [<http://ecvam.jrc.it/index.htm>].
- (6) EC (2006). Regulation (EC) No 1907/2006 of the European Parliament and of the Council of 18 December 2006 concerning the Registration, Evaluation, Authorisation and Restriction of Chemicals (REACH), establishing a European Chemicals Agency, amending Directive 1999/45/EC and repealing Council Regulation (EEC) No 793/93 and Commission Regulation (EC) No 1488/94 as well as Council Directive 76/769/EEC and Commission Directives 91/155/EEC, 93/67/EEC, 93/105/EC and 2000/21/EC. Official Journal of the European Union L396/1 of 30.12.2006. OPOCE, Luxembourg.
- (7) OECD (2002). Test Guideline 405. OECD Guideline for Testing of Chemicals. Acute eye irritation/corrosion. Available: [http://www.oecd.org/document/40/0,2340,en_2649_34377_37051368_1_1_1_1,00.html]
- (8) ICCVAM (2007). ICCVAM Recommended ICE Test Method Protocol. In: ICCVAM Test Method Evaluation Report - *In Vitro* Ocular Toxicity Test Methods for Identifying Ocular Severe Irritants and Corrosives. Interagency Coordinating Committee on the Validation of Alternative Methods (ICCVAM) and the National Toxicology Program (NTP) Interagency Center for the Evaluation of Alternative Toxicological Methods (NICEATM). NIH Publication No.: 07-4517. Available: [http://iccvam.niehs.nih.gov/methods/ocutox/ivocutox/ocu_tmer.htm]
- (9) ICCVAM. (2006). Current Status of *In Vitro* Test Methods for Identifying Ocular Corrosives and Severe Irritants: Isolated Chicken Eye Test Method. NIH Publication No.: 06-4513. Research Triangle Park: National Toxicology Program. Available: [http://iccvam.niehs.nih.gov/methods/ocutox/ivocutox/ocu_brd_ice.htm]
- (10) Prinsen, M.K. and Koëter, B.W.M. (1993). Justification of the enucleated eye test with eyes of slaughterhouse animals as an alternative to the Draize eye irritation test with rabbits. *Fd. Chem. Toxicol.* 31:69-76.
- (11) INVITTOX (1994). Protocol 80: Chicken enucleated eye test (CEET). Available:

[<http://ecvam.jrc.it/index.htm>].

(12) Balls, M., Botham, P.A., Bruner, L.H. and Spielmann H. (1995). The EC/HO international validation study on alternatives to the Draize eye irritation test. *Toxicol. In Vitro* 9:871-929.

(13) Prinsen, M.K. (1996). The chicken enucleated eye test (CEET): A practical (pre)screen for the assessment of eye irritation/corrosion potential of test materials. *Food Chem. Toxicol.* 34:291-296.

(14) Chamberlain, M., Gad, S.C., Gautheron, P. and Prinsen, M.K. (1997). IRAG Working Group I: Organotypic models for the assessment/prediction of ocular irritation. *Food Chem. Toxicol.* 35:23-37.

(15) Siegel, J.D., Rhinehart, E., Jackson, M., Chiarello, L., and the Healthcare Infection Control Practices Advisory Committee (2007). Guideline for Isolation Precautions: Preventing Transmission of Infectious Agents in Healthcare Settings. Available: [<http://www.cdc.gov/ncidod/dhqp/pdf/isolation2007.pdf>].

(16) Maurer, J.K., Parker, R.D. and Jester J.V. (2002). Extent of corneal injury as the mechanistic basis for ocular irritation: key findings and recommendations for the development of alternative assays. *Reg. Tox. Pharmacol.* 36:106-117.

(17) Burton, A.B.G., M. York and R.S. Lawrence (1981) The in vitro assessment of severe irritants. *Fd. Cosmet.- Toxicol.*- 19, 471-480.

(18) OECD (1998). OECD Series on Principles of Good Laboratory Practice and Compliance Monitoring Number 1: OECD Principles on Good Laboratory Practice (as revised in 1997). ENV/MC/CHEM(98)17. Available: [http://www.oecd.org/document/63/0,3343,en_2649_34381_2346175_1_1_1_1,00.html]

(19) ICCVAM (2006) Background review document, Current Status of In Vitro Test Methods for Identifying Ocular Corrosives and Severe Irritants: Bovine Corneal Opacity and Permeability (BCOP) Test Method. Available: [http://iccvam.niehs.nih.gov/methods/ocutox/ivocutox/ocu_brd_bcop.htm]

(20) ICCVAM (2006) Background review document, Current Status of In Vitro Test Methods for Identifying Ocular Corrosives and Severe Irritants Isolated Chicken Eye (ICE) Test Method. Available: [http://iccvam.niehs.nih.gov/methods/ocutox/ivocutox/ocu_brd_bcop.htm]

ANNEX I

DEFINITIONS

Accuracy: The closeness of agreement between test method results and accepted reference values. It is a measure of test method performance and one aspect of “relevance.” The term is often used interchangeably with “concordance”, to mean the proportion of correct outcomes of a test method.

Benchmark substance: A substance used as a standard for comparison to a test substance. A benchmark substance should have the following properties; (i), a consistent and reliable source(s); (ii), structural and functional similarity to the class of substances being tested; (iii), known physical/chemical characteristics; (iv), supporting data on known effects; and (v), known potency in the range of the desired response

Cornea: The transparent part of the front of the eyeball that covers the iris and pupil and admits light to the interior.

Corneal opacity: Measurement of the extent of opaqueness of the cornea following exposure to a test substance. Increased corneal opacity is indicative of damage to the cornea.

Corneal swelling: An objective measurement in the ICE test of the extent of distention of the cornea following exposure to a test substance. It is expressed as a percentage and is calculated from baseline (pre-dose) corneal thickness measurements and the thickness recorded at regular intervals after exposure to the test material in the ICE test. The degree of corneal swelling is indicative of damage to the cornea.

EPA Category 1: Corrosive (irreversible destruction of ocular tissue) or corneal involvement or irritation persisting for more than 21 days (1).

EU Category R41: Production of tissue damage in the eye, or serious physical decay of vision, following application of a test substance to the anterior surface of the eye, which is not fully reversible within 21 days of application (2).

False negative rate: The proportion of all positive substances falsely identified by a test method as negative. It is one indicator of test method performance.

False positive rate: The proportion of all negative substances that are falsely identified by a test method as positive. It is one indicator of test method performance.

Fluorescein retention: A subjective measurement in the ICE test of the extent of fluorescein sodium that is retained by epithelial cells in the cornea following exposure to a test substance. The degree of fluorescein retention is indicative of damage to the corneal epithelium.

GHS (Globally Harmonized System of Classification and Labelling of Chemicals): A system proposing the classification of chemicals (substances and mixtures) according to standardized types and levels of physical, health and environmental hazards, and addressing corresponding communication elements, such as pictograms, signal words, hazard statements, precautionary statements and safety data sheets, so that to convey information on their adverse effects with a view to protect people (including employers, workers, transporters, consumers and emergency responders) and the environment (3).

GHS Category 1: Production of tissue damage in the eye, or serious physical decay of vision, following application of a test substance to the anterior surface of the eye, which is not fully reversible within 21 days of application (3).

Good Laboratory Practices (GLP): Regulations promulgated by a number of countries and national regulatory bodies that describe record keeping and quality assurance procedures for laboratory records that will be the basis for data submissions to regulatory authorities. Also the subject of the OECD Series on “Principles of Good Laboratory Practice and Compliance Monitoring” (18).

Hazard: Inherent property of an agent or situation having the potential to cause adverse effects when an organism, system or (sub) population is exposed to that agent.

Negative control: An untreated replicate containing all components of a test system. This sample is processed with test substance-treated samples and other control samples to determine whether the solvent interacts with the test system.

Non-irritant: Substances that are not classified as EPA Category I, II, or III; EU Category R41 or R36; or GHS Category 1, 2A, or 2B ocular irritants (1)(2)(3).

Ocular corrosive: (a) A substance that causes irreversible tissue damage to the eye. (b) Substances that are classified as GHS Category 1, EPA Category I, or EU Category R41 ocular irritants (1)(2)(3).

Ocular irritant: (a) A substance that produces a reversible change in the eye following application to the anterior surface of the eye; (b) Substances that are classified as EPA Category II or III; EU Category R36; or GHS Category 2A, or 2B ocular irritants (1)(2)(3).

Ocular severe irritant: (a) A substance that causes tissue damage in the eye following application to the anterior surface of the eye that is not reversible within 21 days of application or causes serious physical decay of vision. (b) Substances that are classified as GHS Category 1, EPA Category I, or EU Category R41 ocular irritants (1)(2)(3).

Positive control: A replicate containing all components of a test system and treated with a substance known to induce a positive response. To ensure that variability in the positive control response across time can be assessed, the magnitude of the severe response should not be excessive.

Proficiency Standards: Prior to routine use of a test method that adheres to an OECD Test Guideline, laboratories can demonstrate technical proficiency by correctly identifying the hazard classification of a set of reference substances ("proficiency substances"). A laboratory can use these standards to demonstrate their technical competence in performing a test method prior to submitting data for regulatory hazard classification purposes.

Reliability: Measures of the extent that a test method can be performed reproducibly within and between laboratories over time, when performed using the same protocol. It is assessed by calculating intra- and inter-laboratory reproducibility and intra-laboratory repeatability.

Slit-lamp microscope: An instrument used to directly examine the eye under the magnification of a binocular microscope by creating a stereoscopic, erect image. In the ICE test method, this instrument is used to view the anterior structures of the chicken eye as well as to objectively measure corneal thickness with a depth-measuring device attachment.

Solvent/vehicle control: An untreated sample containing all components of a test system, including the solvent or vehicle that is processed with the test substance-treated and other control samples to establish the baseline response for the samples treated with the test substance dissolved in the same solvent or vehicle. When tested with a concurrent negative control, this sample also demonstrates whether the solvent or vehicle interacts with the test system.

Tiered testing: A stepwise testing strategy where all existing information on a test substance is reviewed, in a specified order, using a weight of evidence process at each tier to determine if sufficient information is available for a hazard classification decision, prior to progression to the next tier. If the irritancy potential of a test substance can be assigned based on the existing information, no additional testing is required. If the irritancy potential of a test substance cannot be assigned based on the existing information, a step-wise sequential animal testing procedure is performed until an unequivocal classification can be made.

Validated test method: A test method for which validation studies have been completed to determine the relevance (including accuracy) and reliability for a specific purpose. It is important to note that a validated test method may not have sufficient performance in terms of accuracy and reliability to be found acceptable for the proposed purpose.

Weight-of-evidence: The process of considering the strengths and weaknesses of various pieces of information in reaching and supporting a conclusion concerning the hazard potential of a substance.

ANNEX II**PROFICIENCY STANDARDS FOR THE ICE TEST METHOD**

Prior to routine use of a test method that adheres to this Test Guideline, laboratories may wish to demonstrate technical proficiency by correctly identifying the ocular corrosivity classification of the 10 substances recommended in Table 1. These substances were selected to represent the range of responses for local eye irritation/corrosion, which is based on results in the *in vivo* rabbit eye test (TG 405) (*i.e.*, Categories 1, 2A, 2B, or Not Labeled according to the UN GHS)(3)(7). However, considering the validated usefulness of these assays (*i.e.*, to identify ocular corrosives/severe irritants only), there are only two test outcomes for classification purposes (corrosive/severe irritant or non-corrosive/non-severe irritant) to demonstrate proficiency. Other selection criteria were that substances are commercially available, there are high quality *in vivo* reference data available, and there are high quality data from the two *in vitro* methods for which test guidelines are being developed. For this reason, irritant substances were selected from the ICCVAM recommended list of 122 reference substances for the validation of *in vitro* ocular toxicity test methods (see Appendix H, ICCVAM Recommended Reference Substances List)(4). Reference data are available in the ICCVAM Background Review Documents for BCOP and ICE (19)(20).

Table 1. Recommended substances for demonstrating technical proficiency with BCOP or ICE.

Chemical	CASRN	Chemical Class¹	Physical Form	<i>In Vivo</i> Classification²	<i>In Vitro</i> Classification³
Benzalkonium chloride (5%)	8001-54-5	Onium compound	Liquid	Category 1	Corrosive/ Severe Irritant
Chlorhexidine	55-56-1	Amine, Amidine	Solid	Category 1	Corrosive/ Severe Irritant
Dibenzoyl-L-tartaric acid	2743-38-6	Carboxylic acid, Ester	Solid	Category 1	Corrosive/ Severe Irritant
Imidazole	288-32-4	Heterocyclic	Solid	Category 1	Corrosive/ Severe Irritant
Trichloroacetic acid (30%)	76-03-9	Carboxylic Acid	Liquid	Category 1	Corrosive/ Severe Irritant
2,6-Dichlorobenzoyl chloride	4659-45-4	Acyl halide	Liquid	Category 2A	Noncorrosive/ Nonsevere irritant
Ethyl-2-methylacetoacetate	609-14-3	Ketone, Ester	Liquid	Category 2B	Noncorrosive/ Nonsevere irritant
Ammonium nitrate	6484-52-2	Inorganic salt	Solid	Category 2B	Noncorrosive/ Nonsevere irritant
Glycerol	56-81-5	Alcohol	Liquid	Not Labeled	Noncorrosive/ Nonsevere irritant
n-Hexane	110-54-3	Hydrocarbon (acyclic)	Liquid	Not Labeled	Noncorrosive/ Nonsevere irritant

Abbreviations: CASRN = Chemical Abstracts Service Registry Number

¹Chemical classes were assigned to each test substance using a standard classification scheme, based on the National Library of Medicine Medical Subject Headings (MeSH) classification system (available at <http://www.nlm.nih.gov/mesh>)

²Based on results from the *in vivo* rabbit eye test (OECD TG 405) and using the UN GHS (3)(7).

³Based on results in BCOP and ICE.

ANNEX III

DIAGRAMS OF THE ICE SUPERFUSION APPARATUS AND EYE CLAMPS

(See Burton et al. (17) for additional generic descriptions of the superfusion apparatus and eye clamp)

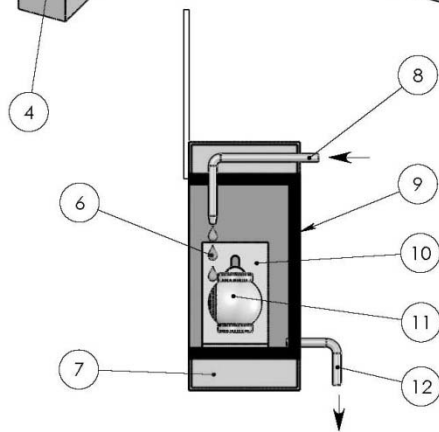
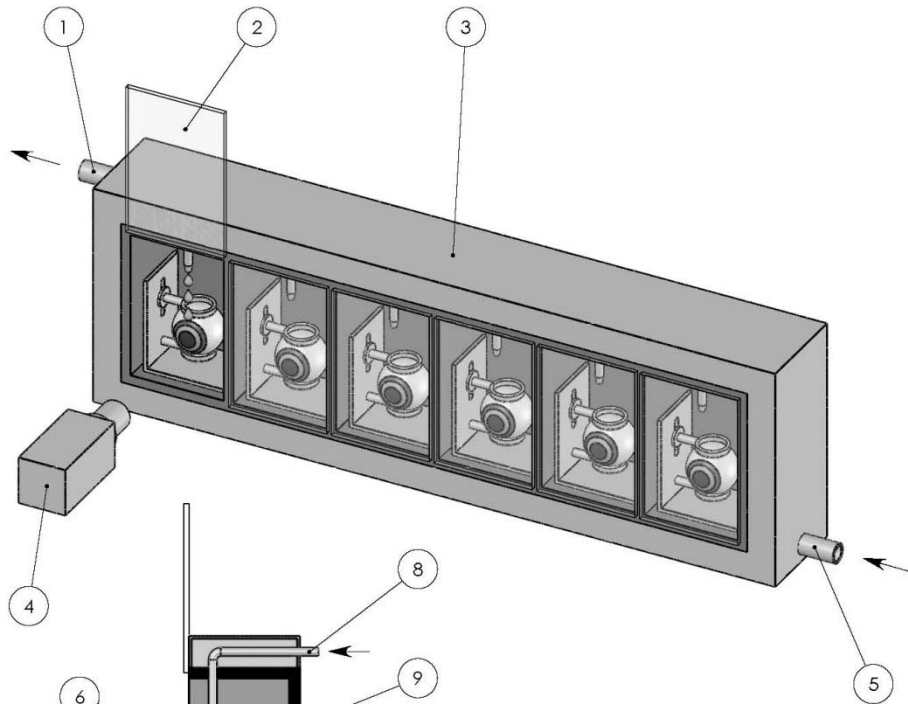

CROSS SECTION COMPARTMENT

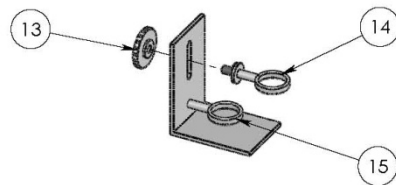

EYE HOLDER

ITEM NO.	DESCRIPTION
1	OUTLET WARM WATER
2	SLIDING DOOR
3	SUPERFUSION APPARATUS
4	OPTICAL MEASURING INSTRUMENT
5	INLET WARM WATER
6	SALINE SOLUTION
7	WARM WATER
8	INLET SALINE SOLUTION
9	COMPARTMENT
10	EYE HOLDER
11	CHICKEN EYE
12	OUTLET SALINE SOLUTION
13	SETScrew
14	ADJUSTABLE UPPER ARM
15	FIXED LOWER ARM