

Unclassified

ENV/EPOC/WPRPW(2016)2/FINAL

Organisation de Coopération et de Développement Économiques
Organisation for Economic Co-operation and Development

09-Nov-2017

English - Or. English

ENVIRONMENT DIRECTORATE
ENVIRONMENT POLICY COMMITTEE

Working Party on Resource Productivity and Waste

MAPPING SUPPORT FOR PRIMARY AND SECONDARY METAL PRODUCTION

Contact persons: Peter BÖRKEY, Principal Administrator, Environment Directorate;
Peter.BORKEY@oecd.org; +33-1 45 24 13 85. Andrew MCCARTHY, Consultant, Environment
Directorate; Andrew.MCCARTHY@oecd.org; +33-1 45 24 98 63

JT03422608

This document, as well as any data and map included herein, are without prejudice to the status of or sovereignty over any territory, to the delimitation of international frontiers and boundaries and to the name of any territory, city or area.

ENV/EPOC/WPRPW(2016)2/FINAL
Unclassified

English - Or. English

TABLE OF CONTENTS

LIST OF ACRONYMS5

EXECUTIVE SUMMARY6

 Background6

 Typology of support measures relevant for primary and secondary metals6

 Support for primary metal production7

 Support for secondary metal production8

 Effects of support8

 Discussion and recommendations9

1. INTRODUCTION11

 1.1 Background11

 1.2 Outline of this report13

 1.3 Overview of the metals industry14

2. TYPOLOGY OF SUPPORT MEASURES RELEVANT FOR METALS24

 2.1 Existing support typologies24

 2.2 A support typology for primary and secondary metals25

 2.3 Discussion of selected aspects of the typology27

3. WHAT IS KNOWN: SUPPORT FOR PRIMARY METAL PRODUCTION30

 3.1 Introduction30

 3.2 Literature review of support for primary metal production30

 3.3 Common forms of support for primary metal production31

4. WHAT IS KNOWN: SUPPORT FOR SECONDARY METAL PRODUCTION42

 4.1 Introduction42

 4.2 Literature review of support for secondary metal production42

 4.3 Common forms of support for secondary metal production43

5. TRADE RESTRICTIONS ON MINERAL ORES, SCRAP, AND METALS50

 5.1 Introduction50

 5.2 Trade in mineral ores, scrap, and metals: some stylistic facts50

 5.3 Export restrictions55

6. POSSIBLE EFFECTS OF SUPPORT FOR METAL PRODUCTION60

 6.1 Introduction60

 6.2 Impact of support at the firm level61

 6.3 Impact of support on aggregate primary and secondary market share63

 6.4 From market share to life-cycle environmental impacts66

7. SUPPORT FOR METALS PRODUCTION: TAKING STOCK AND LOOKING FORWARD69

 7.1 The contribution of this report69

7.2	The way forward: quantifying the value of support for the metals sector	70
ANNEX 1. SUPPORT DEFINITIONS FROM INTERGOVERNMENTAL ORGANISATIONS		
	World Trade Organization	80
	The World Bank.....	81
	The Global Subsidies Initiative (GSI).....	81
	The International Monetary Fund (IMF)	81
ANNEX 2. EXISTING ASSESSMENTS OF SUPPORT FOR PRIMARY AND SECONDARY METAL PRODUCTION		
	Primary support.....	83
	Secondary support.....	85
ANNEX 3. CONSIDERATIONS FOR FUTURE WORK: QUANTIFICATION OF SUPPORT FOR THE METALS SECTOR		
	Quantifying support: lessons from past experience	87
	Quantifying support: considerations for the metals sector.....	89
	Quantifying the value of support in the metals sector: what is feasible?.....	91

Tables

Table 1.	Geographic distribution of finished primary steel, aluminium, and copper production	17
Table 2.	Primary and secondary material support typology with selected examples	26
Table 3.	State equity participation in mining projects in mining jurisdictions	33
Table 4.	Share of global metal production from 100% state owned enterprises (SOEs) by country ..	34
Table 5.	Summary of labour, capital, and mineral resource tax rates for various jurisdictions.....	37
Table 6.	Relative energy and carbon intensity of primary and secondary metal production.....	38
Table 7.	Global metals trade data for 2015.....	51
Table 8.	Export restrictions by measure in 2014.....	55
Table 9.	Export restrictions by metal in 2014.....	55
Table 10.	Common modes of support by country type.....	70

Figures

Figure 1.	The primary and secondary metal supply chains.....	14
Figure 2.	Example of the primary production process for copper in sulphide ore.....	15
Figure 3.	Example of the secondary sorting process for household appliances.....	16
Figure 4.	Geographic distribution of iron, aluminium, and copper production	17
Figure 5.	Geographic distribution of finished primary steel, aluminium, and copper production	18
Figure 6.	End of life recycling rate for various metals	19
Figure 7.	Geographic distribution of finished secondary steel, aluminium, and copper production	20
Figure 8.	Primary - secondary market share for finished steel, aluminium, and copper.....	21
Figure 9.	Finished primary and secondary steel production in large producer countries	22
Figure 10.	Finished primary and secondary aluminium production in large producer countries	22
Figure 11.	Evolution of primary and secondary market shares for steel, aluminium, and copper.....	23
Figure 12.	Total tax (corporate income tax + royalty payments) by mining jurisdiction	40
Figure 13.	Green bond issuance by source between 2007 and 2015	44
Figure 14.	Landfill tax rates – euros per tonne – in OECD countries in 2013.....	47
Figure 15.	The evolution of upstream primary and secondary material exports by weight.....	52

Figure 16.	The evolution of upstream primary and secondary material exports by nominal value.	52
Figure 17.	Top five exporters of ore, scrap, and finished metals.....	53
Figure 18.	Top five importers of primary ore and scrap.....	54
Figure 19.	Year of introduction of export restrictions present in 2012.....	56
Figure 20.	The economic and environmental impacts of support.....	64
Figure 21.	Life-cycle externalities associated with metal production.....	67

Boxes

Box 1.	Support estimates at the OECD.....	24
Box 2.	International impacts of domestic support	66
Box 3.	Definition of a subsidy in the WTO Agreement on Subsidies and Countervailing Measures	80

LIST OF ACRONYMS

ABREE	Australian Bureau of Resources and Energy Economics
APEC	Asia-Pacific Economic Cooperation
BIR	Bureau of International Recycling
BOF	Blast Oxygen Furnace
CIT	Corporate Income Tax
CSE	Consumer Support Estimate
EAF	Electric Arc Furnace
EC	European Commission
EIB	European Investment Bank
EOL	End of Life
EOL-RR	End of Life Recycling Rate
EPR	Extended Producer Responsibility
EU	European Union
GCC	Gulf Cooperation Council
GSI	Global Subsidies Initiative
GSSE	General Services Support Estimate
IISD	International Institute for Sustainable Development
IMF	International Monetary Fund
IWSA	International Solid Waste Association
LME	London Metal Exchange
MSW	Municipal Solid Waste
NPV	Net Present Value
OECD	Organisation for Economic Cooperation and Development
PSE	Producer Support Estimate
RC	Recycled Content
REE	Rare Earth Element
SOE	State Owned Enterprise
UNEP	United Nations Environment Program
USGS	United States Geological Survey
VAT	Value Added Tax
WTO	World Trade Organization

EXECUTIVE SUMMARY

Background

1. Metallic mineral ores constitute one fifth of global raw-material consumption. They are the main traditional source of metal used by society, and currently account for around 80% of the production of the most widely used metals – steel, aluminium, and copper. Virgin mineral resources are even more important for precious, technology, and rare-earth metals, often representing more than 95% of total metal production.

2. Ongoing extraction of metals from virgin mineral resources, and their subsequent use in the production of various goods, has led to a steadily growing above ground stock of metals. Anthropogenic metal resources are heavily concentrated in urban areas, either in the form of long-lived capital goods such as buildings, infrastructure, and machinery, short-lived consumer goods such as personal electronics, or end-of-life goods that have been disposed of in landfills. The flow of scrap metal emerging from in-use stocks is the key source of feedstock for secondary metal production, which today accounts for no more than 20% of global metal supply.

3. The primary and secondary metal production processes produce finished metal products that are perfect, or near perfect substitutes for each other. Competition between firms operating in each sector takes place mostly at the smelting or refining stage of the metals value chain. The share of secondary production in total finished metal output has generally increased over time, although the share of secondary steel and aluminium production has declined significantly since 2000. This pattern, combined with concerns about domestic supply risks, the negative environmental consequences of primary metal extraction and processing, and the management of steadily growing waste streams have led to increased interest in how to move towards an economy in which waste materials are captured and fed back into the economy.

4. In this context, the question arises as to what extent support for primary and secondary material production is consistent with resource efficiency and other environmental objectives. Recent OECD work on support for fossil fuels highlighted the widespread existence of various policies and regulations which probably serve to encourage additional production or consumption of fossil fuels. Relatively little such systematic work has been undertaken for the metals sector. The handful of existing studies find that support for the metals sector, (i) can be significant, extending into the billions of dollars in some countries, and (ii) typically accrues disproportionately, in both absolute and per-unit of output terms, to the primary sector.

Typology of support measures relevant for primary and secondary metals

5. A typology has been developed to document and classify various forms of support for the metals industry. It draws heavily on existing OECD work on support; individual measures are primarily classified along two main dimensions: the transfer mechanism, and the formal incidence (whether the measure relates to output returns, enterprise income, input costs, or consumption). Support is also classified according to whether it is available initially to consumers or producers, and in the latter case, where in the metal value chain it is initially incident.

6. In addition, the typology includes several additional fields which reflect the particular characteristics of support available in the metals sector. For example, support for primary and

secondary metal production varies according to which level of government it is provided by. Primary support tends to originate at the national level, whereas many forms of secondary support are sourced from provincial or municipal levels of government. The typology allows this distinction to be captured. Similarly, many support measures in the metals sector are horizontal in nature – their availability is not restricted to either primary or secondary producers. Capturing this is potentially important because industry lobby groups frequently argue that a given policy does not represent preferential support if it is potentially available across different sectors or industries of the economy.

7. Although the emphasis in this report is on mapping out common forms of support, it is envisaged that the typology will provide a framework for any future quantitative assessments of primary and secondary metal support. In practice, there exists a trade-off between documenting a broad range of support measures and being able to quantify a significant proportion of them. Many historic assessments of support for various sectors restrict their focus to direct budgetary transfers and foregone tax revenues; the data and modelling requirements for quantifying other forms of support have been considered too great. This report considers a broad number of policies, some of which may be beyond certain traditional conceptions of support.

Support for primary metal production

8. *Tax related support* measures that increase firm income or reduce the cost of capital, energy, or mineral resources are very common in the primary sector. Mining and mineral processing firms benefit from targeted reductions in the corporate income tax rate and tax holidays in several important mining jurisdictions. Extended loss carry-forward provisions are common and allow mining firms to use historic financial losses resulting from exploration, feasibility, and development work to offset taxable income in the current period. Accelerated-depreciation provisions (ADPs) allow the value of capital assets to be written off relatively rapidly, which, in turn, improves project profitability by reducing taxable income early in a project's life. They are particularly important in the primary metals sector given the capital intensity of the typical business model. Finally, excise tax rate reductions or exemptions for fuel and electricity used to extract or process mineral ores are available in a number of countries.

9. In many cases, tax-related support measures are non-targeted. They are theoretically available for material capture and recycling firms, but often accrue mostly to primary producers due to the character of that business model. For example, extended tax loss carry-forward allowances preferentially benefit mining firms because of the lengthy character of the pre-production period. In a similar way, accelerated-depreciation provisions and energy excise tax rate reductions are probably of greater value to primary metals firms because of the relative capital and energy intensity of mineral ore beneficiation and processing.

10. *The public provision of investment finance* on concessionary terms is also a common form of support within the primary metal sector. Publicly capitalised development banks and export-credit agencies frequently invest large sums in upstream mining projects, while partially or fully state-owned mining companies may not be required to earn the same rates of return on capital as their private counterparts.

11. *Export restrictions* on mineral ores, concentrates, and metal scrap exist in around 30 countries. These confer support for domestic downstream processing firms in both the primary and secondary sectors if increased supply places downward pressure on feedstock prices. When applied by countries representing a large share of international metal flows, trade restrictions can also affect international commodity prices and therefore competition between primary and secondary metals firms in other jurisdictions. Major primary metal-producing countries currently applying significant export restrictions include Brazil, China, and Indonesia. Secondary export restrictions are not generally applied by major scrap exporters although trade regulations relating to hazardous materials may disrupt cross border flows of electronic waste and other metal containing products.

Support for secondary metal production

12. *The public provision of investment finance* on concessionary terms is common in the secondary sector. Public investment finance is channelled through a variety of national and multi-lateral lenders in order to support environmental objectives. Within the EU, the European Investment Bank operates two large funds that both target projects that support objectives related to the circular economy and material efficiency. Similarly earmarked public funds are also available at the national and sub-national levels in a number of countries. The pool of potential investment finance available for recycling projects has increased in recent years with the rapid expansion of green bonds.¹

13. Many other support measures available to the secondary metals sector represent *induced transfers*, whereby a particular regulation results in a transfer from agents elsewhere in the economy to recipient firms. Landfill taxes and bans, the public provision of separated recycling collection, and product take-back legislation all introduce additional costs for waste-disposal organisations, local governments, firms, and ultimately households and consumers. For material sorting and recycling firms, these measures increase the quality and supply of scrap feedstock, which can translate into reduced production costs. Quantifying the monetary value of these measures is difficult, and presents a key barrier to comparing the magnitude of primary and secondary support. In particular, there is often a difference between the net cost of the measure for governments, and the net benefits of the measure for recipients. In the case of landfill taxes, the net cost for governments is actually negative (taxes generate revenues) while the net benefits conferred to recycling firms is difficult to quantify; it depends on how the tax translates into feedstock prices.

14. Many forms of secondary support are relevant mostly for the municipal solid waste (MSW) stream. Public awareness campaigns emphasise the importance of sorting household waste. Many extended producer responsibility² (EPR) schemes target consumer goods traditionally processed via the municipal waste system, and the provision of separated collection of recyclables is only available for household and small business waste. These policies have clear relevance for materials such as paper and plastic, for which MSW represents a volumetrically large share of total secondary supply. Their importance is less clear for metals, which comprise only around 5% of MSW by weight in most industrialised countries. The Construction and Demolition (C&D) waste stream contains a similar proportion of metal, but tends to be around twice the size in terms of total waste volumes. Commercial and industrial (C&I) waste flows are slightly larger than those for MSW, but typically include a metal content of around 20%.

15. Support measures in the secondary sector appear to address market failures to a greater extent than those in the primary sector (which often appear to be designed to attract investment). They also tend to place less of a burden on public budgets; landfill taxes generate revenues, EPR schemes and mandated recycled content labelling are budget neutral, and the public provision of separated recyclables collection is usually at least partially covered by the sale of recyclables and receipt of municipal waste charges.

Effects of support

16. The immediate impact of a support measure is to stimulate additional domestic production, either in the short run as marginal units become economically viable, or in the long run as domestic investment decisions are affected. Metal value chains span international borders, and increased production resulting from support in one jurisdiction can translate into increased supply, which places downward pressure on world prices. The international transmission of support is most likely when it

¹ The Climate Bonds Initiative defines a Green Bond as a bond where “the proceeds are allocated to environmental projects.

² The OECD defines EPR as “an environmental policy approach in which a producer’s responsibility for a product is extended to the post-consumer stage of a product’s life cycle.

is provided in countries representing a large share of global production. High-cost production, both primary and secondary, situated elsewhere becomes increasingly marginal and may be discontinued, either through production cut-backs or firm exit. In this way, support modifies the primary and secondary production shares both domestically and globally.

17. Empirical data indicate that secondary re-melters and smelters are less responsive to support than their primary counterparts. In practice, this means that secondary producers are less able to take advantage of lower input prices or higher output prices. That is important in the context of this report because it implies that a targeted primary or secondary support measure may not translate into additional production in the same way. In particular, support for the primary sector may have a disproportionately large impact on the primary–secondary production split.

18. Available evidence suggests that lifecycle environmental impacts of primary metal production are significantly larger than those for the secondary equivalent. An increased share of secondary production both lessens the need for mineral ore extraction and reduces the amount of material that requires disposal. Externalities associated with both activities are therefore eliminated. Furthermore, secondary metal processing is considerably less energy and water intensive, and generates far fewer production by-products such as greenhouse gas emissions, tailings, and smelter slimes. Available data indicate that mining and metal production consumed around 7.5% of global energy supply in 2010. For most metals, the primary process requires between three and twenty times the amount of energy required by secondary production. Support for mining and mineral processing firms, to the extent that it displaces secondary production, serves to increase these impacts.

Discussion and recommendations

19. This report identifies various measures that are commonly used to provide support for mining, metal processing, and material recovery activities. Given the relatively large environmental impacts of the primary metal production process, and the material efficiency and circular economy objectives stated by many countries, it seems reasonable that, from an environmental perspective, a higher level of scrutiny should be applied to support for the primary sector. This report therefore suggests that governments undertake a thorough stocktake of policies that potentially confer transfers for domestic mining, beneficiation, and smelting or refining activities.

20. Data presented in this report indicate that there is considerable variability in metal recycling rates at the global level. For some widely used metals such as steel and aluminium, recovery and recycling rates may be approaching 75%, and the key constraint on increased secondary production is the finite amount of scrap which emerges in waste streams each year. The flow of scrap from in-use metal stocks is expected to increase as the decommissioning of long-lived capital goods proceeds in the near to medium term; there is little that policy could, or should, do to speed this process. Recycling rates for the vast majority of other metals remains below 25% and, in the case of most of the rare earth elements, negligible. In this case, it is the marginal economic viability of metal recovery and processing that limits secondary production. Policy could play a key role here by addressing the factors that hinder the secondary competitiveness; reforming support for primary production would be an obvious place to begin.

21. Variation in recycling rates across different metals also reflects typical end usages. Bulk commodities like iron and aluminium are used mostly in industrial applications; components and products are large in size and composed of relatively simple alloys. These qualities serve to reduce unit collection and reprocessing costs and thereby encourage material recovery. In contrast, many of the less common metals are used in the manufacture of components destined for various technological or electronic products. There is a clear misalignment of incentives here; manufacturers benefit from designing and marketing increasingly functional products, but the additional complexity that this entails imposes costs on material recovery firms downstream. Again, policy could play a role by aligning incentives to the extent possible; for instance by ensuring that Extended Producer Responsibility schemes convey appropriate incentives through the fees that they levy on producers.

22. More generally, the competitiveness of secondary metal production is hindered by a number of factors unrelated to what is defined in this report as government support. Environmental externalities resulting from metal production processes are often unregulated (or only partially regulated), and this probably serves to favour the traditional mining – beneficiation – refining business model. One example relates to greenhouse gas emissions. Primary production is highly energy intensive, often requiring an order of magnitude more energy than the secondary equivalent, but the resulting emissions remain unpriced in many countries. In addition, status quo biases may be important. For example, governments’ tendency to tax labour at a significantly higher rate than capital or materials may dis-incentivise investment in secondary production, which is relatively labour intensive.

23. Significant gaps remain in our understanding of support for the metal sector. It is not currently possible to systematically compare the magnitude of support across countries, or to identify the policy measures that are associated with the largest transfers. In contrast to potentially environmentally harmful subsidies (EHS) provided to other sectors (e.g., agriculture, fisheries, and energy), there is no quantitative cross-country assessment of support provided to metals, or to material resources more broadly. Better data would not only increase the visibility of transfers to the sector, it would also serve as a basis for analysis; uncertainties about the responsiveness of metal output to the provision of support could be better addressed. In terms of data collection, the typology developed in this report could be utilised in combination with previous OECD experience in subsidy analysis. One option would involve the development of a comprehensive database of support in the manner of the OECD Inventory of Support Measures for Fossil Fuels. Alternatively, a series of detailed case studies in important metal producing countries could be undertaken.

1. INTRODUCTION

1.1 Background

24. Economic development and metal use are strongly interlinked. Bulk metals such as the iron, manganese, nickel, and zinc used to manufacture steel, aluminium, and copper are central inputs in almost all major industrial applications. Steel is used extensively across a range of industries, aluminium is vital in the transport sector, while copper allows the efficient transmission of energy over long distances. Between 1980 and 2010, steel, aluminium, and copper production grew by 220%, 170%, and 125% respectively (World Steel, 2016; OECD, 2015a). Taken together, total metal consumption increased broadly in line with, but slightly slower than, global output during this period.

25. Today, modern technology utilises virtually all of the sixty or so known stable metallic elements. The unique chemical and physical properties of each metal allow levels of product functionality that wouldn't otherwise be possible. Copper, tin, and precious metals such as gold, silver, and palladium are common inputs in the vast array of electronic products currently available. Even relatively simple mobile phones can contain more than 40 elements (UNEP, 2013), and these are often alloyed together to form an array of individual components. Many renewable-energy and material-efficiency technologies also incorporate less common metals; the group of rare earth elements (REEs) are central to the production of new generation batteries, wind turbines, catalytic converters, and efficient lighting products.

26. There are two key sources of metal available to society. The stock of virgin mineral resources has traditionally represented the main source of feedstock used in metal production. Today, mining activities are heavily concentrated in the handful of countries endowed with significant mineral reserves. Ores are mined, beneficiated, traded, and then processed, either domestically or elsewhere, to produce a range of finished metals and alloys. Mineral ores are a non-renewable resource by definition; their extraction has led to steady decreases in total stocks, although it is unclear by exactly how much.

27. Anthropogenic metal stocks have increased throughout history as metals contained in virgin mineral resources are extracted, traded, and used in the production of various products. Today, anthropogenic metal resources are heavily concentrated in urban areas, either in the form of long-lived capital goods such as buildings, infrastructure, and machinery, short-lived consumer goods such as personal electronics, and end-of-life goods that have been disposed of in landfills. Secondary metal production is based upon the flow of metal-containing products emerging from in-use stocks. It is an important alternative source of several bulk commodities such as steel, aluminium, and copper, but secondary production of less common metals is often hindered by the complexity of the products in which they are used.

1.1.1 *Circular economy and material efficiency targets*

28. Concerns about material supply risks, the environmental consequences of raw-material extraction and processing, and the management of steadily growing waste streams have increased interest in how to move towards an economy in which a greater proportion of material resources are recovered and re-used. Material efficiency targets have been set in a number of countries, and increased material recovery, re-use, repair, remanufacture, and recycling are seen as key means of achieving them. For the metals industry, the transition to a more circular economy involves an increasingly competitive secondary sector that is capable

of capturing and re-processing the vast array of metal components contained in end-of-life products. Recycling is considered to be especially promising for metals because of their theoretically infinite recyclability.

29. Increased re-use, repair, remanufacture, and recycling of metal and metal-containing products would generate a range of potential benefits. Many of these are environmental: an increased share of secondary production would lessen the need for virgin mineral ore extraction and waste disposal. The environmental consequences associated with each activity would be correspondingly reduced. Secondary metal production is significantly less energy-intensive than the primary equivalent; any displacement of primary production would also tend to reduce greenhouse gas emissions from the sector. Taken together, the life-cycle environmental externalities associated with metal production would be lowered.

30. There are additional benefits associated with increased circularity in the metals sector. For the vast majority of countries that are net importers of intermediate metals, a more efficient domestic secondary sector would serve to lower risk associated with international supply shocks. Primary supply of several critical commodities is concentrated in a handful of countries; any tightening of export policy can have large impacts elsewhere. For countries endowed with virgin mineral reserves, increased secondary production would reduce the amount of ore extraction required to meet domestic metal demand, thereby mitigating potential scarcity for future generations.

31. Any transition to a more circular economy would also generate a range of costs. Clearly, any increase in secondary metal production share will tend to place downward pressure on demand for virgin mineral ore. The mining sector, which is an important employer in rural areas, may contract. In addition, government policies intended to boost material recovery rates will generate additional costs for affected firms and consumers. Landfill taxes and mandated recycling have financial and time costs for households while extended producer responsibility (EPR) regulations transfer the cost of end-of-life product management to manufacturers, and ultimately consumers. Finally, public financial transfers linked to the secondary sector affect government budgets.

1.1.2 Government support and primary – secondary market share

32. Steel and aluminium account for more than 90% of annual finished metal production by weight. At the global level, the share of this production originating within the secondary sector has fallen during the last 15 years, from around 34% to 26% for steel, and 25% to 16% for aluminium (see section 1.3.3). Although these declines are largely due to the construction of additional primary capacity in China, there is little evidence that secondary facilities have gained market share elsewhere. Trade data highlights the growth of the primary sector; export volumes of mineral ores and concentrates grew at almost twice the rate as those of metal scrap between 2000 and 2014 (UN COMTRADE, 2016).

33. In this context, the question arises as to what extent government support for primary and secondary material production is consistent with resource efficiency and other environmental objectives. In particular, what is the relative level of support for primary and secondary materials, and to what extent does differential support negatively affect the economic feasibility of material recovery and secondary production. There is little existing work documenting support in the metals industry, though several recent studies in Sweden (Johansson et al., 2014), Australia (Griffith, 2013; The Australia Institute, 2013), and China serve to highlight the potential size of support available to firms within the primary sector. Recent OECD work on support for fossil fuels has highlighted the broad variety of economic instruments, regulations, and other support policies that are available in that sector.

1.2 Outline of this report

1.2.1 Objectives

34. This work has three main objectives. The first relates to the development of a typology of support measures that are relevant for support available in the primary and secondary metals sectors. The intention is that this typology would form the basis for any future assessment of the support provided to the metals industry. The typology presented in Chapter 2 is based on the OECD Inventory of Support Measures for Fossil Fuels, but contains several modifications to allow for the existence of both the primary and secondary sectors. The second objective, presented in Chapters 3, 4, and 5, is to establish the most common forms of support provided in the primary and secondary sectors. This is based both on data presented in the existing literature on support for metal production, and on a review of a range of other related publications. The third objective, presented in Chapter 6, is to describe the effect of support on incentives for material capture, the primary–secondary production share, and ultimately, the resulting environmental impacts.

1.2.2 Scope

35. Many countries, both industrialised and developing, provide support to their metals mining or processing industries. Such support may be available for both upstream activities, such as mining and the collection of end-of-life waste products, and downstream activities, like metal re-melting, smelting, and refining. Taken together, there is considerable variability in support measures and in the types of country providing them. The examples presented in this report should not be considered exhaustive; they are just a small sample of the wider spectrum of measures.

36. It is recognised that certain other factors, such as the non-internalisation of environmental externalities resulting from metal production, probably enhance the competitiveness of the primary metals sector relative to that of the secondary sector. That said, this report follows the existing World Trade Organization, OECD, International Energy Association, World Bank, and Global Subsidies Initiative practice of not classifying non-internalised externalities as a source of subsidy or support. In this report, they are instead viewed more generally as a form of government failure that may hinder the emergence of an expanded secondary sector.

37. Support is available for producers of a wide range of metals, but may accrue to a greater extent to certain metals. Several common forms of support are targeted at individual commodities (e.g., trade restrictions and variable royalty rates), and de-facto specific support also exists where support is provided in a country endowed with a single metal. The commodity focus in this report is on steel, aluminium, copper, and the group of REEs, but this does not reflect any judgement on the relative magnitudes of support. Rather, these metals were selected due to their centrality in many production and consumption activities and to the richness of the data available for them.

38. It is recognised that governments have many motivations for providing support. Certain measures are intended to address specific market failures while others appear to be designed to achieve other objectives. This report makes no value judgement on the desirability (or otherwise) of the identified support measures. Although it is clear that primary metal production has a greater life-cycle environmental cost than secondary production, it does not necessarily follow that the removal of support accruing to the sector will be welfare-enhancing. Support measures exist in a broad policy framework and interactive effects between policies mean that it is difficult to determine *a priori* whether a particular measure offers efficiency gains or not.

39. Finally, the emphasis in this study is not on the quantification of support. In particular, the intention is not to establish the relative magnitude of primary and secondary support at either the sub-national, national, or global level. Such an exercise is well beyond the scope of this work, particularly given that, as discussed in Chapter 2, the value conferred to firms in the secondary sector by several common forms of targeted support is difficult to quantify. An assessment of differential support is therefore left for future work.

1.3 Overview of the metals industry

1.3.1 Primary and secondary metal production

40. Three main activities comprise primary and secondary metal production: extraction, upgrading, and processing (Figure 1). *Extraction* produces raw material feedstock through the mining of virgin mineral ores or the collection of metallic waste and scrap. *Upgrading* transforms these materials into intermediate products; *beneficiation* and an initial metallurgical process are typical in the primary sector; *material shredding* and *physical sorting* are the key secondary equivalents. *Processing* involves the production of finished metal products through a variety of smelting, refining, and re-melting processes. Each activity may take place in a different location; raw materials and intermediate products are transported significant distances, often across international borders.

41. Metal concentrations increase progressively along the value chain as non-metallic materials are separated and removed. Each activity generates production by-products that may have important environmental consequences. Primary metal production results in waste rock generation at the mining stage, tailings at the upgrading stage, and smelter and refinery slimes during processing. Secondary metal production generates recycling residues at the upgrading stage.

Figure 1. The primary and secondary metal supply chains

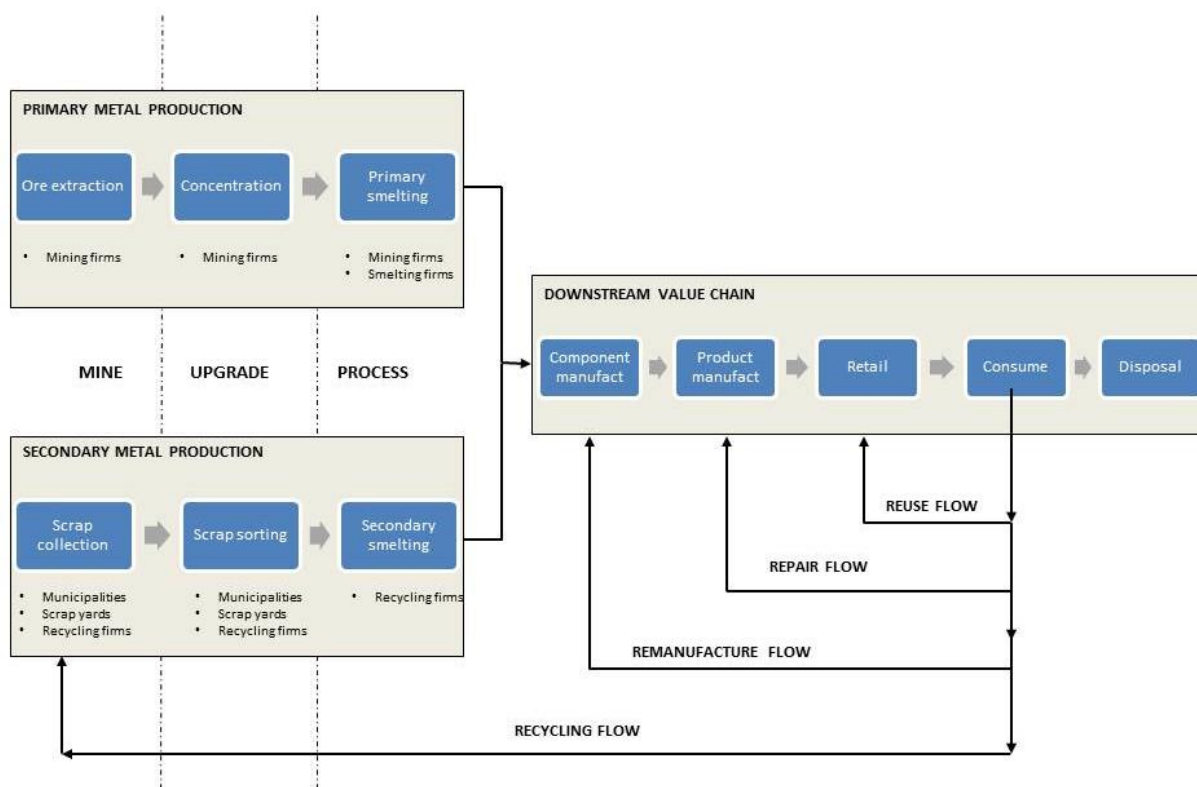

1.3.1.1 The primary process

42. Primary metal production involves the progressive separation and removal of unwanted gangue³ minerals contained in virgin mineral ores. The specific processing route varies considerably across metals, but also across different ores of the same metal. For example, sulphide ores require a very different treatment than their oxidised equivalents. It is beyond the scope of this study to provide individual process descriptions for the major metal groups; good summaries can be found in Norgate et al. (2006) and BIR (2008). Figure 2 provides an example of the key processes, intermediate products, and waste by-products involved in copper production from sulphide ores.

43. The upgrading phase of primary metal production is generally undertaken within several kilometres of the mine site; the transport of unprocessed bulk ores over larger distances is not cost competitive. Primary upgrading involves an initial beneficiation stage (crushing and grinding) followed by a concentration process in which metal-containing minerals are separated from surrounding gangue. For most types of ore, concentration involves the intensive use of chemical reagents which then become incorporated into tailings slurries following metal separation. Intermediate output products such as iron pellets (steel), alumina (aluminium), and base metal concentrates (copper, lead, zinc, etc.) are less bulky and higher grade than the original ores. Many mining companies, especially smaller ones, choose to market these products directly to third-party smelters and refineries rather than process them in-house.

Figure 2. Example of the primary production process for copper in sulphide ore

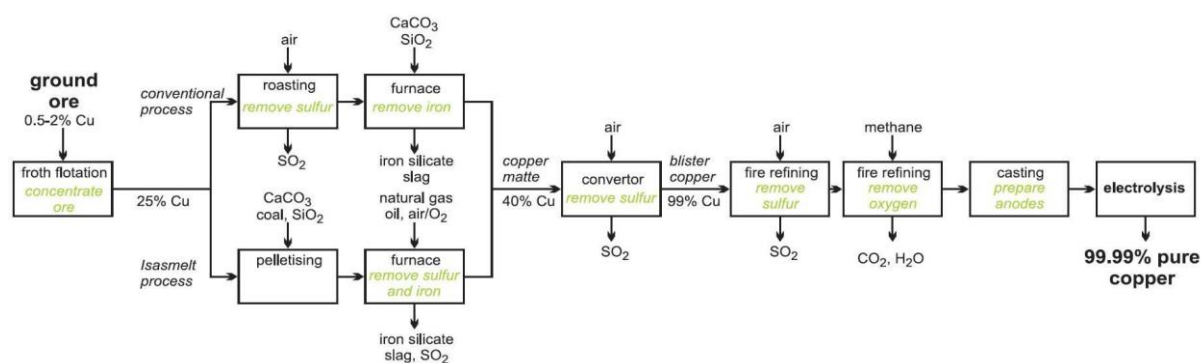

Source: ECI (2016)

44. The process phase of metal production transforms intermediate products into finished metal. For primary feedstock, this requires the reduction of sulphide or oxide minerals to their key constituent metallic elements, a process that is achieved through a series of high temperature metallurgical reactions at smelters and refineries. Finished metal can be marketed as such (e.g., LME copper), or alternatively, alloyed with other metals to produce specific products (e.g., high-tensile steel). The final stage of primary production involves casting – the pouring or injection of hot liquid metal or alloy into molds of various shapes.

1.3.1.2 The secondary process

45. Secondary metal production utilises metals contained in end of life capital goods and consumer products for feedstock. These products are embedded in three main waste streams (Chalmin et al., 2009). Municipal solid waste (MSW) is generated in urban residential areas by households, small business, and

³ The Oxford Dictionary defines gangue as the “commercially valueless material in which ore is found”

individuals depositing waste in rubbish receptacles and recycling bins. Commercial and industrial (C&I) waste originates throughout the economy in the form of unwanted manufacturing by-products and decommissioned capital assets that have reached the end of their useful life. Construction and demolition (C&D) waste arises during building, refurbishment, or demolition activities. The proportion of contained metal, and the amenability of this metal to material capture, varies across each waste stream (see section 1.3.2.2). Certain waste streams are better sources of a given metal than others.

46. The secondary upgrade process varies significantly across different waste streams and different products. For common forms of municipal waste, like metal packaging, sorting is either partially or fully undertaken by households (where individual or multiple fraction recycling is provided) or in material recovery facilities (in the case of multiple fraction recycling or undifferentiated waste collection). C&I waste such as decommissioned machinery, defunct automobiles and end-of-life ships is often sold directly to specialist scrap operations. Metal cutters and shredders are used to reduce the size of the constituent components, which are then separated into scrap bundles of similar composition for re-melting. C&D metallic waste is often co-mingled with associated building materials, and may require manual sorting prior to any further treatment.

47. The physical separation of products and components of the target metal or alloy from the rest of the waste stream can be done either manually, as in many less industrialised countries, or automatically, using specialised sorting equipment (e.g. Figure 3). Magnetic separators allow the efficient sorting of ferrous scrap, while eddy-current separation can sort non-ferrous metal scrap from other waste on the basis of differential material conductivity (DOITPOMS, 2016). Automated sorting becomes increasingly difficult for more complex products. Electronic and other technological waste poses particular problems; the concentration of hundreds of individual components, each with similar physical properties, limits the ability of sensors to distinguish between different alloys.

Figure 3. Example of the secondary sorting process for household appliances

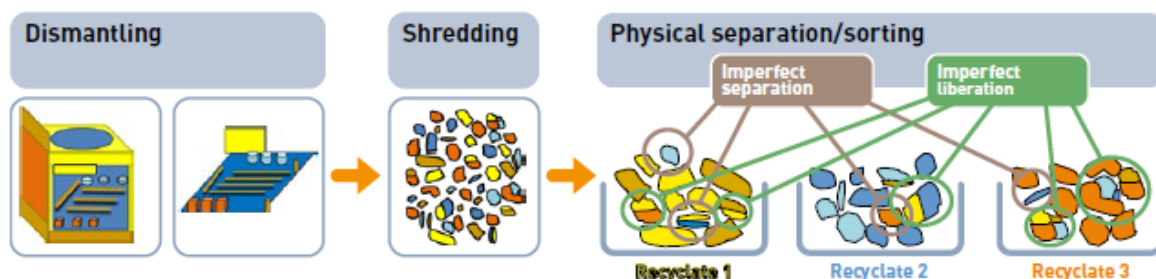

Source: UNEP (2013), Metal Recycling: Opportunities, Limits, Infrastructure

48. Secondary re-melting and smelting facilities process sorted scrap, which can be composed of a single metal (e.g., copper wiring), a single alloy (e.g., aluminium cans), or mixed alloys (e.g., steel of various compositions). Scrap feedstock may also contain a range of impurities due to oxidation or other contamination during the sorting phase. The most common secondary processing route has historically involved direct re-melting to produce an output metal or alloy with the same composition as input scrap. The introduction of additional metal to the furnace prior to casting allows for some flexibility in finished metal composition, but the removal of impurities contained in scrap feed generally is not possible. More recently, processing metal scrap in integrated primary or specialist secondary smelters has become increasingly common. These facilities operate much like primary facilities and have the capacity to separate different constituent metals from unwanted impurities. This capability is important because the vast majority of modern metal consumption is in the form of alloys rather than pure metals.

1.3.2 Metal production by process and country

49. The location of metal production varies according to commodity, process (primary or secondary), and which phase of the value chain it involves (Table 1). The geographic distribution of metal production is important because support measures are more widely available in some countries than others. Support provided in large producer countries will tend to affect the global market share more than support provided elsewhere. This section provides a brief snapshot of current metal production patterns, and how they have evolved during the last fifty years.

Table 1. Global upstream and downstream production data for the primary and secondary sectors: 2013 and 2014

		Fe		Al		Cu		REE	
		Primary	Secondary	Prim	Sec	Prim	Sec	Prim	Sec
Upstream	Material extracted (Mt)	3,160	-	283	-	203	-	-	-
	Contained metal (Mt)	1,480	-	-	-	18.3	-	0.1	-
Downstream	Finished metal (Mt)	1,223	385	48	9	17.0	3.9	-	-

Note: Mt = million tonnes. Dashed boxes reflect missing data.

Sources: USGS (2016), Minerals Information Database; World Steel (2016), Crude Steel Production; ABREE (2016), Resources and Energy Statistics

1.3.2.1 Primary output

50. Upstream primary metal production closely reflects the geographic distribution of mineral resources (Figure 4). Ten countries account for ~90%, ~85%, and ~70% of global upstream bauxite, iron ore, and copper ore production. Upstream concentration is even higher for other commodities: China accounts for ~87% and ~84% of global REE and tungsten production, Brazil for ~90% of niobium production, Rwanda for ~50% of tantalum production, and the DRC for 49% of cobalt production (USGS, 2016).

Figure 4. Geographic distribution of iron, aluminium, and copper ore production in 2013

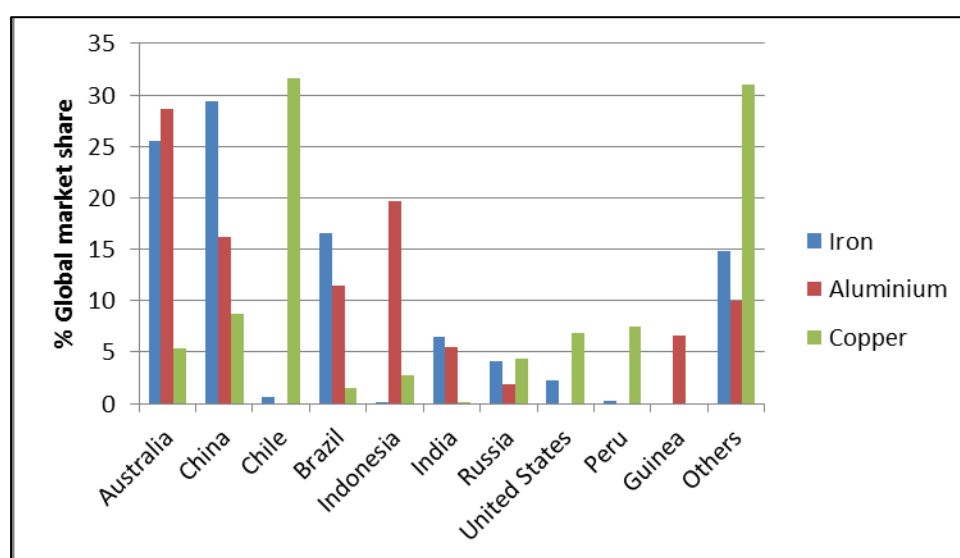

Note: Figures reflect metal contained in ore with the exception of aluminium, which represents bauxite extraction

Source: USGS (2016), Minerals Information Database

51. The production of finished metal products from primary feedstock is dominated by China, particularly for steel and aluminium (Figure 5). Elsewhere, most large industrialised countries possess domestic refining capacity for the major metal groups. In addition, certain countries with significant mineral-resource endowments (DRC, Zambia, and Indonesia) or cheap energy resources (UAE, Iceland) produce significant quantities of finished metal.

Figure 5. Geographic distribution of finished primary steel, aluminium, and copper production in 2013

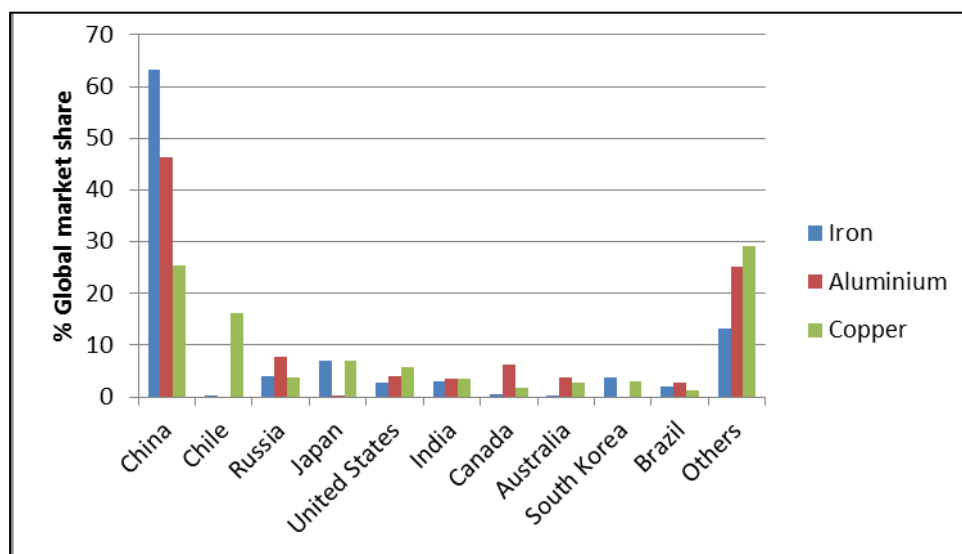

Sources: USGS (2016), Minerals Information Database; World Steel (2016), Crude Steel Production; ABREE (2016), Resources and Energy Statistics

52. At the firm level, the distribution of finished metal production largely reflects that at the country level. For steel, the four largest firms – Arcelor Mittal (India), Hesteel Group (China), NSSMC (Japan), and POSCO (South Korea) – produced ~97 Mt of crude steel in 2015, or around 14% of world production (World Steel, 2016). The five largest aluminium producers – UC Rusal (Russia), CHALCO (China), Rio Tinto (Australia), Hongqiao Group (China), and Alcoa (United States) – produced 16.6 Mt of finished aluminium in 2014, around 31% of world production (Aluminium Leader, 2016). For copper, the four largest firms – Codelco (Chile), Freeport McMoran (United States), Glencore (United Kingdom), and BHP Billiton (Australia) – produced 5.8 Mt of finished copper in 2014, around 27% of world production (MineWeb, 2016; USGS, 2015). The largest producer firm for each of these commodities – Arcelor Mittal, UC Rusal, and Codelco – represented around 6%, 7%, and 9% of total production respectively.

1.3.2.2 Secondary output

53. The equivalent of mineral-ore extraction in the secondary sector is the collection of end-of-life (EOL) scrap and metal-containing products. Data quantifying scrap “production” at the country level is largely non-existent; however, the amount collected is a function of (i) the flow of metal generated from the depreciation of in-use capital stocks and the disposal of short lived consumer goods, and (ii) the proportion of this flow that is captured (rather than dispersed or disposed). Industrialised countries characterised by high levels of historic investment and current consumption should account for the majority of secondary metal production. This is supported by trade data, which highlight the United States, Japan, and several EU countries as the biggest exporters of scrap metal (see Chapter 5).

54. The amount of metal contained in waste varies significantly across the main waste streams. There are two reasons. First, the municipal solid waste, commercial and industrial waste, and construction and demolition waste streams are different sizes. Data for Australia (Federal Government, 2016), the United Kingdom (UK Government, 2016), and the EU 28 (Eurostat, 2016) suggest that waste generation in industrialised countries is dominated by construction and demolition activities (40-60%), followed by manufacturing (25-30%), and households (15-25%). Second, the proportion of contained metal varies significantly across waste streams. Available data for industrialised countries indicate that municipal solid waste and construction and demolition waste contain only around 5% metal by weight (Productivity Commission, 2006; World Bank, 2010; Eurostat, 2016). By contrast, commercial and industrial waste in the same set of countries contains around 22% metal by weight (Federal Government, 2006; Eurostat, 2016).

55. Recent work by UNEP highlights the variation in global recycling efficiency across different metals. The EOL recycling rate (EOL-RR) – the proportion of metal embedded in waste streams that is captured for recycling (UNEP, 2013) – varies widely according to metal (Figure 6). The EOL-RR for steel is thought to be between 70% and 90%, while the equivalent for aluminium and most base metals is in the order of 50% to 70%. Recovery rates for a wide range of other less common metals, such as those in the REE group, are considered to be negligible. This global pattern probably masks significant variation across individual countries. Material capture infrastructure and secondary metals markets are much better developed in certain regions, but there is no internally consistent database allowing cross-country comparisons. Detailed Material Flow Analyses (MFAs) do exist for certain countries (e.g., Golev and Corder, 2015).

Figure 6. End of life recycling rate for various metals

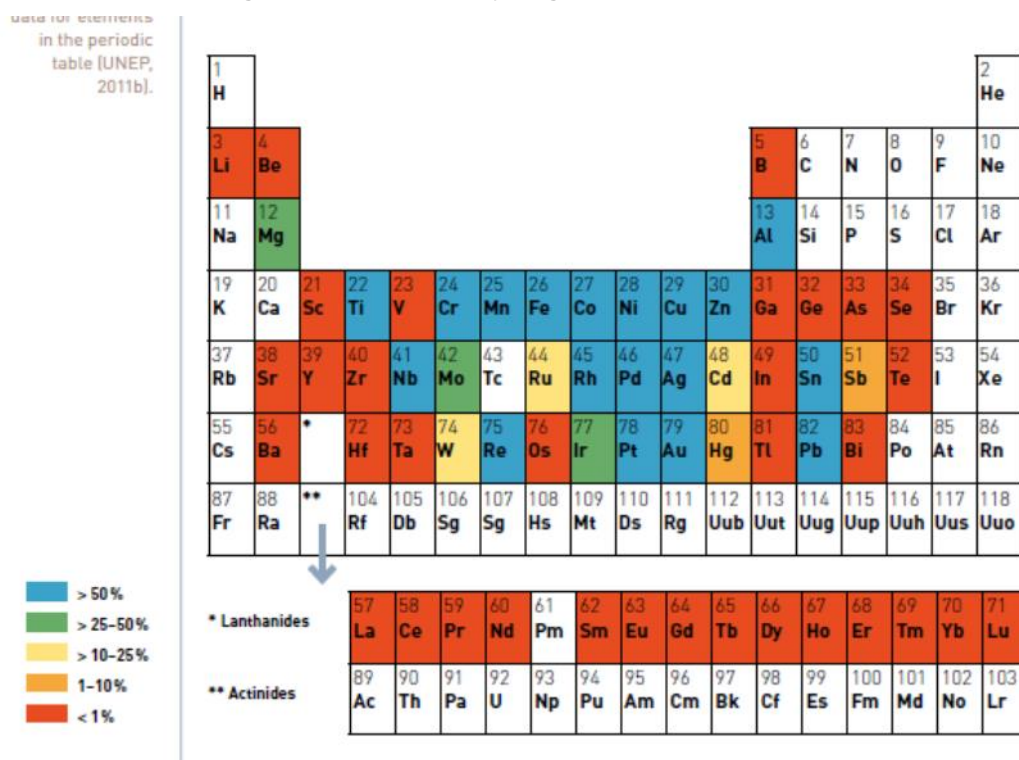

Source: UNEP (2013), Metal Recycling; Opportunities, Limits, Infrastructure.

56. Variation in end-of-life recovery rates by metal partially reflects typical end usages. Bulk commodities like iron, aluminium, nickel, and zinc are used mostly in industrial applications; constituent

components are large in size and composed of relatively simple alloys. These qualities serve to lower collection and reprocessing costs and thus encourage material capture. By contrast, many of the less common metals are used in the manufacture of components destined for various technological or electronic products. Examples include lithium used in modern battery technology, neodymium used in the high performance magnets found in modern wind turbines, and the range of REEs used in electronic goods. The functionality of these products relies on interactions between various components of different alloys. Product marketability is also enhanced when these components, and therefore the product itself, are small in size. Taken together, these product characteristics limit the commercial feasibility of product disassembly and recycling.

57. Data on annual finished metal production from facilities using secondary feedstock is available for steel, aluminium, and copper (Figure 7). The estimates for steel are based solely on production from EAF steel plants, and are therefore probably downward biased given that scrap is also used to a limit extent in BOF plants. Downstream secondary metal production is highly concentrated, although China is less dominant than for primary steel and aluminium production. Again, most major industrialised nations have significant domestic processing capacity, which utilises a combination of domestic and imported secondary feedstock.

Figure 7. Geographic distribution of finished secondary steel, aluminium, and copper production in 2013

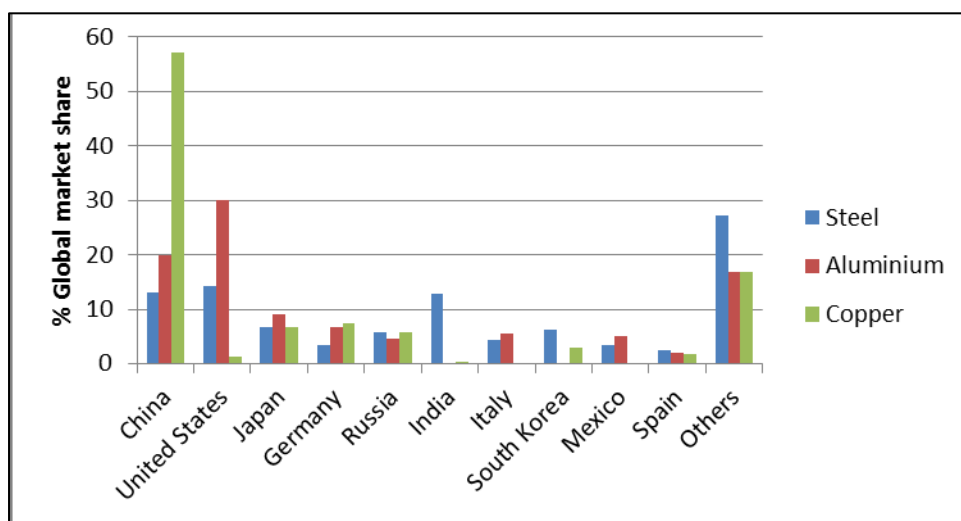

Note: Aluminium data are from 2006.

Sources: USGS (2016), Minerals Information Database; World Steel (2016), Crude Steel Production; ABREE (2016), Resources and Energy Statistics; OECD (2010), Sustainable Materials Management: Materials Case Study 2: Aluminium.

1.3.3 Competition between primary and secondary metal producers

58. Competition between firms in the primary and secondary metals sectors takes place on a metal by metal basis at the smelting or refining stage of the metal value chain. Each sector produces goods – finished metal products – that are perfect, or near perfect substitutes for each other. These are traded on metals markets that are largely global in extent. As highlighted in this section, the primary sector accounts for a large proportion of the total supply of all metals, and, for some metals such as steel and aluminium, has become increasingly dominant during the last two decades.

1.3.3.1 Current primary–secondary market share

59. Market share in finished metals markets is dominated by the primary sector. In 2013, secondary metal facilities accounted for around 20% of global steel, aluminium and copper production (Figure 8). Global data on secondary production of other metals is unavailable. Recent work undertaken by UNEP used a number of country-level assessments to estimate an average recycled content (RC); the proportion of metal derived from scrap in total metal production⁴. One key finding is that the proportion of secondary production is less than 25% for all widely used industrial metals and less than 10% for most speciality metals (Li, Nd, Dy etc).

Figure 8. Primary - secondary market share for finished steel, aluminium, and copper in 2013

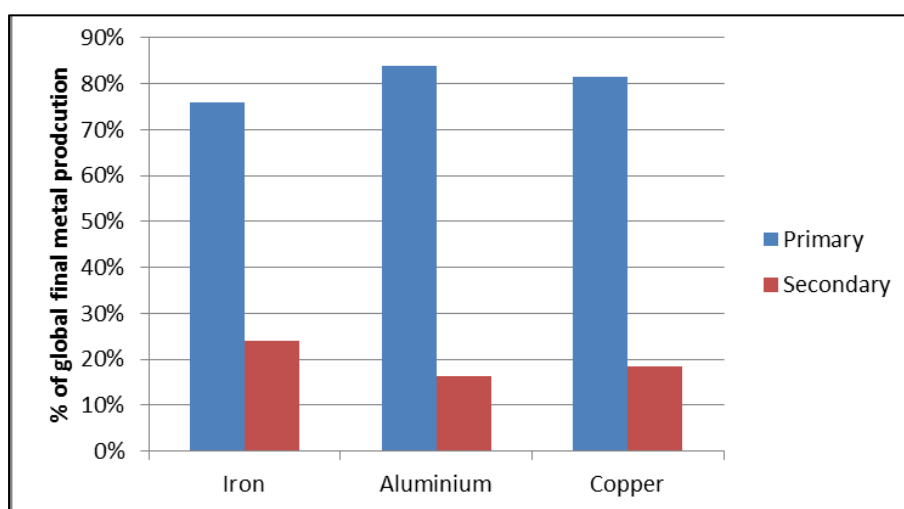

Sources: USGS (2016), Minerals Information Database; World Steel (2016), Crude Steel Production; ABREE (2016), Resources and Energy Statistics

60. Low secondary market share is the consequence of a number of factors. For widely recycled metals such as steel and aluminium, secondary supply may be constrained by the limited availability of scrap emerging from the in-use stocks. In addition, and as highlighted in Section 1.3.2.2, metals used in highly complex alloys and products may be technically very different to recover. In all cases, the economic incentives affecting production decisions are critical. It is in this context that support for primary and secondary metal production is important.

61. There is significant variation in primary–secondary production at the country level. Figures 9 and 10 show the production mix for the ten largest producer countries of finished steel and aluminium. In both cases, world output is dominated by China, where production originates mostly from facilities using primary feedstock. Elsewhere, primary-sector dominance is much less pronounced. Domestic steel production in the United States and India is mostly from secondary facilities; the same is true for aluminium production in the United States and Germany.

⁴ This metric is equivalent to that used for steel, aluminium, and copper in Figure 8

Figure 9. Finished primary and secondary steel production in the ten largest producer countries: 2014

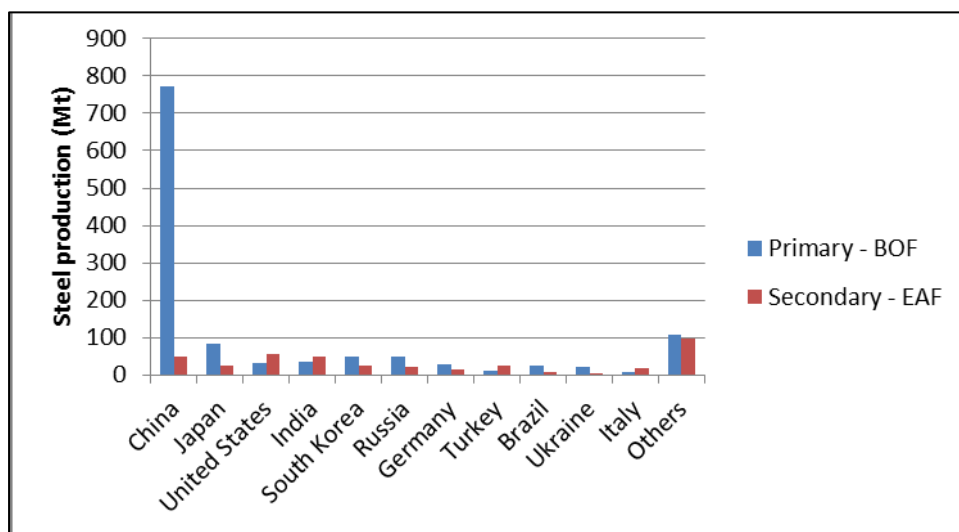

Source: World Steel (2016), Crude Steel Production

Figure 10. Finished primary and secondary aluminium production in the ten largest producer countries: 2006

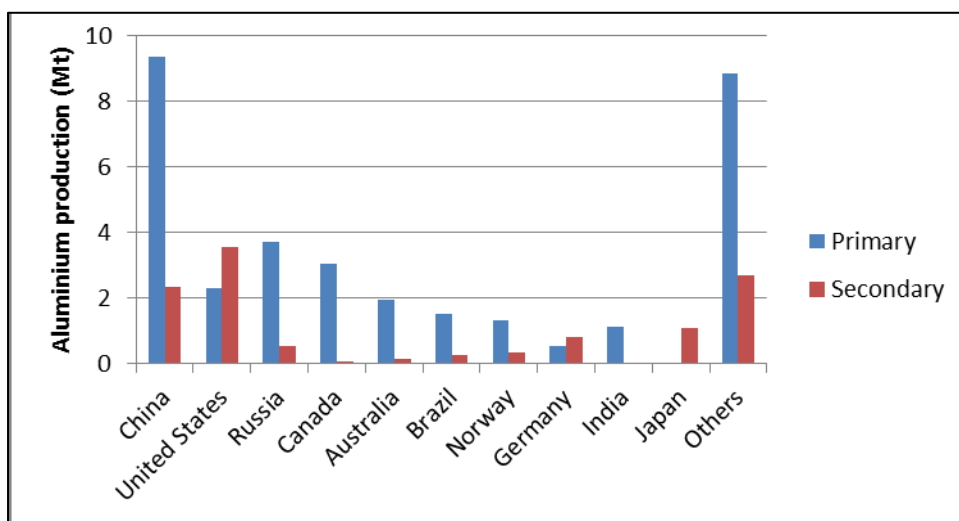

Sources: USGS (2016), Minerals Information Database; OECD (2010), Sustainable Materials Management: Materials Case Study 2: Aluminium

1.3.3.2 Trends in primary-secondary market share

62. Figure 11 tracks the evolution of the primary and secondary market shares for steel, aluminium, and finished copper. Quite different trends are apparent. The proportion of secondary steel and aluminium in global output increased steadily from the mid-1970s before plateauing in the mid-1990s. Secondary steel and aluminium market share has fallen significantly over the past decade as most new investment was directed towards primary facilities. More than 90% of the increase in global primary steel (BOF plants) production capacity between 2000 and 2014 occurred in China.

Figure 11. Evolution of primary and secondary market shares for finished steel, aluminium, and copper

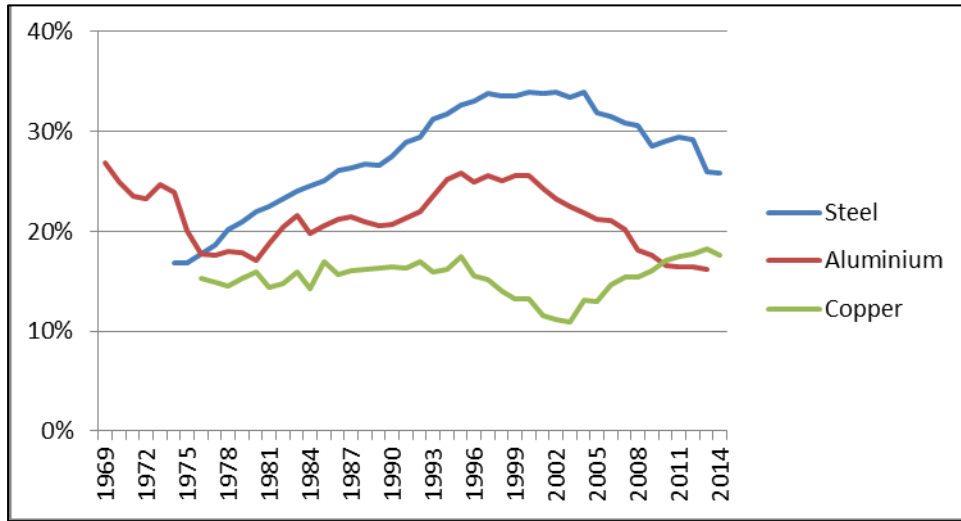

Sources: USGS (2016), Minerals Information Database; World Steel (2016), Crude Steel Production; ABREE (2016), Resources and Energy Statistics

2. TYPOLOGY OF SUPPORT MEASURES RELEVANT FOR METALS

2.1 Existing support typologies

63. Definitions of government support have been published by a number of inter-governmental organisations including, the World Trade Organization (WTO), European Union (EU), the International Energy Agency (IEA), World Bank, the International Monetary Fund (IMF), and the Global Subsidies Initiative (GSI) of the International Institute for Sustainable Development (IISD). There is an important distinction between the WTO and EU definitions and those of the other organisations. The former two, having been agreed upon by each respective set of member countries, are legally binding whereas the other definitions have no legal basis and used more as a framework for the quantification of support.

64. Individual definitions of support are presented in Annex 1. There is generally a high level of correspondence between the OECD definition (presented below) and other approaches to government support. The most important distinction relates to the IMF definition, which considers the non-internalisation of certain production or consumption externalities to represent support. Most other organisations, while acknowledging the effect that the internalisation of externalities would have on market prices, do not consider that any absence of policy counts as support.

Box 1. Support estimates at the OECD

The OECD has published support estimates for agriculture since the mid-1980s and for fisheries since the late-1990s. More recently, a series of reports have focused on so called environmentally harmful subsidies (EHS) and their consequences for sustainable development (OECD, 2005, OECD, 2007, and OECD, 2012). This body of work assessed, and in some cases quantified, support for the agriculture, energy, fisheries, forestry, and transport sectors in OECD countries.

Classification of support measures by where they are targeted in the sectoral value chain is central to most OECD assessments. The OECD manual on producer and consumer support estimates was first published in 2008, and has been periodically updated since then (OECD, 2016a). Producer Support Estimates (PSEs) capture the annual monetary value of gross transfers from consumers and taxpayers to producers that arise due to government policy measures, regardless of their objectives. PSEs can be further decomposed into the parts of the upstream value chain to which they accrue. Consumer Support Estimates (CSE) capture the value of transfers to consumers downstream of the final good while the General Service Support Estimates (GSSE) capture the value of transfers provided collectively to a sector; those that are not received by individual producers or consumers.

Since 2011, the OECD has been publishing estimates of support measures in the fossil fuel sector (OECD, 2015). The typology developed for this work classifies support measures along two key dimensions: the mechanism by which transfers are made and their formal incidence. Documented transfer mechanisms are: (i) direct transfers, (ii) foregone tax revenues, (iii) other foregone government revenues, (iv) transfer of risk to government, and (v) induced transfers. Induced transfers include the effects of regulatory policies such as monopoly concessions and wage controls.

The formal incidence of support describes which aspect of production or consumption is formally targeted by the support measure. Categories include: (i) output returns (the unit revenues received from sales), (ii) enterprise income (the overall income of producers), (iii) the costs of intermediate inputs, such as partially processed metals, (iv) the costs of value-adding production factors – labour, land (which includes access to sub-surface natural resources), capital, and new knowledge, or (v) consumption in general.

2.2 A support typology for primary and secondary metals

65. This section presents the typology that has been developed to document and classify various forms of government support for the metals industry. The typology draws heavily on recent OECD work on fossil fuel support, and also on several earlier studies related to support for (mostly primary) metal producers (Scharf, 1999; Koplow, 1994; US EPA, 1994; and Johannson et al., 2014). It is envisaged that this typology will provide a framework for future assessments of primary and secondary metal support.

66. Which measures represent government support and which do not has been the subject of considerable debate. What one researcher or organisation considers as support may not always be recognised as being so by others. Definitions are particularly important when quantifying the magnitude of support; total monetary estimates depend to a significant extent on which measures are counted and which are not. A clear example is provided by fossil fuels – the IMF estimate of global post-tax subsidies is around three times larger than the IEA estimate of subsidies and other forms of support. The key difference is that the IMF estimate considers the cost of certain carbon-related externalities whereas the IEA and OECD estimates do not.

67. This paper follows the OECD’s approach to fossil fuel support in proceeding from the perspective that identifying “subsidies” to any sector or industry requires first taking an inventory of the full set of measures that may qualify as support. As stated in OECD (2015b), “because of interactive effects among policies, it is difficult to determine *a priori* whether a particular support policy is inefficient, encourages wasteful consumption, or is environmentally harmful”. This is particularly true in a two-sector context in which support serves in a non-linear way to increase the market share of output from an activity that has more of an environmental impact relative to an activity that produces similar goods using a less environmentally harmful production process. Only with a full picture of the operating policies can various analytical tools be brought to bear on questions about the effects of those policies on human welfare and the environment.

68. In practice, there exists a trade-off between documenting a broad range of support measures and being able to quantify a significant proportion of them. Many historic assessments of support for various sectors restrict their focus to direct budgetary transfers and foregone tax revenues – the data and modelling requirements for quantifying other forms of support have been considered too great. The emphasis in this paper is on documentation. It is recognised that quantifying many forms of support for the metals sector may be impractical. However, overlooking these on this basis would risk downplaying their importance in distorting competition between primary and secondary metal sectors.

69. Table 2 shows the typology that has been developed. It accounts for direct cash transfers, and in-kind and implicit transfers, as well as regulatory forms of government support. This broader definition therefore encompasses policies that may involve transfers to firms outside the metals sector (those that lower the cost of inputs or increase the price of outputs for firms within the metals sector), policies that raise government revenues (e.g., landfill or other green taxation), and policies that do not involve government financial transfers at all (regulatory support). The following section discusses key aspects of the typology.

Table 2. Typology of support for the metals sector with selected examples

SUPPORT EXAMPLES		SOURCE OF SUPPORT		INCIDENCE OF SUPPORT	
Transfer Mechanism	Policy Example	Specific Mechanism	Sector Targeted	Initial Incidence in Value Chain	Formal Incidence
Budgetary Transfers	Capital grant for recycling facilities	Grant	Secondary	Upgrade and process	Capital
	R&D grants	Grant	Horizontal	All	Knowledge
	Public mining finance	Concessionary finance	Primary	All	Capital
Foregone Tax Revenue	Extended tax holidays for processing facilities	Reduced tax rate	Horizontal	Process	Capital
	Accelerated depreciation	Tax deduction	Horizontal	Process	Capital
	Exploration tax credits	Tax credit	Primary	Mining	Knowledge
	Fuel excise tax exemptions	Tax exemption	Horizontal	Mining	Intermediate inputs
Other Foregone Revenue	Concessionary provision of electricity through SOE's	Foregone revenue	Horizontal	Upgrade and process	Intermediate inputs
	Sub-optimal royalty rate	Foregone revenue	Primary	Mining	Natural Resources
Transfer of Risk to Government	Public green investment finance	Risk transfer	Secondary	All	Capital
Induced Transfers	Export tax on finished metal	Export restriction	Horizontal	Consumption	Unit cost of consumption
	Export tax on metal scrap	Export restriction	Secondary	Upgrade and process	Intermediate inputs
	Product take back requirements	Regulatory	Secondary	Upgrade and process	Intermediate inputs
	Landfill tax	Green taxation	Secondary	Mining	Intermediate inputs
	Recycled content labelling	Regulatory	Secondary	Process	Output returns

2.3 Discussion of selected aspects of the typology

70. This section highlights several considerations relating to support for the metals sector and how they have been incorporated into the typology.

2.3.1 *Support can be received directly or transmitted along the value chain*

71. Support provided by governments is received by eligible producers and consumers in the form of either direct cash payments, reduced tax or other cost burdens, or improved access to finance. In the context of the metals sector, common support measures include grants linked to the development of secondary metal processing facilities, preferential tax treatment associated with extended tax holidays, and the provision of low-cost electricity to smelters and refineries.

72. Support targeted towards a particular sector can also be received indirectly by agents operating elsewhere in the economy. Support received in an upstream sector may be passed down the value chain in the form of lower intermediate product prices. That received by downstream producers or final consumers will tend to place upward pressure on output prices for producers higher in the value chain. An example in the metals sector would be a reduction in the cost of intermediate metal concentrates sold to smelters and refineries as a result of support to the mining sector.

73. Understanding the extent to which support is transmitted through the value chain is important in the context of this study. Distortion of downstream primary – secondary competition depends partially on the proportion of upstream support, which is passed through to metal smelters and refineries. Support pass through is largely a function of the supply and demand elasticities within the supply chain, and these may differ substantially between the primary and secondary sectors. In particular, the existence of additional market power or vertical integration within the primary sector may serve to limit the transmission of support. This means that the same upstream support measure, when received by either the primary or secondary sector, may not have the same impact on downstream competition and market share.

74. In addition to the above, there are a range of regulatory policies that are classified as induced support. These do not involve government budgetary or risk transfers; instead, the creation of a regulation affecting firms within a certain sector results in transfers to firms and consumers elsewhere in the economy. Examples in the metals sector include mandated extended producer responsibility (EPR) schemes such as product take-back requirements, environmental regulations such as landfill bans, and informational requirements like recycled-content labelling (see Chapter 4). Ultimately, these serve to lower the market price of inputs or increase the market price of outputs for secondary metals firms. Establishing the value of these support mechanisms is, however, complex.

2.3.2 *Support is targeted mostly at producers*

75. The typology follows previous OECD subsidy analyses in categorising support measures according to which agents they benefit. In the context of the metals sector, the Producer Support Estimate (PSE) would capture the value of all support available upstream of final metal production (inclusive). The vast majority of support measures documented in this paper represent producer support; key beneficiaries include mining firms, metal recyclers, and smelting and refining operations.

76. The Consumer Support Estimate (CSE) would capture the value of support available to agents consuming finished metals; metal fabricators and component manufacturers are the immediate key buyers. Very few consumer support measures are documented here. One example relates to export restrictions on finished metals; these serve to lower the price of these products for domestic consumers (and producers).

77. Finally, the General Service Support Estimates (GSSE) would capture the value of transfers provided collectively to the metals sector, those that are not received directly by producers or consumers.

2.3.3 Support is not evenly distributed along metal value chains

78. The typology allows producer support to be differentiated by where in the metal value chain it is initially targeted. Competition between the primary and secondary metal sector mostly takes place at the smelting or refining phase (Figure 1), but support targeted further upstream affects intermediate feedstock prices and the relative competitiveness of each sector. For both primary and secondary smelters, feedstock is derived from two key upstream activities: mining (MINE) and material upgrading (UPGRADE). The processing stage in the value chain (PROCESS) involves the transformation of feedstock into finished metal in a range of forms – ingots, flats, rods, wire, etc. Producer support measures can therefore be classified according to which of these production activities (or combinations of) they target.

79. In the secondary sector, there are a number of policy measures that affect manufacturing (MANUFACTURE), consumption (CONSUMPTION), and end-of-life product disposal (DISPOSAL) activities, but which ultimately confer support for secondary metal producers. EPR regulations can encourage manufacturers to design products that are more easily dismantled. This can induce transfers to scrap-metal collection and sorting firms that benefit from lower prices associated with feedstock supply. Similarly, landfill taxes increase the cost of waste disposal for households and businesses, but induce a transfer to secondary firms who again benefit from lower feedstock prices.

2.3.4 Support varies by formal incidence

80. The typology also follows the OECD’s inventory of fossil fuel support measures in classifying support according to its formal incidence. Unlike economic incidence, which is concerned with the final beneficiaries of a measure, formal or statutory incidence does not take into account supply and demand elasticities, and is therefore solely focussed on which aspect of production or consumption is formally targeted by the measure. As stated in OECD (2015b), “formal or statutory incidence can in that sense be understood as *de jure* incidence while economic incidence is better understood as *de facto* incidence. As with a measure’s environmental effects, it is only through careful analysis that the economic incidence of a policy can be established”.

81. To that end, formal incidence is divided into a number of categories depending on whether a measure relates to: output returns (the unit revenues received from sales); enterprise income (the overall income of producers); the costs of intermediate inputs, such as feedstock; the costs of value-adding production factors: labour, land (which includes access to sub-surface natural resources), capital, and new knowledge; or consumption in general.

2.3.5 Competing sectors: support may be targeted or horizontal

82. In a multi-sector setting, support can either be sector specific (targeted) or general (horizontal). Targeted or specific support measures are those which are only available to firms operating in a particular sector. Common primary sector examples include concessionary mineral royalty fees, the below-cost provision of geoscientific data, and tax credits linked to exploration expenditure. Secondary-sector examples include investment grants available to the recycling sector, public “green” finance on concessionary terms, EPR legislation, and the provision of municipal waste and recycling services.

83. Horizontal support measures are those whose availability is not restricted to firms in a given sector. In the context of primary and secondary metal production, important examples include extended tax holidays for downstream metal-processing facilities, tax loss carry-forward and accelerated depreciation provisions, and general R&D tax credits. Recent research on Australia’s primary metals

sector found that horizontal measures represented the largest share of support for mining firms (Griffiths, 2013). This finding is controversial however: industry lobby groups tend to argue that such measures do not represent sector specific support (Sinclair Davidson, 2012).

84. Support conferred by horizontal measures (in per-unit of output terms) will accrue mainly to firms that use the subsidised input relatively intensively. For example, mining firms are likely to benefit disproportionately from accelerated depreciation provisions because of the high capital intensity of the primary production process. In other cases, specific provisions may mean that horizontal support measures are in practice only available to certain firms or sectors. This is the case in Australia, where the Business Fuel Tax Credit for transport activities is only available in full for use on non-public roads – used exclusively by mining firms. Finally, in certain instances, theoretically horizontal forms of support may be of little practical use to a certain sector. This may be the case in Indonesia, where extended tax holidays for metal smelters and refiners encourage in-country processing of domestic virgin mineral resources. By contrast, a shortage of domestic scrap production may limit the accessibility of this support for secondary facilities.

2.3.6 Support varies by metal

85. The typology allows support measures to be differentiated by metal. This is important because the degree to which competition between primary and secondary metal producers is distorted will vary across metals. Different metals may receive differential levels of support because:

- Governments often apply different royalty rates to particular metals.
- General support policies benefit certain metals more than others. In the context of waste management, the provision of household waste collection and recycling services will only provide support for those metals found in the municipal solid-waste stream.
- Trade policy varies across metals: export bans or quotas are more common for metals deemed to be of strategic importance. The effect of trade policy on metals markets is modulated by the global market share of the jurisdiction imposing the trade restriction. Chinese export restrictions on primary REEs are strongly distortionary because of China's dominant share of global production.
- Primary metal supply is more concentrated than secondary supply, particularly for certain metals. In the case of iron ore, Fortescue, Rio Tinto, BHP, and VALE supplied 68% of primary iron ore globally in 2013 (UNCTAD, 2014). If failure to regulate oligopolistic behaviour were taken to represent support for primary suppliers, then primary suppliers of certain commodities would benefit more than those for other commodities.

3. WHAT IS KNOWN: SUPPORT FOR PRIMARY METAL PRODUCTION

3.1 Introduction

86. This chapter provides a discussion of the key forms of support for firms in the primary metal sector. It begins with a literature review, which attempts to distil and present the main findings from a limited collection of existing work. The second part of the chapter then focuses on three broad forms of support, which are discussed in additional detail. The use of public funds to finance mining investment is highlighted, particularly in developing countries, where mining investment is often intended to achieve development or trade related objectives. Tax rate reductions, tax deductions or credits, and tax exemptions made available through national level tax legislation are then considered – these are probably the single most common way in which primary support is conferred. Finally, the role of sovereign mineral-resource ownership and mineral rents is assessed. In particular, do governments provide support for mining firms by undercharging for access to publicly owned mineral wealth?

87. One common theme that emerges is the importance of support measures that serve to reduce the cost of capital, energy, and mineral-resource inputs for primary resource firms; measures targeting labour inputs are rare. Another important finding relates to where in the metal supply chain support is targeted; measures directed at mining and processing activities are common, whereas consumer support in the form of market price controls are largely unknown in the metals industry. Finally, relative to support for firms in the secondary sector, most forms of primary support do not address obvious market failures; they appear to serve other objectives.

3.2 Literature review of support for primary metal production

88. Historic work documenting support for the primary metals sector can be sub-divided into three main categories. The first relates to historic work that has a similar focus to this study: documenting, and where possible quantifying, primary and secondary support measures in order to establish their effects. The second category includes a number of country-level studies that focus on the magnitude of primary support measures only. These typically attempt to quantify all forms of support for the mining sector and are usually motivated by some sense that mining firms receive an unfair amount of support. The third category includes previous work that restricts its focus to a single form of support – direct budgetary transfers, concessionary tax provisions, trade rules, etc. – either within or across countries. Short summaries of the relevant literature are presented in Annex 2.

89. Several attempts have been made to quantify the relative level of primary and secondary support for an individual country (Koplow, 1994; US EPA, 1994; Scharf, 1999; Johannson et al., 2014). This work typically focuses on countries with well-developed mining sectors – no assessments of primary or secondary support in countries that are net-metal importers are known. This work has been carried out by different researchers and is not normally exhaustive; the focus may be restricted to certain commodities (e.g. aluminium), or to certain types of support (e.g. that provided through the tax system). This makes cross-country comparisons difficult. In all cases, the authors conclude that support for primary metal production using virgin resources exceeds that for secondary production using recycled scrap. It is less clear whether this conclusion remains true when the overall contribution to total metal production is considered; differential support is probably less pronounced when considered in per-unit terms.

90. Some studies have assessed primary support measures without considering the secondary equivalent (Pembina Institute, 2002; Griffith, 2013; The Australia Institute, 2013). This work normally focuses on a specific country and is motivated by some feeling that the mining sector receives an unfair amount of government support. Concerns about low recycling rates or the circular economy are generally secondary or not considered at all. The scope of these assessments is broad: the intention is generally to identify the full range of support measures available to firms in the primary metal sector. Cross-country results are unlikely to be directly comparable due to the different subsidy definitions used across studies.

91. A number of other studies quantifying support for primary metal production restrict their analysis to a specific policy instrument (e.g., targeted tax exemptions for the mining sector or trade restrictions relating to metals). For the purposes of this research, these assessments can be useful because they are undertaken in considerable detail and may also include cross-country comparisons.

3.3 Common forms of support for primary metal production

92. This section provides a detailed discussion of three potentially important forms of support for primary production. The first relates to the use of public funds to provide, or facilitate the provision of, investment finance for firms in the primary metals sector. The second involves specific tax provisions, both for corporate and other taxes, that serve to disproportionately reduce the tax liability of mining firms. The third focuses on mineral resource rents, and the extent to which an equitable proportion of these are captured by the resource owner, which in most countries is the state.

3.3.1 Finance

93. Mining and mineral processing firms face large up-front capital costs associated with the purchase of mining equipment, the construction of downstream processing facilities, or the development of transport infrastructure. Project finance for individual projects often extends into the billions of dollars and the pool of potential projects is large; total global mining finance peaked at USD 115 billion in 2010 (Larson, 2014). Mining and metal finance is generally sourced on international capital markets, but public money can also be important. The provision of public investment finance is not necessarily intended to address market failures; in many cases it is provided in order to meet other development or economic objectives. The following section describes the main instruments through which governments provide or facilitate finance for mining and primary metal processing firms.

3.3.1.1 Development finance

94. Public funds have been an important historical source of mining finance in low income or developing countries. There are two reasons. First, heightened investment risk associated with political instability or civil unrest common in many low income countries has restricted international investment flows. Projects that are otherwise commercially feasible are not developed because up-front capital costs cannot be met. Second, the size of many mining projects, along with their revenue generating potential and the fact that they are often situated in rural areas, has meant that development finance institutions have taken a keen interest in the sector. Although there is significant evidence for a resource curse at both national and sub-national level, it remains true that long-lived mining projects can generate well paid jobs in regional areas otherwise lacking employment in the formal sector.

95. State-owned investment banks, development finance institutions, export-credit agencies, and other public-investment organisations have invested considerably in mining projects. Institutions such as the UK's Commonwealth Development Corporation (CDC) or the Netherland's Entrepreneurial Development Bank (FMO) finance mining investment in third-party countries, while domestic institutions such as South Africa's Industrial Development Corporation (IDC) fund projects in their own country.

Export-credit agencies in developed countries often finance mining investment in low-income regions in return for some assurance that capital equipment will be procured from the lender country. In addition, there are a number of regional and international multi-lateral lenders such as the European Investment Bank (IEB) or the International Finance Corporation (IFC) that provide international mining finance.

96. Investment funds provided by these institutions are considerable. In 2014, the IDC had a total book value of around USD 5.4 billion, of which around one quarter was invested in domestic South African mining projects. Recent project financings also provide an insight into the scale of these deals. Funding for the Roy Hill iron-ore project in Australia was concluded in 2014; a significant proportion of the USD 7.2 billion debt package was provided by American, Japanese, and Korean export-credit agencies (Roy Hill, 2014). Similarly, in late 2015 the IFC provided a package of debt and loan guarantees to the Oyu Tolgoi mining project in Mongolia worth USD 2.2 billion (IFC, 2015).

97. These institutions, share two characteristics – they are publicly capitalised lenders whose investment mandate is broader than that for a typical commercial investment bank. Secondly, development or trade objectives (for credit agencies) are central to the lending strategy and, although long term financial sustainability is required, targeted investment returns may be less stringent than for commercial lenders.

98. Public financing can represent an important form of primary support. Reduced cost of capital improves project economics and can lead to the construction of projects that would not otherwise be feasible. Debt or equity financing may be provided on concessionary terms relative to those available on the market. Debt contracts can be favorably structured along several dimensions, from concessionary interest rates or repayment schedules, to relatively lenient collateral requirements. Public financing can represent support even where it is provided on commercial or near-commercial terms. For example, the provision of partial project funding or of loan guarantees can facilitate private-sector participation by reducing the overall project risk profile.

3.3.1.2 State equity participation

99. The national mining law provides the governments of a number of emerging economies with the option to acquire a certain percentage of a domestic mining project. Legislation in other countries, including the Democratic Republic of the Congo and Ghana, makes it mandatory for governments to own a certain proportion of the project (PWC, 2012). State equity participation in mineral projects is generally (but not always) limited to a minority share. Table 3 provides a summary of relevant legislation in a number of mining jurisdictions.

100. State equity participation is structured in three main ways (Sunley and Baunsgaard, 2001; McPherson, 2008). The first involves that on fully commercial terms; the government acquires its equity stake through an up-front cash payment reflecting the project's valuation. The second involves carried equity participation; the mining firm financially "carries" the state investor during the project construction phase, but recoups the state's expenditure share through withheld future production proceeds or dividends. Carried participation can be on fully commercial terms, where the cost of capital is accounted for, or on preferential terms, where it is not. Finally, government participation is on clearly preferential terms where the mining law provides for free equity provision; the state has no financial obligation to pay for its equity share.

Table 3. State equity participation in mining projects in mining jurisdictions

Country	State Participation	Country	State Participation
Botswana	Diamonds negotiable WI other minerals	Mauritania	None. 78% SNIM
Chile	None in private mines. Codelco 100%	Mongolia	10% Local/50% Govt
Dem. Republic of Congo	5%F/ Negotiated equity shares 15%-51%	Namibia	None
Ghana	10% F/20% WI	Papua New Guinea	30% WI
Guinea	15% F	Peru	None
Indonesia	None	Sierra Leone	10% F/30% WI
Jordan		South Africa	15% Black Ownership
Kyrgyz Republic	Variable WI 15%-66%	Uzbekistan	
Liberia	15% F	Zambia	Minority Interests

Note: WI = working interest, F = free carried interest

Source: McPherson (2008), State Participation in the Natural Resource Sectors

101. From the government's perspective, participating in large resource projects imposes an opportunity cost by drawing funds away from other social and development programmes. It may also place public money in considerable jeopardy. Although mining projects at the development stage are significantly de-risked, a range of challenges relating to project execution often remain. From the mining firm's perspective, state equity participation on fully commercial terms may represent an important form of support. This is especially the case in high-risk jurisdictions where commercial finance may be limited and state participation is significant in size. One example is provided by Papua New Guinea, where the 1992 Mining Act allows the state to voluntarily acquire a 30% fully participating interest in mining projects with no financial carry (PNG Department of Minerals, 2013). In such scenarios, the provision of investment finance by the government can make the difference between project construction or not.

3.3.1.3 State-owned enterprises (SOEs)

102. Full state ownership of mining enterprises is an extension of state equity participation. Rather than take a minority or majority share in a metals enterprise, governments may opt to establish a 100% national owned mining or processing company. This can be done directly, through the creation of a publicly capitalised organization, or alternatively through the nationalisation of pre-existing privately owned metal firms. Governments may opt for full ownership for various reasons. Maintaining domestic production capacity for certain strategic materials such as steel is often deemed to be in the national interest. In addition, control of sovereign mineral resources and the full capture of resource rents may be important motivators.

103. State-owned enterprises are not uncommon in the mining and mineral processing sectors. Data from the World Bank indicate that around 31% of global iron ore mine production, 30% of bauxite production, and 24% of copper production was under state control in 2008 (World Bank, 2011). For most commodities, state control is even more widespread in downstream sectors; around half of global aluminium smelting capacity was under government control in 2008. Table 4 shows the share of global metal production from 100% SOEs by country. State-owned mining and mineral processing enterprises dominate metal production in China and Iran, but are also important in a number of market economies (World Bank, 2011). Examples of the latter include LKAB, which has a virtual monopoly over Sweden's

iron and steel industry and whose mine production represents around 1% of the global total (USGS, 2016). Similarly, the Chilean state owned miner Codelco is the world's largest copper firm, accounting for around 10% of global production in 2014 (USGS, 2016).

Table 4. Share of global metal production from 100% state owned enterprises (SOEs) by country

Rank 2008	Total Production 2008 (t)	State Control 2008 (t)	State Share 2008 (%)	State Share 2006 (%)	Rank 2006
1. China	14.8	14.8	100	100	1
2. Chile	7.7	2.0	26	32	2
3. India	5.7	1.6	28	39	4
4. Iran	0.9	0.9	100	100	5
5. Poland	0.8	0.8	100	100	3
6. Uzbekistan	0.7	0.7	100	100	6
7. Indonesia	2.1	0.6	30	16	7
8. Venezuela	0.61	0.53	87	80	8
9. Sweden	0.74	0.5	78	50	9
10. Mauritania	0.32	0.24	75	100	na

Note (1): Percent of total value of all metal production globally.

The state share varies with both the produced volumes but also with the relative value of the metals produced in each country.

Source: World Bank (2011), Overview of State Ownership in the Global Minerals Industry

104. SOEs are a potentially important source of support for the primary metals sector because they do not necessarily face the same commercial realities that firms do. Governments may be prepared to support the ongoing operation of unprofitable or loss-making SOEs where this contributes to furthering other government objectives. Unfortunately, the financial sustainability of SOEs in many jurisdictions is difficult to assess. Data availability is often poor resulting in difficulties quantifying financial transfers.

3.3.2 Foregone tax revenues

105. In many jurisdictions, mining and mineral processing firms are eligible for a broad range of tax rate reductions, targeted deductions or credits, or special exemptions. These provisions can be classified according to several criteria including, (i) whether they are direct (available directly to mining firms) or indirect (confer support for mining firms via reduced input prices), (ii) whether they are horizontal or targeted (only available to primary metal firms), (iii) whether they serve to reduce the cost of inputs, or increase output returns, and (iv) whether they address a specific market failure or are intended to achieve other objectives. This section separates tax relief available to firms in the primary metal sector into two main categories – those deductions, credits, and exemptions available through corporate income tax and those available through other taxes.

106. Most forms of primary support provided via the tax code do not target specific market failures. Instead, these policies are often justified by claims that they are required to address barriers to entry unique to the mining sector (World Bank, 2006). For example, mining projects have particularly long lead times during which firms face significant costs without generating any revenues. Industry data indicates that 10 to 15 years are typically required to advance a copper project of significant size from discovery to production (MinEx Consulting, 2011 and World Bank, 2016a). This is often the justification for the provision of loss carry forward rules over extended periods.

107. Another common example relates to the capital intensity of mine and process plant construction; required financing once a project reaches the construction stage often extends into the billions of dollars. Accelerated-depreciation provisions are often justified on this basis. Finally, mining projects face a number of risk factors that are not common in other sectors. Raw materials are particularly prone to substantial price changes which create uncertainty about future revenues, while the immovability of large long-lived capital investments mean that mining firms are more exposed to sovereign country risk than firms in other sectors. This often serves as justification for the negotiation of tax stability agreements.

3.3.2.1 *Corporate income tax (CIT) provisions*

108. Mining and mineral processing firms are liable for corporate income tax in much the same way as firms in other sectors. The final tax bill partially depends on the corporate tax rate, which can vary within a given country across sectors, geographic areas, or firm characteristics. For example, mining firms in the Democratic Republic of the Congo face a reduced corporate tax rate of 30% relative to other firms, which pay 40% (PWC, 2012). In Brazil, mining firms which operate in designated regions characterised by lower levels of economic development can benefit from up to 75% reductions in the federal corporate tax rate. Corporate tax holidays, where firms in specific sectors are exempt from corporate income tax for a certain period, are also available in a number of countries. In the context of the metals sector, these tend to be designed to encourage investment in domestic downstream processing facilities. Indonesia offers a ten year tax holiday to firms considering investing in base metal smelting or refining capacity (PWC, 2015) while the Philippines offer a four to six year holiday to miners who upgrade mineral ores in the country (PWC, 2012).

109. Corporate tax paid by mining firms is also a function of what definition of earnings is applied. The tax code in many countries allows firms to reduce their taxable income – their tax base – by deducting costs above and beyond what would normally be considered normal business expenses. One example is provided by the deductibility of royalty payments; in almost all mining jurisdictions these are 100% deductible for corporate income tax purposes (PWC, 2012). Tax credits act in a similar way, but relevant expenses, or more frequently, a proportion of them, are deducted directly from the final tax bill itself. In reality there is an equivalence between tax deductions and credits; both serve to erode the amount of tax paid and credits can be calibrated to provide the same amount of tax relief as a full tax deduction.

110. Loss carry forward provisions allow firms to use financial losses in previous years to reduce the amount of taxable income in the current period. Loss carry forward is generally non-targeted, but is particularly important for mining firms because it allows them to offset exploration, feasibility, and development expenses incurred during the pre-production phase against future mining revenues. It also addresses the commodity price volatility that mining firms face during the production period by allowing financial losses incurred during price downturns to be carried forward. Although the GAAP accounting framework specifies that loss carry forward should be restricted to seven years, many mining jurisdictions including Australia, Canada, Indonesia, and the US allow for much longer periods (PWC, 2012).

111. Mineral exploration and feasibility study expenditures are treated in two main ways for tax purposes. In some countries, such as Peru, India, and the Philippines, exploration costs are capitalised as intangible assets and amortised over the life of the mine (PWC, 2012). The second treatment, which is applied in Australia, Canada, Mexico, and South Africa, is to treat these costs as operating expenditures that are fully tax deductible. This treatment is especially favourable for mining firms because it allows for the reduction of assessable income early in a project's life. Additional corporate tax relief related to exploration expenditures are available in certain countries. Argentina offers a “double deduction”, where the value of exploration activities is both capitalised and amortised, but also made available as fully tax deductible. Canada, in addition to allowing full deductibility of exploration expenditures through the

Canadian Exploration Expense (CEE) program, also allows, in certain instances, corporate deductions to be passed to individual investors through the use of flow-through shares.

112. Accelerated-depreciation provisions (ADPs) for tangible and non-tangible capital expenditure are available to mining firms in most jurisdictions. These allow the value of capital assets to be written off relatively rapidly, which, in turn, improves project profitability by reducing taxable income early in a project's life. In most other sectors, depreciation for tax purposes takes place over the life of the business or a much longer period. The capital intensity of the mining business model means that ADPs represent an important source of support for the sector. Particularly favourable depreciation rates are available for mining plant and machinery in Tanzania (100%), Ghana (80% during the first year), and Canada (25%). These countries offer similar rates for infrastructure spending, such as for the improvement of transport, electricity, or water networks (PWC, 2012). In Australia, Canada⁵, and Tanzania, capital expenditure on capital assets first used in exploration or development is eligible for an immediate 100% deduction.

3.3.2.2 *Tax provisions related to factors of production*

113. Non-corporate income tax provisions are also relevant for the metals industry. The most important of these relate to taxes levied directly on factors of production used by mining and processing firms. Labour, capital, natural mineral resources, and energy are the key inputs in metal production, and primary metal firms use the latter three relatively intensively with respect to recyclers. For many metals, primary production includes an intermediate, capital intensive beneficiation stage that is largely absent in the secondary production process. Ore crushing and grinding requires considerable machinery and energy; any tax policy which serves to lower the price of either can provide indirect benefits for primary metal producers.

114. Various studies argue that relatively low rates of taxation on capital, virgin resources (Ayres, 1997; Wijkman and Skanberg, 2016), and energy (Ayres, 1997, Johansson et al., 2014) confer a significant advantage to the primary metals sector. This is likely to be true even when tax policy is completely horizontal (non-discriminatory); the capital-, resource-, and energy-intensive character of primary metal production means that horizontal policy confers a disproportionate advantage (Scharf, 1999). A recent of Club of Rome report on the circular economy (Wijkman and Skanberg, 2016) states that, "modern tax systems in the EU apply high rates to employment while leaving the use of natural resources tax-free or even subsidized. In such a distorted business environment it is little wonder that most firms find it financially attractive to overuse natural capital and underuse human capital."

115. Table 5 summarises tax rates on labour and capital factor payments along with mineral royalty or mineral tax rates⁶ in a number of mineral rich countries. Data on effective labour tax rates is sourced from the OECD, data on withholding tax rates for capital is from PWC (2012), and data on capital gains is from individual country tax departments. Withholding tax represents the main way in which many jurisdictions tax returns to capital, particularly when these payments are made outside the country of origin. It is clear that several major mining countries tax returns paid to capital at significantly lower rates than returns to labour. In Canada, the effective tax rate for the average income level is 32% while withholding taxes on interest and dividend payments are 25% or less. In Australia, the same pattern is apparent; however, the tax structure serves to encourage debt rather than equity funding.

⁵ The Accelerated Capital Cost Allowance for assets acquired before the beginning of commercial production is being progressively reduced; from 100% in 2016 to 30% in 2020 (NRCAN, 2017a)

⁶ Mineral royalty payments are typically assessed on the basis of some measure of the value contained in extracted ore. In contrast, mineral taxes are assessed on some measure of firm profits

Table 5. Summary of labour, capital, and mineral resource tax rates for various mining jurisdictions

	LABOUR		CAPITAL			RESOURCE	
	Personal income tax		Withholding tax				
	Highest marginal rate	Effective rate	Debt interest payments	Dividend payments	Capital gains	Mineral royalty	Mineral tax
	OECD	OECD	PWC	PWC	Tax Foundation	PWC	PWC
Australia	49%	28%	10%	30%	Taxed as income, but 50% discount for >12 months	Yes: 3-7.5%	No
Canada	49.50%	32%	25%	25%	Taxed as income, but at 50% of individual rate	No	Yes: 10-23%
Chile	40%	7%	4-35%	0-35%	Taxed as ordinary income	No	Yes: 0-14%
Ghana	25%		8%	8%	15%	Yes: 5%	No
Indonesia	30%		20%	20%	Taxed as ordinary income	Yes: 3-4%	No
Ireland	47%	28%	20%	20%	33%		
Kazakhstan	10%		15%	15%	Taxed as income, but gains on shares >3 years exempt	Yes: 2-6%	No
Mexico	35%	20%	30%	10%	Taxed as income, but at reduced rate	No	Yes: 7.5%
New Zealand	33%	18%	18%	15%	0%		
Peru	30%		5 - 30%	4%	Taxed as income unless transaction is through LSX - 5%	Yes: 1-12%	Yes: 2-8%
South Africa	40%		10%	10%	Taxed as income but at lower rate - 13.65% for individuals	Yes: 0.5-7%	No
Sweden	57%	43%		30%	30%		
Tanzania	30%		10%	10%	15%	Yes: 3-4%	No
United States	40%	32%	30%	30%			

Sources: OECD (2016), OECD.Stat; PWC (2012), Corporate Income Taxes, Mining Royalties and Other Mining Taxes

116. The relative level of taxation on payments for the use of mineral assets also appears to be low. Indeed, most jurisdictions do not explicitly tax these payments in the same way as capital and labour payments. Access to sovereign owned mineral resources in most countries is paid for through a mineral royalty or mineral tax system; the resource owner – the state – collects payments based on either the market value of the minerals extracted or on some measure of profit. In most mining jurisdictions, royalty rates vary across different metals, but are generally between 2.5% and 7.5% (Table 5). Mineral tax rates tend to be higher, but are also assessed on a smaller tax base. Both types of payment are intended to represent compensation (usually to the state) from mining firms for the right to access and exploit a public asset. In theory, if these factor payments were treated in the same way as those to labour and capital, an additional tax would be levied on the payments value. In practice, it is not even clear whether royalty schemes in many countries capture an equitable share of resource productivity (resource rents are discussed further in Section 3.3.3).

3.3.2.3 Tax provisions related to intermediate inputs: energy

117. Energy is a critical intermediate input in both primary and secondary metal production - metal production required around 7.5% of global energy supply in 2014 (IEA, 2016). Mining and recycling collection vehicles use significant amounts of petroleum or diesel while mineral beneficiation and

processing facilities often require large amounts of electricity. For most metals, the processing phase of production is considerably more energy intensive for operations using primary feedstock. Table 6 presents data collated by the International Bureau of Recycling; primary aluminium, copper, lead, nickel, and tin production typically requires an order of magnitude more energy than secondary processes (BIR, 2008). Primary steel production is also relatively energy intensive, and generates disproportionately high emission levels due to the direct input of metallurgical coal in the BoF (primary) process.

Table 6. Relative energy and carbon intensity of primary and secondary upgrading and processing

Material	Primary Energy TJ/100,000t	Secondary Energy TJ/100,000t	Primary CO2 ktCO2/100,000t	Secondary CO2 ktCO2/100,000t
Aluminium	4700	240	383	29
Copper	1690	630	125	44
Ferrous	1400	1170	167	70
Lead	1000	13	163	2
Nickel	2064	186	212	22
Tin	1820	20	218	3
Zinc	2400	1800	236	56

Source: International Bureau of Recycling (2008), Report on the Environmental Benefits of Recycling

118. Primary metal production is relatively electricity intensive, and this electricity is often generated using a higher proportion of fossil fuels than that used by the secondary sector. Upstream extraction and beneficiation activities are concentrated in lower income countries where the majority of electricity is generated using coal or natural gas. Mine sites in these countries are situated in remote areas without access to the electricity grid; electricity for on-site beneficiation is often produced using heavy fuel oil and industrial scale generators. In the context of downstream processing, around half of global final steel and aluminium production in 2014 was from China (World Steel, 2016; USGS, 2016). Around 90% of this production used primary feedstock, and the energy consumed was mostly generated in thermal coal plants (Energy Post, 2016).

119. Low rates of energy taxation serve to increase the relative competitiveness of firms in the primary metals sector. Pollution externalities provide a clear economic rationale for the taxation fossil fuel energy use, and the widespread absence of such policy results in lower energy prices than would exist otherwise. Even in jurisdictions where some form of carbon pricing exists, mining and metal processing firms may benefit from targeted exemptions. This is currently the case in Ireland and Norway, where firms using natural gas and coal for metallurgical activities are exempt from carbon taxes (OECD, 2016b).

120. Many jurisdictions also levy some form of excise tax on liquid fuel or electricity consumption. Exemptions from this taxation for mining and mineral processing activities are available in a number of countries. Mining firms in Argentina, Australia, and several Canadian states are not required to pay tax on liquid fuel use (OECD, 2016b). Similarly, downstream mineral processing firms in Belgium, Estonia, Ireland, Norway, the Slovak Republic, Slovenia, and the Netherlands are exempt from relevant electricity taxes.

121. In many jurisdictions, petroleum, diesel, and gas consumption is actually subsidised; regulated price bands which are maintained through state intervention mean that prices are lower than they would be otherwise (GSI, 2010). In other countries, state owned enterprises – electricity generators or fuel refiners – can elect to supply energy at subsidised prices. Subsidisation generally results in foregone government

revenues, either because the SOE does not generate “normal” market returns on investment, or because it operates at below-cost recovery – periodic financial transfers are required to sustain operations. One example is provided in New South Wales, Australia where formerly state owned electricity utilities negotiated long-term concessionary supply contracts with aluminium smelters (Griffith, 2013). In jurisdictions with low energy production costs, foregone government revenues also arise from the opportunity cost of not marketing oil internationally (at international prices). This is common in a number of the Gulf Cooperation Council (GCC) countries, where the provision of cheap electricity has led to the emergence of significant steel smelting and aluminium refining capacity.

3.3.3 *Foregone other revenues: mineral rents*

122. Mining firms earn economic rents – returns in excess of ‘normal’ economic profits – for two reasons (Tilton, 2004; World Bank, 2006). The first relates to the variation in the quality of individual mineral deposits; some deposits have very low production costs due to their size, grade or proximity to surface. Other deposits are more expensive to produce from; irregular deposit geometries, unusual mineral associations, or distance from existing network infrastructure all introduce additional costs. Ultimately the supply of “low cost” type deposits is limited; firms fortunate enough to have access to such deposits earn excess profits termed Ricardian rents. The second reason relates to the exhaustibility of metal supply; there is a fixed physical amount of metal within the Earth’s crust. Scarcity rents, or user costs, reflect the additional value associated with the extraction of mineral resources due to their non-renewable nature.

123. There are two justifications for the taxation of mining firms above and beyond firms in other sectors. The first relates to sovereign mineral ownership; mineral resources in most jurisdictions outside the US are the property of the state. With several notable exceptions, governments do not undertake mineral extraction and processing themselves, but instead provide mining firms with the right to do so. As owner of the productive asset, it is often claimed that the state should receive compensation (in addition to taxes paid by other industries) for its provision. The second justification is an extension of the first; if mining firms earn excess profits due to the quality of mineral deposits within a certain jurisdiction, then doesn’t the owner – the state – have the right to share in these?

124. In theory, there exists an optimal level of total taxation that maximises the net present value (NPV) of all social benefits a country receives from the mineral sector (World Bank, 2006). If taxation is too high, mining firms will opt to invest elsewhere and few benefits will accrue domestically. If it is too low, the country will likely become a popular mining destination, but will reap few rewards for being so. The latter scenario can represent a potentially important form of support for the primary metals sector; governments forego potential revenues when they undercharge for access to sovereign mineral resources. From the firm’s perspective, this confers support by decreasing tax liabilities and increasing profits.

125. The most common tool used to explicitly collect mining rents is royalty payments. As outlined in section 3.3.2, these are generally assessed on the value of contained metals in run-of-mine metal production. Royalty rates differ across metals and countries (Table 5), but actual collection (what proportion of earnings they collect) varies with time according to commodity prices and production costs. For example, during the last mining cycle in Australia, royalty payments as a proportion of pre-tax earnings ranged between about 50% in 2002 and 20% in 2009. Whether these rates represent equitable compensation for access to sovereign mineral resources is somewhat subjective – the assumption of all project risk by the mining firm provides some economic justification for the significant retention of mining profits.

126. In practice, governments attempt to collect mining rents with a variety of instruments. In addition to royalties (or in some cases, in lieu of them), mining firms may face, (i) differential corporate tax rates, (ii) dedicated mineral taxes, (iii) government equity participation requirements, (iv) specific

border taxes, and (v) transfer pricing rules. Taken together, this diversity of instruments makes it difficult to establish how mining taxation in a certain country compares to that elsewhere, and to any theoretically optimal rate. Is a two percent royalty assessed on the market value of mine production more onerous than a four percent mining tax assessed on net profits? One approach has been to calculate some measure of the total effective tax rate – the average rate at which mining pre-tax earnings are taxed – and then assess how this varies across jurisdictions.

127. Recent work undertaken by Goldman Sachs (Goldman Sachs, 2013) simply sums the relevant corporate tax and royalty rates and then compares this across countries (Figure 12). This highlighted China, Kazakhstan, Indonesia, and Mexico as the mining destinations with relatively concessionary mining tax policy. Although low nominal tax rates may indicate the existence of support in these jurisdictions, they may also reflect other factors. For example, there may be fewer available deductions and exemptions available.

Figure 12. Total tax (corporate income tax + royalty payments) by mining jurisdiction

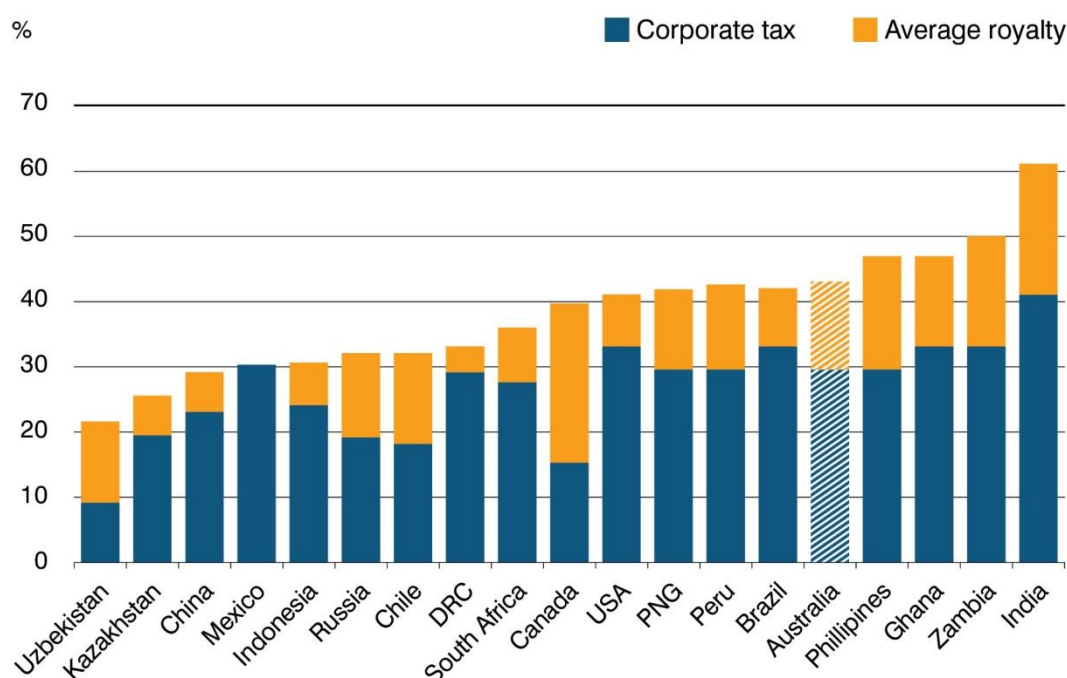

Source: Goldman Sachs (2013), Resource Nationalism Poses Big Threat to Miners

128. An earlier study undertaken by the Colorado School of Mines (Otto et al., 2000) took a more detailed approach, and considered what total effective tax rates a ‘typical’ mining firm extracting a specific commodity would face in different jurisdictions. This allows tax provisions which affect the assessable tax base – advanced depreciation, deductibility of development costs or royalty payments from CIT, etc. – to be incorporated in the calculation. Although this work is now dated, it showed that the total effective tax rate for mining firms ranged between around 30% in Sweden and South Africa to upwards of 60% in Indonesia, Mexico, Ontario, and Papua New Guinea.

129. Both of the above approaches are valuable because they provide a first order indication of which countries are undercharging for access to their mineral wealth. However, the major limitation of both is that they do not account for non-tax related instruments governments use to extract benefits from mining

firms. Chief among these are mandated state equity participation provisions that provide governments with free equity in domestic mining projects. These are available in a number of African mining jurisdictions, including Burkina Faso (10%), the Democratic Republic of the Congo (5-10%), Ghana (10%), Kenya (10%), and Senegal (10%) (Mayer Brown, 2015). These countries may have relatively low CIT and royalty rates but capture a significant proportion of mining profits through dividend payments. Another limitation of these approaches relates to variation in the quality of mineral resources across regions. Resources in some jurisdictions may have lower metal concentrations, be further from the surface, or difficult to process. Such factors lower economic rents available for mining firms, and potentially rationalises the use of lower tax rates.

4. WHAT IS KNOWN: SUPPORT FOR SECONDARY METAL PRODUCTION

4.1 Introduction

130. This chapter provides a discussion of the key forms of support for secondary metal production. It begins with a literature review, which presents the findings from a limited body of existing work. The second part of the chapter focuses on three broad forms of support that are discussed in additional detail. As in chapter three, the public provision of investment finance and the availability of tax relief are described; this allows a comparison of the relative importance of these two measures for mining and metal recycling firms to be made. In addition, regulatory measures that potentially lower the costs of secondary metal production – EPR schemes and the provision of municipal solid waste collection – are also discussed.

131. There are several key themes that emerge from this chapter. For example, it is immediately apparent that very few studies have systematically documented, let alone quantified, different forms of government support for secondary metal production. This may be due to several factors, including: (i) the use of relatively “narrow” definitions of government support, (ii) quantification difficulties associated with many forms of secondary support, or, (iii) the fact that secondary support is provided at various administrative levels.

132. Government support for secondary metal production exists in various forms within a significant number of countries, and is available throughout metal recycling supply chains. Public green investment finance and targeted corporate income tax breaks incentivise re-melting and reprocessing investment. Landfill taxes and disposal bans, EPR schemes, and the public provision of separated recycling collection increase the supply and quality of metal scrap feedstock further upstream. The latter measures represent induced forms of support; they don’t necessarily involve public financial transfers but instead create transfers to metal recycling firms from agents elsewhere in the economy.

133. Finally, it is clear from an economic perspective that many of the measures documented here are intended to address market failures. Landfill taxes are justified by environmental externalities associated with waste disposal, EPR schemes address a missing markets problem, while the public provision of waste management services generates positive public health externalities. The provision of public investment finance may also address a market failure – the small investment sums involved and the volatility of metal scrap prices may restrict financial flows from capital markets.

4.2 Literature review of support for secondary metal production

134. Historic work documenting support for the secondary metal sector is extremely limited. There is no known comprehensive assessment of government support for secondary metal production, either within an individual country, or across countries.

135. The small body of work which has attempted to quantify support for metal recycling relative to that for primary metal production is mostly presented in Section 3.2. Johannson et al. (2014) and Scharf (1999) are the most comprehensive assessments. These studies highlight recycling grants and the public provision of kerbside recycling services as noteworthy forms of secondary support. The former concludes that, regardless of which definition of subsidy is used “the mining sector appears to be the beneficiary of a

higher rate of subsidies” relative to recyclers. The latter stated that the Canadian tax system “significantly favours the use of virgin materials rather than recycled materials in the case of metal products”. In addition, a paper by Fothergill (2004) found that support provided by recycling grants and the provision of kerbside recycling in Canada was at least an order of magnitude less than a third party estimate (National Resources Canada) of primary sector support. However, it appears that recent changes to Canada’s Federal tax code have now largely abolished this preferential tax treatment of virgin material.⁷

136. In addition to the above studies, there is a broad body of work documenting various forms of differential environmental taxation and targeted tax relief. These studies do not generally attempt to quantify the magnitude of the associated tax revenues, or where they are foregone, tax expenditures. Nevertheless, they highlight differences in tax schemes both within and across countries. This work is presented in Annex 2.

4.3 Common forms of support for secondary metal production

137. This section provides a discussion of three common forms of secondary support. The first relates to the use of public funds to provide, or facilitate the private provision of, investment finance for metal recyclers and re-processors. The second involves specific tax provisions, provided through corporate income or other taxes, which confer differential support for these firms. The third relates to policies that serve to increase the supply of scrap emerging from the municipal solid waste stream; landfill taxes, EPR regulations, and the public provision of waste collection and management services are examples.

4.3.1 Finance

138. Targeted public investment schemes are available for material sorting, recycling, and reprocessing firms in a number of countries. Transfers are made in various forms. Non-repayable grants, concessionary debt financing, or loan guarantees are all documented, but the state equity ownership requirements similar to those in the mining sector are uncommon. Most public debt finance is dispensed from the national budget, whereas state or provincial governments are the main source of grants.

139. The provision of public finance confers support for the secondary metal sector in a variety of ways. Where it is provided on concessionary terms, such as in the form of grants or low interest loans, public finance increases individual project profitability by reducing interest repayment costs. In the short run, this is likely to encourage firm entry and increase investment in the sector. Even where it is provided on fully commercial terms, public debt finance may confer support by enabling projects that wouldn’t otherwise have been funded on capital markets. There are several market failures or barriers that may restrict investment flows to the sector (see below), and public finance addresses some of these by demonstrating the commercial viability of a new business model or technology. In the longer run, this “proof of concept” lowers the risk profile of similar projects and facilitates private investment.

140. The International Solid Waste Association (IWSA) identifies a shortage of investment funds as a key barrier to higher material recovery and recycling rates (IWSA, 2015). Sub-optimal investment flows to the secondary sector may result from several factors. Most obviously, capital, natural resource, energy, water, and waste disposal prices which do not fully reflect their true social costs tend to disproportionately favour primary metals firms. As outlined in Chapter 3, the primary metal production process uses these inputs relatively intensively, and policies which reduce their respective market prices probably serve to decrease the relative profitability of material recycling and re-processing projects.

⁷ Comment received from Environment and Climate Change Canada.

141. Investment shortages may also result from specific characteristics of the secondary metal business model. For example, certain aspects of the secondary production process may be comparatively novel with respect to those in the primary process. This is particularly relevant for the upgrade phase of secondary production; mechanised sorting technology utilising the differing physical properties of particular waste products are still relatively immature. The additional investment risk associated with any such new or relatively unproven technology can make financing difficult. In addition, geographic separation may make transportation of end of life metallic products between urban centers economically unattractive relative to a network of smaller sorting facilities (EC, 2015). This can generate financing difficulties in situations where private capital seeks investment opportunities of a certain size. Finally, the volatility of scrap metal prices (Blomberg and Soderholm, 2009) introduces additional uncertainty in expected project returns, and can therefore deter investment in secondary sorting or reprocessing capacity.

4.3.1.1 Debt finance

142. Public debt finance for projects in the secondary metal sector tends to be channelled through a range of financial institutions which share the common characteristic of being capitalised (initially at least) with public funds. Examples include national development banks (e.g., Germany’s KfW bank group), green investment banks (e.g., the UK’s Green Investment Bank), and other types of regional or national level investment bank (e.g., the European Investment Bank).

143. The recent advent of green bonds has increased the amount of investment capital available to these financial institutions. Green bond issuance amounted to USD 36.6 billion in 2014 and USD 40 billion in 2015 (OECD, 2015c), and around half of this was issued by sovereign national or supranational banks, agencies, and institutions (Figure 13). EIB issuances in the first four months of 2016 alone amounted to EUR 2.8 billion (Climate Bonds Initiative, 2016). Although the majority of funds raised by green bonds are earmarked for climate or low-carbon related investments, a proportion may also be available for recycling projects. Notably, the first recycling dedicated bond (EUR 380 million) was issued by French recycling firm Paprec in 2015 (Climate Bonds Initiative, 2015).

Figure 13. Green bond issuance by source between 2007 and 2015

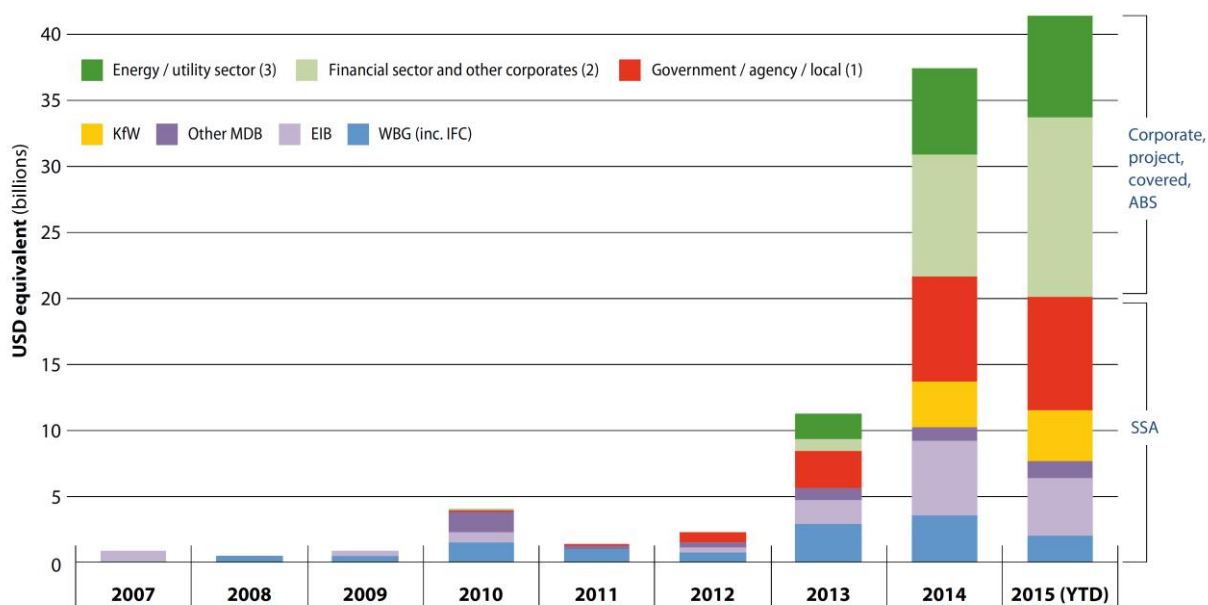

Note: SSA: Sub-sovereign, Supranational and Agency, Muni: Municipal; ABS: Asset Backed Securities. (1) includes national development banks, sub-sovereign jurisdictions including municipalities, agencies, and local funding authorities. (2) includes financial sector bonds and all other corporates that are not energy/utility sector, as well as covered, project and ABS not energy/utility related. (3) includes corporate bonds issued by energy/utility companies as well as covered, project and ABS related to energy/utility companies

Source: OECD (2015c), Green bonds: mobilising the debt capital markets for a low-carbon transition

144. Within the EU, the European Investment Bank (EIB) Group administers a number of lending programs which are potentially available to firms in the European secondary metals sector. The European Fund for Strategic Investment (EFSI), which was launched in mid-2015, identifies the circular economy as one of several key lending objectives (EIB, 2015). The fund had an initial capitalisation of EUR 61 billion (EIB, 2016), which is used to provide debt finance, equity finance, and loan guarantees with the intention of triggering additional third party investment. As of May 2016, the EIB had lent EUR 12.8 billion, of which 9% went to firms in the ‘environment and resource efficiency sector (EC, 2016). It is unclear what proportion of this accrued to secondary metal firms.

145. The European Investment Bank also manages InnovFin, an EU initiative intended to facilitate access to finance for innovative firms and other entities within Europe (EIB, 2016). The program is expected to make around EUR 24 billion of debt and equity financing available to eligible sectors by 2020. Secondary metal recycling and smelting firms are eligible under the climate action, environment, resource efficiency, and raw materials banner. However, it is again unclear what proportion of loanable funds will accrue to metal firms, let alone those in the secondary sector; many of the raw material specific lending requirements appear to target sustainable or innovative mining technologies.

146. Public green investment banks (GIB’s) are a relatively new phenomenon (OECD, 2016d), but also offer finance for material recovery and recycling projects. GIB’s are differentiated from public infrastructure funds and other grant making public institutions by their commercial character; debt finance is provided on commercial or near commercial terms. Green investment banks are also different to public investment banks or their international equivalents; the investment focus is exclusively on environmentally related projects. As of December 2015, the OECD had documented thirteen national or sub-national examples of such banks OECD, 2015. The investment focus for many of these institutions was carbon or climate related, but several had also lent to waste management and recycling projects. In the UK, the Green Investment Bank has at least two relevant funds. The Recycling and Waste Fund was created in 2015 with an initial capitalisation of £50 million targeting “smaller-scale recycling and waste projects across the UK” (GIB, 2016). The Waste Resources and Energy Fund was created in 2012 and has financed material recovery facilities, although most funds were directed towards waste to energy plants (GIB, 2016).

4.3.2 Foregone tax revenues

147. Material sorting, recycling, and reprocessing firms are eligible for tax rate reductions, targeted deductions or credits, or special exemptions in a number of countries. These provisions are mostly provided through corporate income tax, although targeted value added tax (VAT) relief is also available in some cases. In addition, environmentally related taxation targeting the by-product “bads” associated with metal production may increase the relative competitiveness of firms in the secondary sector. Although green taxes do not necessarily represent support, they serve to decrease the cost of inputs used relatively intensively in secondary metal production (e.g., scrap) while increasing the cost of inputs used relatively intensively in primary production (e.g., energy).

4.3.2.1 Corporate income tax (CIT) provisions

148. Firms in the secondary metal sector do not benefit from CIT rate reductions or tax holidays to the same extent that mining firms do. No targeted rate reductions are known for recycling firms, although they probably benefit disproportionately (relative to the mining industry) from the availability of reduced CIT rates for small businesses. This is especially the case for commercial scrap collectors, which operate at the top of the scrap metal supply chain; their size is often limited by the flow of end of life scrap from nearby

population or industrial centres. Preferential small and medium enterprise corporate income tax rates are available in a range of countries including Australia, Japan, the Netherlands, and Spain (OECD, 2016c).

149. Corporate tax paid by recycling firms is also a function of what definition of earnings is applied. The tax code in many countries allows firms to reduce their taxable income – their tax base – by deducting costs above and beyond what would normally be considered normal business expenses. In the context of the secondary metals industry, the most important provisions relate to tax credits on the value of scrap feedstock, and to accelerated depreciation rules targeted at recycling specific assets. Again, relative to the primary sector, the number of countries applying these provisions is limited.

150. Recycling specific tax credits are available to secondary metal firms in several jurisdictions (KPMG, 2013). Mexico City grants a tax credit to corporations that recycle or reprocess their solid waste. The credits are offered on a sliding scale, from 20% of payroll tax for firms which reprocess between 33% and 44% of their waste, up to 40% for firms which recycle or reprocess more than 60% of their waste. A similar scenario exists in Brazil – secondary metal firms benefit from tax credits on the value of scrap or other intermediate metal feedstock.

151. The OECD database of environmental taxation measures indicates that targeted accelerated depreciation provisions for recycling facilities are available, or potentially available, in France, Ireland, Japan, Netherlands, and the US (OECD, 2016b). For example, the RISE program in the US entitles domestic recycling firms to write-off 50% of an assets value for tax purposes in the first year of operation (KPMG, 2013). It was enacted in 2008 and was extended under the PATH act of 2015. Accelerated depreciation provisions improve project profitability by reducing the assessable tax base early in a project's life.

4.3.2.2 *Value Added Taxes*

152. A number of countries provide support for firms in the secondary metal sector through value added taxes (VAT). The most common provision relates to the input tax portion of VAT; recycling firms which acquire metal scrap from VAT exempt or non-registered entities are entitled to claim a deemed input VAT credit. This credit can then be used to reduce the output tax portion of the VAT the firm is required to pay on behalf of its clients. Deemed input VAT tax credits are particularly important for scrap dealers situated at the top of the secondary metal supply chain. These firms often acquire scrap from VAT non-registered entities such as individuals or publicly owned and operated municipal waste collection organisations. Countries where deemed input VAT tax credits are available include South Korea (KPMG, 2013), South Africa (Saica, 2004), and the United States (IWSA, 2014).

153. VAT-related tax relief is also available for recycling firms in China through targeted partial VAT rebates (KPMG, 2013). Rebate rates vary between 30% and 100% depending on the commodity, but are set at 30% for ferrous scrap.

4.3.3 *Induced transfers*

154. Certain waste management policies – landfill taxes and bans, the public provision of separated recycling collection, and EPR requirements among others – divert waste flows away from landfilling and incineration, thereby increasing the quality and availability of scrap feedstock. In many countries, where trade restrictions limit cross border shipments of potentially hazardous materials, this can lead to downward pressure on domestic scrap prices which, in turn, induces a transfer to the secondary metal sector. The easing of pre-existing feedstock supply constraints may generate additional benefits as secondary firms begin to operate at a larger scale.

155. Quantifying the monetary value of induced transfers is difficult, and presents a key barrier to comparing the magnitude of primary and secondary support. In particular, there is often a difference between the net cost of the measure for governments, and the net benefits of the measure for recipients. In the case of landfill taxes, the net cost for governments is actually negative (taxes generate revenues) while the net benefits conferred to recycling firms is difficult to quantify; it depends on how the tax translates into feedstock prices.

156. The regulations that set up induced transfers for the secondary sector are commonly targeted at the MSW stream. In terms of metal, MSW contains considerable potential value even though the absolute amount of contained metal is small relative to that in C&I or C&D waste⁸. Much of the metallic content is in the form of steel or aluminium packaging, which is both homogenous and composed of relatively simple alloys. Furthermore, the MSW stream is an important source of high value metals and alloys; household appliances and personal electronics contain considerable copper along with a range of other precious and rare elements.

4.3.3.1 Landfill taxes

157. The use of landfill or incineration taxes has become increasingly widespread in OECD countries during the last decade. They are generally assessed by weight, and the relevant tax rate varies across different materials and across sub-national boundaries. Internationally, there is considerable variation in landfill tax rates (Figure 14). From an economic perspective, disposal taxes are broadly justified by pollution externalities. Landfilled waste can produce methane emissions or toxic liquid leachates while incineration may result in local atmospheric pollution. In practice, disposal taxes are often intended to serve other objectives, such as ensuring that public waste management services are fully cost covering; they may not reflect the magnitude of marginal environmental damages.

Figure 14. Landfill tax rates in OECD countries in 2013

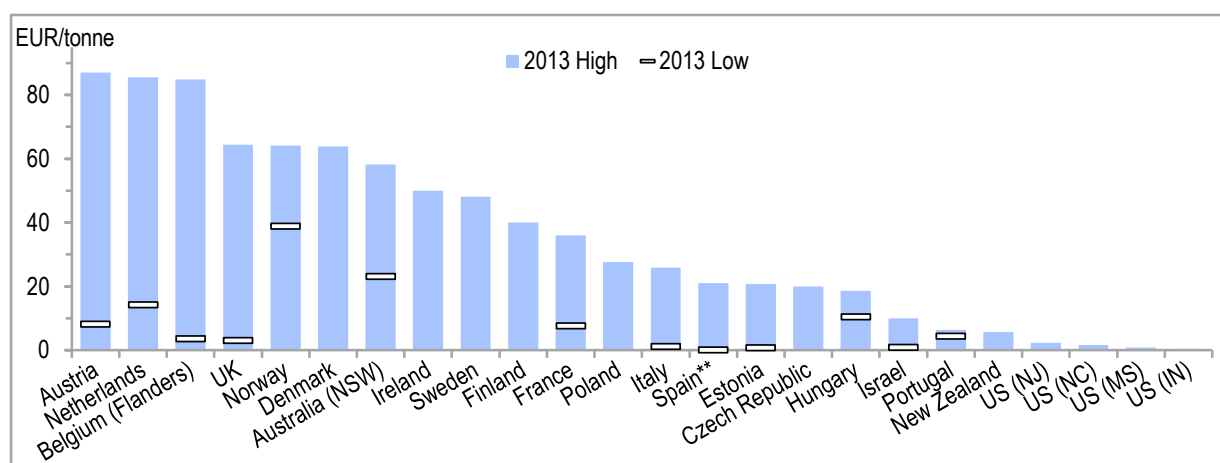

Source: OECD (2016b), Environmental Policy Instruments Database

158. Landfill bans on specific materials also exist in a number of countries. In the US, twenty states have banned the disposal of any form of e-waste (Electronic Recyclers International, 2016) while several European countries ban the disposal of waste with a certain organic content (CEWEP, 2012). Switzerland has had a landfill ban in place for municipal solid waste since 2005; all material not recycled is incinerated.

⁸ As highlighted in Chapter 1, available data suggests that metal accounts for only around 5% of the weight of MSW.

Six other European countries – Austria, Denmark, Germany, the Netherlands, Norway, and Sweden – have landfill bans on certain products (Zerowaste Europe, 2015). In addition, the EU Action Plan for a Circular Economy currently under discussion proposes a ban on landfilling of separately collected waste (EC, 2016).

159. Landfill and incineration taxes or bans discourage waste disposal, which serves to divert the flow of waste towards recovery and recycling activities. This induces a transfer for metal recycling and reprocessing firms which benefit from eased feedstock supply constraints or lower feedstock prices.

160. The value conferred by landfill taxes and bans is difficult to quantify, but to a large extent depends on the availability of other disposal options. Under certain conditions, such as where illegal dumping or incineration is cost effective relative to recycling, the creation of landfill bans or taxes may actually serve to reduce the flow of waste towards the secondary sector. One key result from the theoretical literature is that landfill taxes that do not fully reflect the external cost of disposal may be preferable in situations where illegal dumping is feasible (Fullerton and Kinnaman, 1995). In the European context, several recycling industry lobby groups have expressed reservations about proposed landfill bans (in the EU Action Plan for a Circular Economy). The key concern is that such policies may have unintended and undesirable consequences like increased investment in incineration facilities (Zerowaste Europe, 2015).

161. Finally, landfill taxes on MSW may be ineffective in creating incentives for metal capture. Kerbside waste and recycling collection is provided by local governments, and which facility (material recovery, landfill or incineration) each material type is directed to is generally pre-determined. Landfill taxes are incident upon households and businesses, but do little to incentivise better material sorting when they form part of an annual flat-rate charge (as is often the case currently – see the discussion of municipal waste in section 4.3.3.2). Landfill taxes and bans may be more relevant for the commercial or industrial and construction or demolition waste streams, where firms directly face the cost of waste disposal.

4.3.3.2 Public provision of separate recycling services

162. Local governments in many jurisdictions are required by national or sub-national legislation to organise the collection and disposal of municipal solid waste. These laws generally specify a set of minimum standards for public waste management, and there is often a requirement for the separate collection of one or more recyclables. In the EU, the Waste Framework Directive requires that, under certain conditions, separated collection of paper, plastic, glass, and metal is provided by 2015. In the United States, disposal bans on certain recyclable materials exist in many states (NERC, 2011).

163. The public provision of separate recycling collection by local government increases the supply and quality of secondary scrap feedstock. Metallic waste that would otherwise be mixed with general household and business refuse, and which would therefore require additional sorting, is already ‘clean’ upon collection. In some cases, such as for aluminium cans, this means that secondary scrap can be recycled without the need for an intermediate upgrade phase. In other cases, such as where several recyclable fractions are collected together, the limited number of products contained in the waste stream greatly simplifies automated material upgrading. In sum, costs associated with material sorting are reduced for recyclers.

164. Again, the transfer generated for secondary producers is difficult to quantify, and will vary according to whether the net cost of separated recycling collection (for local government) or the net benefits (for recycling firms) is considered. The two numbers generally diverge because a significant proportion of the value contained in clean metal scrap originates not from the provision of separate collection, but from the sorting effort provided by households and small businesses.

165. In practice, the difference between the net cost of service provision and the net benefits conferred through lower scrap prices will depend on how local governments structure waste management services and contracts. For example, if local governments operate waste collection services themselves, and require only that these services be cost-covering, then the benefits conferred to the secondary sector will be greater than the net cost of provision (which would be zero). It is difficult to establish the net cost of a particular local government's separated recycling collection program. This service is often physically undertaken using the same machinery used for general waste collection, and the additional cost of recycling collection may not be disaggregated in public accounts. In addition, although revenues generated by the sale of collected recyclables are usually available, the degree to which recyclables collection is funded by the waste management portion of local taxes is often unclear.

4.3.3.3 *Extended Producer Responsibility: product take-back regulations*

166. Product take-back is a particular variety of EPR which requires product manufacturers or importers to re-assume some responsibility for their products at the end of their life. This can mean taking physical charge of products through the provision of drop-off locations allowing product return, or taking economic responsibility for the management of end of life products by third party firms. Take-back requirements target a broad range of consumer products and are relevant for the secondary metals sector. Common examples include household appliances and personal electronic devices, all of which are traditionally processed via the municipal-solid-waste system. They may also apply to certain consumer products that are processed beyond the MSW route; end of life vehicles are one such example. Data from the OECD indicate that take-back requirements have grown rapidly during recent decades; they now represent around three quarters of the EPR schemes in existence (OECD, 2016e).

167. When they are well designed, take-back requirements can stimulate additional secondary feedstock supply in a similar way to landfill taxes and the provision of separated recycling. In the short run, and assuming that illegal dumping is not feasible, firms face a choice between product recycling and disposal; theory suggests they will opt for the management option which entails the least cost. The extent to which take-back requirements increase scrap supply depends significantly on the cost of waste disposal in the relevant jurisdiction. Take-back is likely to be less effective where low cost landfill or incineration services are available; producers face little additional cost and simply choose to bury or burn end of life products. Regulators have attempted to address this issue in two ways. One approach is to marry take back requirements with mandated recycling requirements. A second approach is to ensure that per-unit landfill or incineration charges fully reflect the social cost of waste disposal. This includes the economic cost of constructing and operating waste facilities along with relevant external costs such as leachate contamination of groundwater or methane loss to the atmosphere.

168. In the long run, take back requirements can also create incentives for firms to design products that either contain less material (and are therefore less costly to dispose of) or are less complex (and are therefore more amenable to dismantling and eventual recycling).

5. TRADE RESTRICTIONS ON MINERAL ORES, SCRAP, AND METALS

5.1 Introduction

169. Trade restrictions affecting mineral ores, scrap, and metals can distort competition between primary and secondary metal producers in a similar way to the measures discussed in Chapters 3 and 4. Import restrictions – tariffs or other non-tariff import barriers – can confer support for domestic producers by reducing market access for foreign producers. Export restrictions – taxes, quotas, or bans – increase the domestic supply of the targeted good, with potentially lower prices for domestic firms situated downstream. Both measures can be seen as a form of induced transfer; lower costs for domestic firms enhance their competitiveness relative to foreign counterparts. More generally, the interconnected character of global metal value chains means that support conferred in one jurisdiction may be conveyed globally through trade. This is particularly relevant in the metals sector because of the strong geographic concentration of virgin and anthropogenic metal stocks. Few countries are naturally endowed with the full array of metal resources, and those that are continue to import a range of specific finished metal products.

170. There are three sections in this chapter. The first describes trade flows of primary and secondary materials; it builds on the discussion of global metal production patterns in Chapter 1. The second section draws heavily on the OECD Inventory of Restrictions on Exports of Industrial Raw Materials to highlight the various types of trade restrictions that are currently imposed by different countries. The focus here is on export restrictions, partly because these are relatively widespread and binding in the industrial raw materials sector (OECD, 2014), but also because the highly concentrated nature of global metal supply means they can have significant international impacts when applied by certain countries. The third section provides a description of how export restrictions can confer support for metal producers.

171. Four main messages emerge. First, trade flows of primary mineral ores and concentrates increased at a significantly faster rate than those for metal scrap during the last decade. This may partially reflect limited growth in scrap generation, but may also be due to the effect of policies which restrict cross-border shipments of potentially hazardous materials. Second, restrictions on exports of primary mineral ores, metal scrap and waste, and finished metals are applied by a significant number of countries. This probably partly reflects the fact that WTO disciplines relating to exports are less evolved than those for imports. Third, export restrictions can theoretically increase the competitiveness of domestic downstream producers, who may benefit from reduced feedstock prices. Finally, some of the export restrictions on primary mineral ores and concentrates are applied by countries representing a large share of global supply. Brazil, China, and Indonesia currently apply significant restrictions on exports of certain commodities. This is important because global commodity prices are more likely to be affected in such cases; a restriction applied by one country may therefore influence the competitiveness of primary and secondary metal production in other jurisdictions.

5.2 Trade in mineral ores, scrap, and metals: some stylistic facts

5.2.1 *Primary and secondary metal exports: volumes and trends*

172. Around 1,550 million tonnes, or USD 132 billion, of primary ores and concentrates were exported in 2015 (UN COMTRADE, 2016). Iron ore was the most important commodity, accounting for 88% and 47% of total upstream exports by weight and value respectively (Table 7). Copper ores and

concentrates and bauxite ores were also important in value terms, representing 29% and 3% of exports. All other primary metal ores account for only 20% of the value of primary exports; ores of zinc (6%), lead (4%), and precious metals (gold, silver, and platinum group) (4%) are the most important of these.

173. The importance of trade in upstream raw materials is made apparent by a comparison between production (USGS) and trade (UN COMTRADE) data. For iron ore, for which these two datasets are broadly comparable, around 43% of 2013 mine production was exported outside the country of origin. The equivalent figure for other metals is difficult to establish, but likely to be at least as large because China, the world's largest iron ore producer, exports very little of its domestic production.

174. Exports of metal scrap and waste amounted to USD 76 billion in 2015, around half the size of primary exports in value terms. It is unclear what proportion of annual scrap production this represents; reliable data on this is unavailable. Scrap metal exports represented ~58% of the total value of primary upstream exports, but only 6% of the total weight. This implies significantly higher upstream secondary material prices for some metals. For example, aluminium scrap prices were more than an order of magnitude higher than those for bauxite (primary aluminium ore) in 2015. This partly reflects the relatively low per-unit aluminium content of bauxite, but also the relatively high downstream costs of extracting it.

175. Finally, secondary metal trade is dominated by precious metals, aluminium, copper, and steel. All other secondary metals account for only 19% of the value of secondary exports; magnesium (2%), cobalt (2%), tantalum (1%), and manganese (1%) are the most important.

Table 7. Global trade in metals for 2015

	Fe			Al			Cu			Total	
	Weight	Value	Implied price	Weight	Value	Implied price	Weight	Value	Implied price	Weight	Value
	Mt	USD billion	USD/t	Mt	USD billion	USD/t	Mt	USD billion	USD/t	Mt	USD billion
Ores and concentrates	1,358	62	45	88	3	31	17	38	2,289	1,547	132
Scrap	81	25	312	7	10	1,392	6	14	2,493	98	76
Finished metals		276			105			141			843

Source: UN COMTRADE (2016), UN COMTRADE Database

176. Figures 15 and 16 track the evolution of upstream primary (ores and concentrates) and secondary (metal wastes and scrap) exports by weight and value respectively. Between 2000 and 2014, it's clear that the volume of primary material exports increased at a faster rate than that for secondary metal scrap exports. For iron ore, this increase in exports closely tracks production levels (USGS); both increased by a factor of about 2.9 over this period. The nominal value of primary exports also increased at a faster rate than that for secondary exports. Taken together, the trade data indicate a relatively consistent world primary – secondary price ratio; implied prices of both increased by a factor of about 2.7 between 2000 and 2014, although this may mask more nuanced trends for individual metals.

177. Slower growth of metal waste and scrap exports may reflect several factors. Firstly, new sources of metal scrap are limited in a way that new sources of virgin materials aren't; slow growth in metal scrap trade may reflect constraints on the flow of EOL goods and materials from in-use stocks. Alternatively, this trend may come from higher ratios of domestic scrap consumption, possibly due to export restrictions (see Section 5.3).

Figure 15. The evolution of upstream primary and secondary material exports by weight

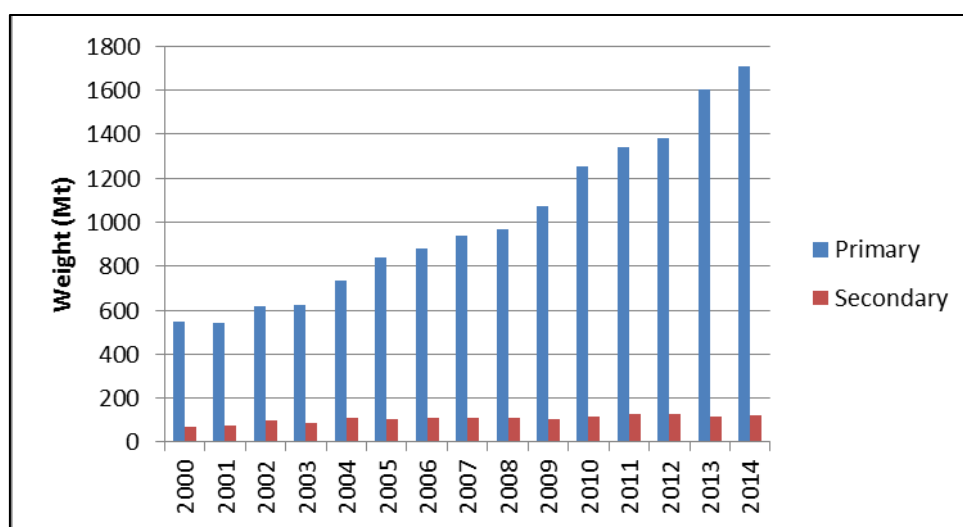

Source: UN COMTRADE (2016), UN COMTRADE Database

Figure 16. The evolution of upstream primary and secondary material exports by nominal value

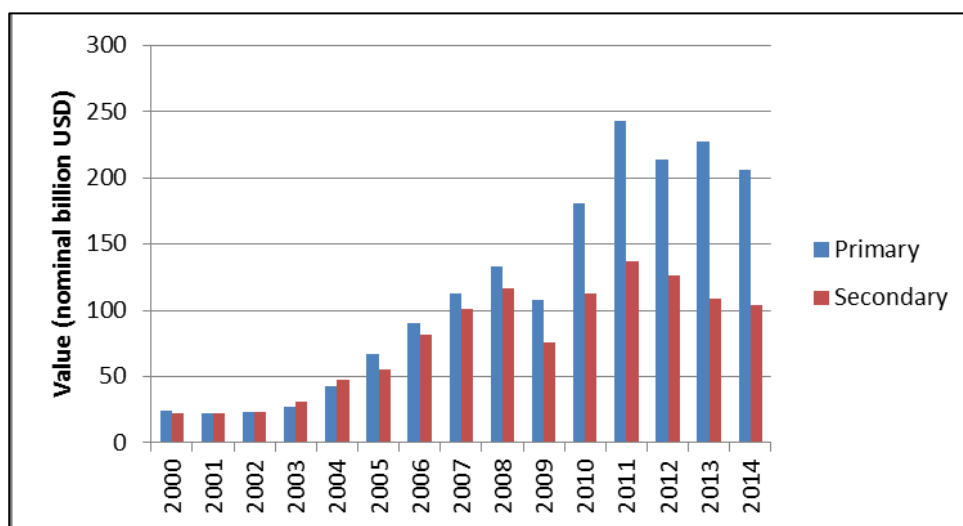

Source: UN COMTRADE (2016), UN COMTRADE Database

5.2.2 Primary and secondary metal exports: country and commodity breakdown

178. Figure 17 shows the top five exporters of mineral ores, metal scrap, and finished metals for iron, aluminium, and copper. Exports of most mineral ores and concentrates are dominated by a handful of countries, mostly those endowed with virgin mineral resources. For both iron ore and bauxite, five

countries are responsible for ~95% of total exports by value. Australia and Brazil are the largest exporters of both commodities; Malaysia, Guinea, and India are major exporters of bauxite. Copper ore and concentrate exports are slightly less concentrated, with the largest five exporters – Chile, Peru, Australia, Canada, and the United States – accounting for 80% of total value.

Figure 17. Top five exporters of primary iron ore, bauxite, and copper ore (left), steel, aluminium, and copper scrap (middle), and finished steel, aluminium, and copper metal (right)

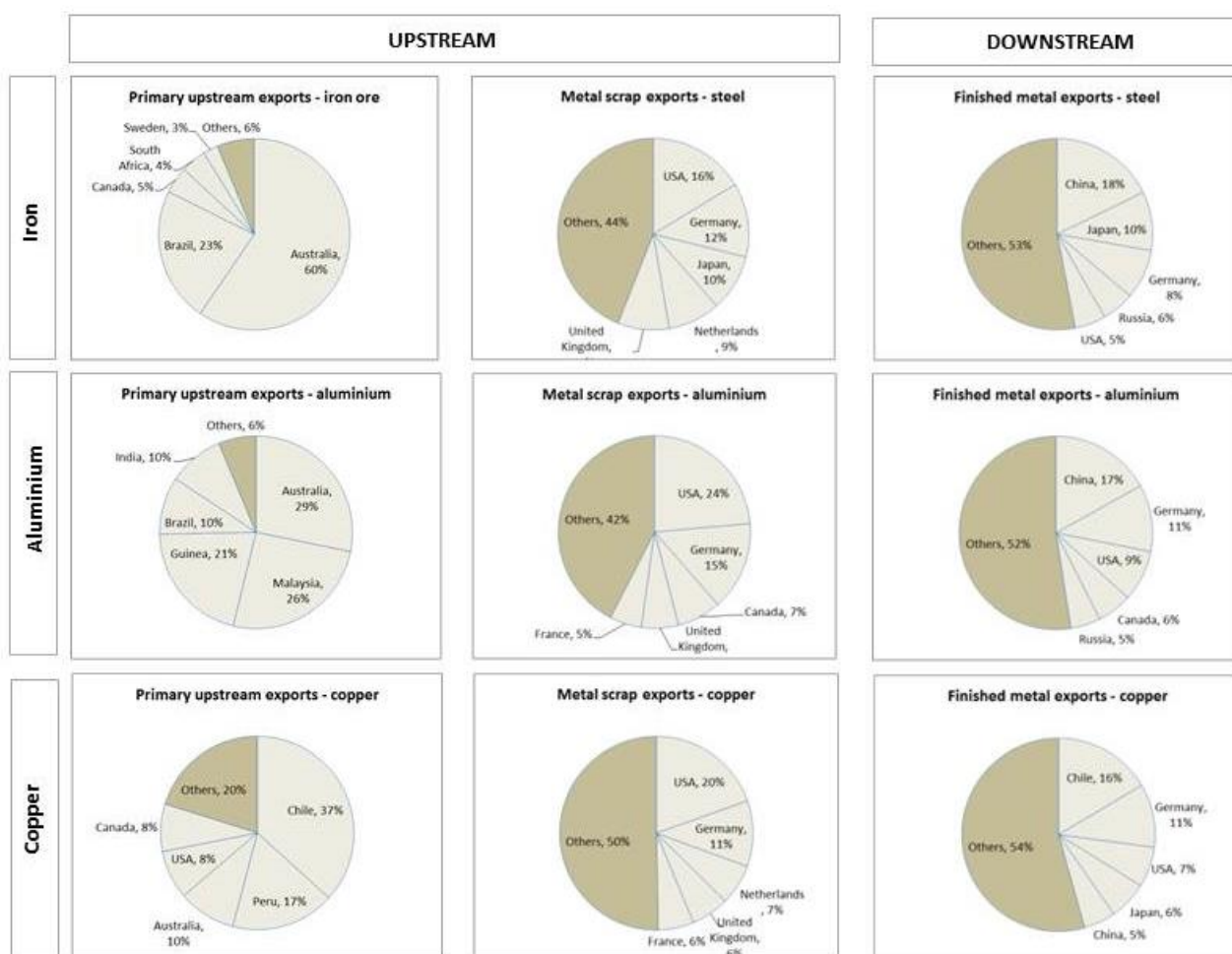

Source: UN COMTRADE (2016), UN COMTRADE Database

179. Other metals for which the production and export of primary ores and concentrates are heavily concentrated include antimony, chromium, cobalt, natural graphite, nickel, niobium, tungsten, and the suite of rare earth elements. Many of these have been identified as ‘critical minerals’ on the basis of current and future potential supply risk (Coulomb et al. 2015). In 2015, South Africa accounted for 82% and 71% of global cobalt and chromium exports respectively (UN COMTRADE, 2016). Around 70% of tungsten exports (Canada, Russia, Bolivia, and Spain) and nickel exports (Philippines, Australia, USA, and Zimbabwe) originated in four countries. Disaggregated trade data is not available for antimony, chromium, niobium, tantalum, and the REE’s, however the highly concentrated character of mine production suggests exports are dominated by a small number of countries. In 2013, China accounted for 75% and 87% of global antimony and REE mine production (USGS, 2016). In the same year, 90% of

global niobium extraction took place in Brazil, and 67% of tantalum extraction in the Rwanda and the DRC.

180. Exports of metal waste and scrap are less concentrated than those for primary minerals and concentrates; the largest five scrap exporters account for around 50% of total exports by weight. The key exporters are big industrialised nations where high levels of historic capital accumulation and current consumption result in large present-day domestic scrap metal flows. Canada, France, Germany, Japan, the Netherlands, the United Kingdom, and the United States are the largest exporters of most scrap metals by value.

181. The geographic distribution of finished metal exports is broadly similar to the distribution of production discussed in Chapter 1. Canada, China, Germany, Japan, Russia, and the United States have considerable domestic smelting and refining capacity and are net exporters of most finished metals. Final metal production often utilises significant quantities of imported feedstock; China, Germany, and Japan are large importers of semi-processed iron, aluminium, and copper ores. On the secondary side, China, Germany, and India are important importers of most metal scraps (Figure 18).

Figure 18. Top five importers of primary iron ore, bauxite, and copper ore (left), and steel, aluminium, and copper scrap (right)

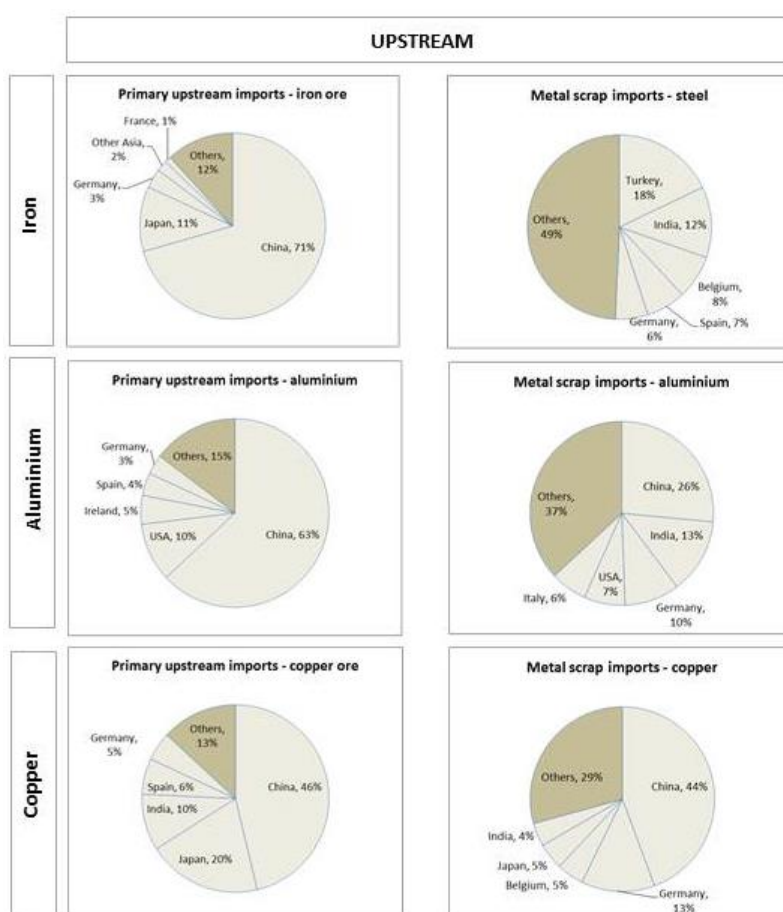

Source: UN COMTRADE (2016), UN COMTRADE Database

5.3 Export restrictions

182. Restrictions on the export of mineral ores or concentrates and metal waste or scrap exist in a number of countries. The OECD Inventory on Export Restrictions on Industrial Raw Materials (OECD, 2016f) assessed 44 important producer countries and found that 24 had some restriction on the export of primary mineral ores, 29 on the export of metal scrap and waste, and 25 on finished metals or products.

183. Table 8 classifies export restrictions in place in 2014 by measure. There are two apparent patterns. First, there are many more measures affecting metal waste and scrap trade than that for metal ores and concentrates. This is largely because countries which impose restrictions on secondary materials do so across a wider range of commodities than countries imposing restrictions on primary materials. Second, export taxes and licencing requirements are the most common measures used to restrict the export of all three types of material. Export bans and quotas are less commonly used, but represent important export restrictions in several key countries (see below).

Table 8. Number of countries applying export restrictions: by measure in 2014

	Metal ores and concentrates	Metal waste and scrap	Finished metals
Export Ban	10	97	19
Export Quota	4	15	14
Export Tax	72	265	309
Licencing Requirement	60	209	215
Other restriction	27	43	213
Total	173	629	770

Source: OECD (2016f), OECD Inventory on Export Restrictions

184. Table 9 classifies export restrictions in place in 2014 by which commodity they apply to. At the aggregate global level, there is no particularly commodity focus for export restrictions on primary materials. The same is not true for secondary materials where around one third of documented export restrictions apply to steel scrap.

Table 9. Export restrictions by metal in 2014

	Metal ores and concentrates	Metal waste and scrap
Aluminium	7	32
Chromium	8	21
Cobalt	13	21
Copper	18	32
Iron	10	208
Tin	12	24
Titanium	11	21
Tungsten	7	24
Others	87	246
Total	173	629

Source: OECD (2016f), OECD Inventory on Export Restrictions

185. The number of export restrictions relating to industrial raw materials increased rapidly between 2006 and 2012 (Figure 19), a period characterised by rapidly increasing emerging markets demand for metals. This provides some indication of one motivation behind the creation of many of these measures; as global demand for materials increases, concerns about domestic resource scarcity and resource security also rise. Export restrictions allow governments to conserve mineral resources for domestic consumption. A desire to encourage investment in domestic downstream metal processing facilities may also be an important motivation for certain governments.

Figure 19. Year of introduction of export restrictions present in 2012

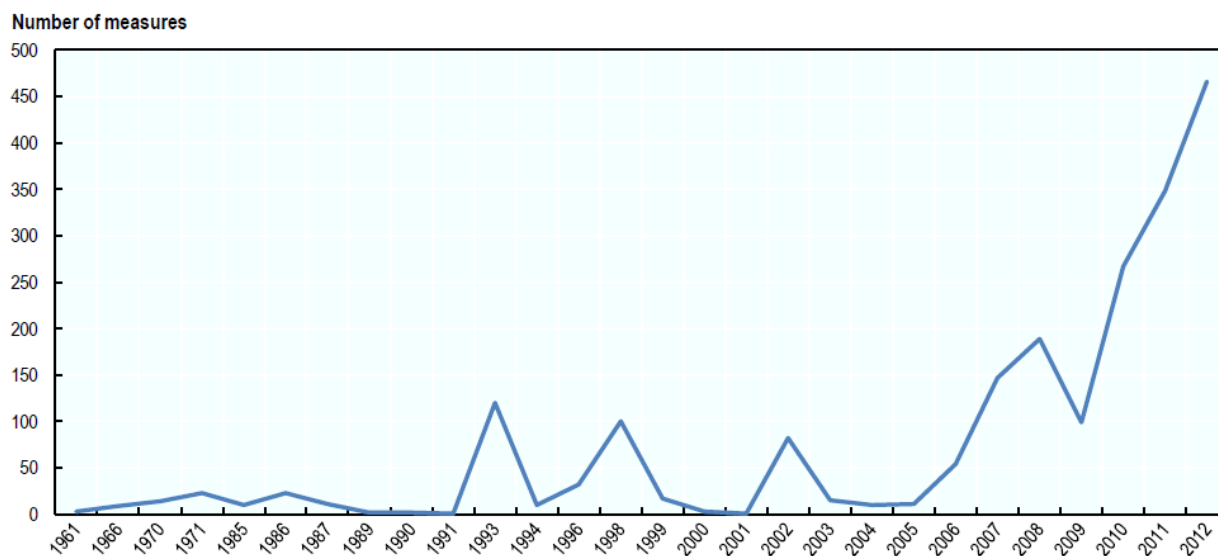

Source: OECD (2014), Export Restrictions in Raw Materials Trade

186. Export restrictions affecting upstream primary and secondary feedstock can confer support for domestic downstream sectors. Increased domestic supply puts downward pressure on the price of the targeted product, thereby reducing costs for domestic firms which use it as an intermediate input. In addition, when they are imposed by large exporting countries, export restrictions may place upward pressure on international prices of the targeted good. This increases the cost of intermediate inputs for international downstream firms, thereby increasing the competitiveness of their counterparts in the country imposing the restriction.

187. This section will focus primarily on upstream export restrictions affecting mineral ores and metal scraps. Attention is given primarily to quantitative export restrictions such as taxes, quotas, and bans; other forms of export restriction are addressed in detail in the OECD Export Restrictions database.

5.3.2 *Export restrictions on primary minerals and concentrates*

188. There were 173 documented restrictions affecting the export of primary minerals and concentrates in 2014. Around 60% of these measures are accounted for by five important mining countries: China, the DRC, India, Indonesia, and Russia. Other significant mineral exporting countries applying one or more primary export restriction include Argentina, Brazil, Guinea, Malaysia, the Philippines, Rwanda, South Africa, and Zambia.

5.3.2.1 *Export taxes*

189. Export taxes represented ~40% of primary export restrictions in 2014. The most noteworthy measures are in China, where export tax rates of between 10% and 30% are applied to materials for which China has a very large share of global production. For example, China accounts for 97%, 84% and 37% of global upstream rare earth, tungsten and tin production (USGS, 2016), and levies ad-valorem taxes of 20% to 25% on exports of these commodities.

190. High export tax rates levied in other countries may not distort global prices to the same degree because they affect a smaller share of world trade. These measures nevertheless have important domestic consequences because they place considerable downward pressure on domestic commodity prices. India applies a tax of 30% on iron ore exports, Indonesia a tax of up to 25% on copper concentrate exports, and Zambia a tax of 10% on exports of copper and cobalt ores or concentrates.

191. Low export tax rates in Guinea (0.075%) and the Democratic Republic of the Congo (1%) are noteworthy because they are applied to materials for which these countries represent a very large share of global production and exports. Even slight tax rate increases could lead to significant movements in the relevant global prices. Guinea accounts for 21% of all global bauxite exports. Trade data is poor for the DRC, but it accounts for 49% and 17% of global cobalt and tantalum mine production respectively (USGS, 2016)

5.3.2.2 *Export quotas*

192. Brazil and China applied quotas to restrict the export of several materials in 2014. The Brazilian quota applied to ores and concentrates of niobium and tantalum, commodities for which Brazil accounted for 90% and 13% of global production respectively (USGS, 2016). It is unclear how binding the quota is. The Chinese quota applied to ores and concentrates of tin, tungsten, molybdenum, and various rare earth elements, materials for which China holds a significant share of global upstream production. The Chinese quota system was abolished in mid-2015 following a WTO ruling.

5.3.2.3 *Export bans*

193. Indonesia prohibited the export of unprocessed copper, nickel, cobalt, aluminium, and precious metal mineral ores in 2014. The restrictions on aluminium and nickel are especially noteworthy because Indonesia accounts for 20% and 31% of global mine production of these metals (USGS, 2016). Zimbabwe also had an export prohibition on unprocessed chromium exports, but this was lifted in mid-2015.

5.3.3 *Export restrictions on secondary scrap and wastes*

194. There were 629 documented restrictions affecting exports of metal waste and scrap in 2014. The majority of these are applied by emerging economies; one key distinction with respect to the primary sector is that restrictions are not imposed by large scrap producing or exporting countries. Production data is unavailable for secondary metals, but UN COMTRADE data indicates that 80% of metal waste and scrap exports by value originate in Canada, the EU-28, Japan, or the US – none of which apply any quantitative export restrictions directly to metals⁹. As such, the impact of secondary export restrictions is likely to be largely limited to domestic markets, where downstream secondary metal processing firms may benefit from lower scrap metal prices.

⁹ However, restrictions on the export of end of life products containing significant amounts of metal exist in some of these countries. For example, the EU Directive on End of Life Vehicles restricts exports of these products beyond the EU

5.3.2.1 Export taxes

195. Export taxes represented ~42% of secondary export restrictions in 2014. Export tax rates on secondary materials are highest in China, where a rate of 40% is applied to various types of steel scrap, and Russia, where a rate of 40% is applied to copper and aluminium scrap.

196. The average export tax rate on secondary materials across all countries is ~14%, which is very similar to the equivalent figure for primary materials. Few countries apply export taxes to both primary and secondary materials, and there is no obvious pattern of favourable tax treatment in those that do. China and Russia have significantly higher rates for metal waste and scrap, whereas India has higher rates for mineral ores and concentrates.

5.3.2.2 Export quotas

197. Only China and Belarus applied export quotas on metal waste and scrap in 2014. They are applied to scrap of a range of metals including various forms of steel, aluminium, copper, and tungsten. It is unclear how binding these quotas are.

5.3.2.3 Export bans

198. Metal waste and scrap export bans documented in the OECD export restrictions database are restricted to several African countries: Burundi, Ghana, Kenya, Nigeria, and Rwanda. However, export bans targeting end of life consumer products may limit scrap metal trade in other countries. Under European waste regulation, end of life vehicles and certain types of electronic waste are considered to be hazardous waste, and export beyond EU-28 borders is prohibited. This effectively represents an export ban on certain scrap; ELV's are an important source of secondary steel while electronic waste often contains an array of high value metals used in circuitry and batteries.

5.3.4 Effects of export restrictions

199. Export restrictions generally serve to increase domestic supply of the targeted product, which in turn places downward pressure on relevant domestic market prices. In the context of the metals industry, restrictions on exports of primary or secondary raw materials induce a transfer from upstream mining and recycling firms, which face lower output prices, to downstream processing firms, which benefit from lower feedstock costs. The magnitude of support conferred to downstream firms depends largely on the intensity of the tax or quota applied, and the elasticity of downstream feedstock demand. Downstream firms that have spare production capacity or that can adjust their input mix benefit to a greater extent from export restrictions.

200. Export restrictions on primary mineral ores and concentrates and secondary scrap can affect global commodities markets when they are imposed by countries with large export shares. In the context of the metals industry, the concentration of upstream mineral ore and scrap production in a small number of countries (see Chapter 1) means that exporting countries are often large relative to world markets. The data presented in section 5.3.1 indicate that upstream export restrictions imposed by major exporting nations currently apply mostly to primary metals; export restrictions on metal waste and scrap are generally imposed by small exporting nations.

201. When applied by large countries, export restrictions on mineral ores and concentrates reduce global supply sufficiently to place upward pressure on the international market prices of these products. This may increase the cost of primary feedstock for downstream processors located in third party countries, which in turn serves to improve the competitiveness of equivalent firms in the country imposing the measure. In addition, competition between primary and secondary downstream processors in third party

countries may be affected; smelters using secondary feedstock may become more competitive as primary feedstock prices increase. The magnitude of support conferred to downstream firms depends largely on: (i) the intensity of the tax or quota that is applied; (ii) the concentration of production and exports of the affected product; and (iii) the prevalence of similar restrictions in other countries.

202. The effect of export restrictions vary according to whether they are considered in the short run or long run. In the short run, upstream export restrictions lower the cost of intermediate feedstock inputs and increase output margins for downstream processing firms. In the longer run, restrictions can incentivise investment in downstream processing capacity and thereby affect the relative primary – secondary share of domestic finished metal production. Technological lock-in may be an important by-product of relatively short lived export restrictions. Finally, to the extent that they increase global primary metal prices, primary upstream export restrictions encourage mineral exploration and the development and construction of new mines. One consequence of the Chinese export quota on REE's was increased exploration spending internationally.

203. There are two important caveats relating to the discussion of the support conferred by upstream export restrictions. The first relates to the downward movement in domestic commodity prices as the export restriction binds. Where domestic supply is competitive, this occurs because firms affected by the restriction compete for domestic market share, resulting in a wedge between domestic and international prices. This may not occur to the same extent when domestic supply is dominated by a single, or several, producers; monopolists can continue to charge international prices domestically without being undercut by competitors. The second caveat relates to third party country retaliation in response to the creation of additional export restrictions. The competitiveness gains available in theory to domestic downstream processing firms may not materialise when export restrictions are applied in many countries.

6. POSSIBLE EFFECTS OF SUPPORT FOR METAL PRODUCTION

6.1 Introduction

204. This chapter shifts from identifying different forms of support to describing their likely consequences. It is divided into two parts. The first section focuses on how support distorts competition between firms in the primary and secondary metals sectors. It begins by outlining how a supply side shock (the support measure) in one jurisdiction influences the production decisions of recipient metals firms. It then discusses competition in metals markets and the extent to which modified firm behaviour might translate into primary – secondary market share, both domestically and globally. The second section draws on a number of published life cycle assessments to summarise the environmental consequences of displaced primary (or secondary) production. This discussion is not meant to be exhaustive. Rather, it is intended to highlight the main environmental concerns associated with each stage of the metals life cycle.

205. The share of primary and secondary production on finished metals markets is the key metric used to discuss the impact of differential support throughout this chapter. Direct competition between the two sectors is mostly restricted to this part of the metal value chain; primary and secondary processing facilities produce finished metal products that are perfect, or near perfect substitutes for each other. The environmental impacts of differential support are also reflected in this metric. All else equal, an increased share of primary metal production implies additional resource extraction (mineral ore, fossil fuel energy, and water) with additional generation of associated by-products (greenhouse gases and residual processing wastes).

206. This chapter is not intended to represent a comprehensive welfare analysis. It also offers no conclusion on the overall welfare impact of government support to the metals sector. The provision of support generates a vast array of benefits and costs for agents operating both within and beyond the metals sector. Many of these impacts are situated in the future; investment decisions made today influence future primary – secondary market share, which has a range of intergenerational environmental implications. Although some support measures clearly target market failures and may therefore be welfare enhancing; others appear to be designed to achieve other objectives such as increased foreign direct investment or domestic job creation. In sum, a full cost benefit analysis is well beyond the scope of this study.

207. Three key messages emerge in this chapter. First, empirical studies indicate that primary and secondary metal processing firms respond to support differently. In particular, the long run elasticity of secondary metal supply with respect to input and output prices appears to be lower than in the primary sector. The apparent unresponsiveness of secondary metals firms to support suggests the existence of barriers to entry; constraints on scrap availability and the volatility of scrap prices are often identified as candidates. One immediate implication is that support measures intended to boost secondary production may have a limited impact for those metals which already have high end of life recovery rates.

208. Second, it is clear that metals value chains span national borders. Targeted sector specific support provided in one jurisdiction modifies domestic primary – secondary market share by encouraging additional production in the recipient sector. It may also influence the production decisions of primary and secondary metals firms in third party countries if global intermediate or finished metal prices are affected. Support provided in large metal exporting countries is therefore particularly worthy of attention.

Third, the life cycle environmental consequences of secondary metal production are significantly lower than those for primary production. The secondary process negates the need for mining, thereby eliminating any associated consequences for local biodiversity, and water and soil quality. Producing metal from scrap also requires considerably less energy than doing so from mineral ores; greenhouse gas emissions are thereby reduced. Secondary production results in fewer waste products than the primary equivalent; mining waste rock and process tailings, both of which can be highly toxic when released into the environment, are not generated. Finally, by utilising metals contained in end of life products as feedstock, secondary production negates the need for these to be disposed of in landfills. Given the above, support measures that serve to boost the share of primary output in total metal production are likely to have negative consequences for overall environmental quality.

6.2 Impact of support at the firm level

209. This section focusses on firm responses to the support measures described in Chapters 3, 4, and 5. The discussion recalls that many of the support measures available in the metals sector are incident on either production inputs or enterprise income. Measures directly affecting output returns or the unit cost of consumption are relatively rare. Support measures which are available at different points in the metal production process may to some extent be transmitted along the value chain.

6.2.1 *Measures incident on downstream producers: lowered input prices*

210. Primary metal smelters and secondary re-melters use capital, labour, metal feedstock, and energy to produce finished metal products. Support measures which are directly incident on these inputs for final metal producers include accelerated depreciation provisions on capital investment, targeted exemptions from energy related taxes, and the provision of electricity on concessionary terms by state owned utilities. These measures have two main impacts for recipient firms in the short run. Firstly, without any change in firm behaviour, lower per-unit production costs translate into increased per-unit profit margins. Production that was sub-economic without the support measure becomes more viable, and production that was already viable generates increased profits. Secondly, when the support measure relates to variable inputs – those whose levels can be adjusted in the short run – recipient firms may re-optimize their input mix to incorporate more of the subsidised input. This can lead to expanded firm production in the short run if spare capacity is available.

211. In the short run, support measures linked to variable inputs result in higher per-unit profits and the utilisation of any spare production capacity. In the long run, higher profits encourage firm entry and new investment in additional production capacity. Support measures related to fixed inputs, capital being the most obvious example, have a similar long run impact. Concessionary investment finance, grants for capital investment, and tax concessions linked to capital spending all incentivise new investment by increasing anticipated project financial returns. Ultimately, support measures affecting variable and fixed inputs both contribute to a new long run equilibrium involving increased production and lower output prices.

6.2.2 *Measures incident on downstream producers: enterprise income*

212. Downstream metal processors in some countries benefit from support measures which increase their enterprise income – the aggregate income earned from business activity. These measures are mostly related to foregone tax revenues; specific examples include differential income tax rates – which can be targeted by sector, geographic area, or firm size – and extended tax loss carry forward provisions. Firms respond in a similar way as for measures affecting input prices; per-unit profits increase and previously marginal production may become economic, potentially leading to increased short run production. The key difference in the short run is that firms have less incentive to alter the mix of inputs used in production.

In the longer run, support measures which affect enterprise income will encourage new investment and firm entry in the same way as for other forms of support.

6.2.3 *Measures incident elsewhere in metals value chains*

213. Downstream metal smelters and refiners also benefit from support which is transmitted from agents operating elsewhere in metal value chains. There are two main mechanisms. First, many government budgetary transfers to the metals industry are received by upstream firms undertaking extraction and upgrading activities. Examples in the primary sector include concessionary mining finance, targeted fuel excise tax exemptions, and concessionary royalty rates. Secondary sector examples include the public provision of separate recycling collection services and public grants or concessionary loans linked to material sorting facilities. Under certain conditions (see below), a proportion of upstream support may be transmitted through the value chain in the form of lower intermediate input prices.

214. Secondly, certain regulatory policies can induce transfers between firms operating in different parts of the metals value chain. Export restrictions on unprocessed raw materials restricts upstream firms' access to international markets; domestic downstream smelting and refining firms potentially benefit from reduced domestic feedstock prices. In the secondary sector, EPR schemes and landfill taxes introduce additional costs for manufacturing and disposal firms, while potentially lowering the cost of intermediate feedstock inputs downstream.

215. Downstream firms respond to indirect support passed through the value chain in a similar way to that described for direct support measures which lower variable input prices. Output and profits are likely to increase in the short run leading to investment in additional production capacity in the long run. Clearly, the size of the downstream firm response depends on both the size of the initial government transfer (or stringency of the policy in the case of regulatory measures), and the degree to which it is transmitted along the value chain. All else equal, higher pass through rates are likely when upstream markets are more competitive, downstream demand is more inelastic, and sectoral value chains are more vertically integrated.

6.2.4 *Empirical evidence*

6.2.4.1 *Firm response in the short run*

216. There is a small body of empirical work assessing how smelters and refineries respond to fluctuating input prices. This literature consistently finds that metal processing firms are unresponsive to factor price variability in the short run, both in terms of input demand and output supply. Based on a panel dataset of European primary aluminium smelters, Blomberg (2007) finds that the own price elasticity of electricity demand is -0.027; a 10% decrease in electricity prices only increases demand by 0.3%. Assessments of secondary aluminium plant supply find that output elasticities are low with respect to scrap feedstock prices (-0.10), electricity prices (-0.25) and scrap stocks (0.07) (Blomberg and Hellmer, 2000; Blomberg and Soderholm, 2009). Similar estimates exist for secondary copper facilities; output elasticity with respect to scrap stocks was estimated to be 0.003 by Gomez et al. (2007).

217. These findings suggest that support measures which affect input costs have a limited immediate impact on firm production decisions, and therefore on primary – secondary market share in the short run. Several explanations are commonly given. First, finished metal production is often considered to be characterised by a 'putty-clay technology' (Blomberg, 2007), where factor proportions are optimised ex-ante, and become fixed following plant design and construction. This 'built in' factor mix serves to limit substitution opportunities as input prices fluctuate. Supply constraints for certain inputs may have a similar effect; lower scrap feedstock prices are of little use when scrap availability is limited by the annual

flow of EOL scrap from in-use metal stocks. Finally, there may be little opportunity to take advantage of lower factor prices in the short run when plants are already operating at, or close to, capacity.

6.2.4.2 *Firm response in the long run*

218. Metal production could be expected to be more responsive to the provision of support in the long run; capacity constraints become less binding because production capacity can adjust to new market conditions. There is little data available for the primary sector. One empirical assessment for the finished copper market finds that primary supply is more sensitive to output prices and input (electricity) prices in the long run (Vial, 2004). Fisher et al. (1972) finds a similar result for copper mine production; the elasticity of output with respect to price is significantly larger in the long run.

219. Although the number of studies is limited, empirical assessments of secondary metal sector often find that finished metal supply with respect to both output and input prices is less elastic in the long run (Fisher et al. 1972; Vial, 2004; Valencia, 2005). Blomberg and Soderholm (2009) state that “even though in the long-run expansion of secondary processing capacity is possible, the long-run supply elasticity of secondary aluminium output may not necessarily be higher than the short-run elasticity”.

220. One probable explanation relates to constrained availability of secondary scrap metal feedstock. Scrap flows originate from both the in-use stock of capital goods and the use and subsequent disposal of short lived consumer goods. The size of the former flow is determined by the amount of historic capital investment and the lifetime of these capital goods. The size of the latter is largely a function of aggregate current period consumption. These factors are unrelated to market forces in secondary scrap markets; increased feedstock demand will put upward pressure on material recovery rates, but cannot fundamentally increase the flow of scrap. This becomes especially important where material recovery rates are already high; modelling by UNEP suggests that end of life recovery rates for titanium, chromium, and iron (ie., steel) are around 80%.

6.3 Impact of support on aggregate primary and secondary market share

221. The above discussion outlined how metal re-melting, smelting, and refining firms respond to support. It applied equally to primary and secondary firms, although the potential constraints affecting secondary scrap supply may mean that secondary firms are less sensitive to the provision of support. Similarly, market power in the primary sector may limit the extent to which upstream support is passed through to processing firms. The remainder of this chapter assesses how support might translate into distorted primary and secondary market share at both the domestic and global level, and how this can lead to certain environmental consequences. Figure 20 summarises these relationships.

Figure 20. The economic and environmental impacts of support

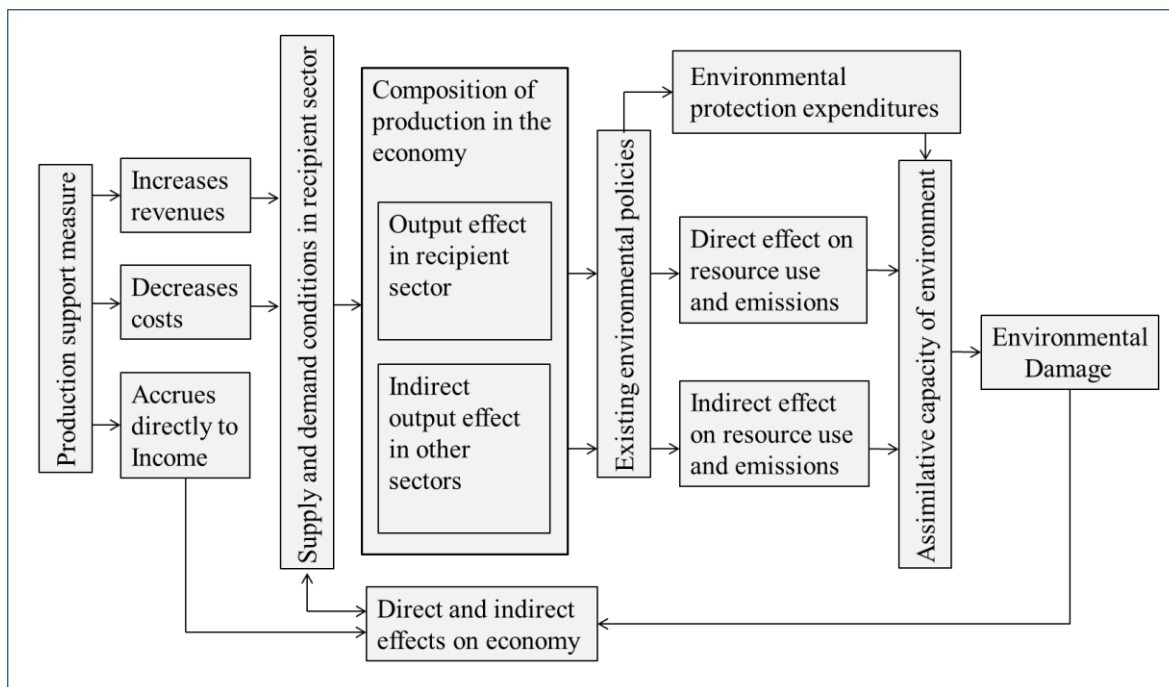

Source: Adapted from IEA et al. (2010)

6.3.1 Competition in metals markets

222. Competition between firms in the primary and secondary metals sector takes place mostly at the smelting or refining stage in the metals value chain (see Figure 1). Process plants using feedstock derived from virgin natural resources produce finished products with qualities which are very similar or identical to those produced by plants using scrap feedstock. In general, there is little competition between primary and secondary metal products higher in the value chain. Smelters and refineries are typically optimised to process either primary or secondary feedstock; they have limited capacity to alternate between the two in the short run. There are certain exceptions. Significant quantities of steel scrap are utilised in the primary Blast Oxygen Furnace (BOF) steel production process. Scrap base metal alloys may occasionally be used in integrated processing facilities. In general however, cost efficient finished metal production is facilitated by the use of single feedstock with consistent properties

223. Primary and secondary metal processing facilities produce finished metal products that are perfect, or near perfect substitutes for each other. The Aluminium Association, an industry group in the United States, states that there is “no material difference” between aluminium produced from primary and secondary feedstock; it has the “same physical properties” (Aluminium Association, 2011). For copper, a report from the Centre of European Policy Studies (CEPS) states that “the production of copper from scrap does not affect its properties ... secondary copper typically can’t be distinguished from primary” copper (CEPS, 2013). In certain specific situations however, there may be an element of differentiation in finished primary and secondary metal products. Secondary metal is most likely to have inferior properties relative to the primary equivalent when scrap feedstock containing impurities is processed in a re-melting facility. Impurities tend to be incorporated into the finished metal where they result in lower performance characteristics and product differentiation. This is particularly important in high performance applications such as those in the aerospace industry; even small impurities can result in much diminished performance.

224. Finished metal products are bought by a range of agents, including foundries, mills, fabricators, and component manufacturers. Metals markets have become increasingly globally interconnected with the liberalisation of trade in recent decades. A report by the Centre for European Policy Studies suggests that aluminium and copper markets are developed enough to be considered global (Berg et al. 2013). International prices exist for a number of finished metal products; prices on the London Metals Exchange are an important benchmark and often serve as reference prices for transactions not made through the exchange (Figuerola-Ferretti and Gilbert, 2005; CEPS, 2013). More recently, monthly metal trade volumes on the Shanghai Futures Exchange (SHFE) have increased substantially (Ferretti et al. 2014); these are frequently used as a reference for Asia based transactions (Sanderson, 2015).

225. Market power held by metal smelting and refining firms is limited for most metals by the increasing interconnectedness of global markets. For aluminium and nickel, Figuerola-Ferretti (2005) states that, the ‘prerequisites for oligopolistic co-ordination were gradually removed’ following the entry of new fringe producers during the 1980’s. Despite this, the largest producers of most finished metals continue to represent a significant share of world production. For steel, aluminium, and finished copper, the largest four producer firms in 2014/2015 represented ~14%, ~25%, and ~27% of world production respectively (see Chapter 1). The largest producer firm for each of these commodities – Arcelor Mittal, UC Rusal, and Codelco – represented ~6%, ~7%, and ~9% of total production.

226. As highlighted in Chapter 1, the share of downstream production held by plants using primary feedstock is in the order of 80% for steel, aluminium, and copper. Although primary – secondary production data disaggregated by firm is unavailable, it is unlikely that significant market power exists within the secondary sector due to its smaller size. Downstream secondary producers are mostly price takers in world markets.

227. In sum, the above set-up is largely consistent with recent theoretical analyses which represent the metals sector in terms of a dominant oligopolistic (primary) sector competing with a smaller secondary sector composed of dominantly price taking firms (Di Vita, 2007; Blomberg and Soderholm, 2009; Boyce, 2012; Zinc et al. 2015).

6.3.2 *How support distorts competition between the primary and secondary metal sectors*

228. The aggregate impact of government support follows largely from individual firm responses. Short run supply responses may be relatively muted for several reasons, but increased profits or lower investment costs will tend to encourage firm entry, new investment, and increased production in the longer run. Ultimately, expanded aggregate supply will lead to a new long run equilibrium characterised by increased finished metal production and lower market prices. High cost production (both primary and secondary facilities) located domestically and in third party countries will become increasingly uncompetitive as metal prices fall, leading to firm exit or the creation of retaliatory support measures.

229. The extent to which domestic primary – secondary market share is distorted by government support depends on a range of factors. Clearly, the specificity of support is important; measures which accrue exclusively to one sector will serve to increase that sector’s production share. The magnitude of support is also critical; firm production decisions will be increasingly distorted as support measures become more generous. In countries where metal is produced exclusively by either the primary or secondary sector, targeted support simply serves to reinforce that sectors dominance. In countries with well-developed primary and secondary metals sectors, differential levels of support will result in modified domestic primary – secondary production share. Two assessments of differential support are known for Canada (Scharf, 1999) and Sweden (Johansson et al. 2014); both conclude that primary support is relatively larger in per-unit terms, but neither study attempts to translate that into market share.

230. One dollar of per-unit support received by the primary and secondary metal sector may not translate into domestic downstream production share in the same way (Zink et al. 2015). As highlighted previously, support received by downstream secondary metal re-melters will have a limited impact on aggregate secondary production if scrap supply is limited. The volatility of scrap metal prices may also dampen the long run impact of secondary support if incentives to invest in new secondary processing capacity are reduced. In a similar way, different patterns of industrial organisation in primary and secondary metal value chains influence whether support is passed through. The upstream portion of the primary metal value chain is characterised by higher levels of market power than the secondary equivalent. Support received by large mining firms will not necessarily be conveyed further downstream in the form of lower intermediate metal prices.

231. Global primary – secondary market share is important because some externalities associated with metal production have global impacts (e.g., greenhouse gas emissions). Support provided in producer countries can influence primary – secondary market share elsewhere if firms representing a sufficiently large share of world production are recipients (Box 2). Sector specific upstream support available in one large producer country may place enough downward pressure on world feedstock prices to distort downstream primary – secondary competition elsewhere. Alternatively, support received by domestic downstream metal producers in one jurisdiction could depress world finished metal prices enough to render high-cost production located elsewhere sub-economic.

Box 2. International impacts of domestic support

The geographic concentration of upstream mineral ore and scrap production in a small number of countries means that the metals industry is characterised by large trade flows. Metal value chains often span national borders; final metal production in one country may utilise intermediate feedstock that was originally extracted or recovered elsewhere. In 2014, China accounted for almost half of all primary finished aluminium production despite only having 16% of global bauxite mine production (USGS, 2016). Similarly, in the same year, India accounted for 13% of all secondary steel production, despite having limited domestic sources of steel scrap.

The interconnected character of global metal value chains means that support conferred to firms in the metal sector in one jurisdiction may be conveyed globally through trade. The basic transmission mechanism is as follows. Support measures documented in Chapter 3 and Chapter 4 lead to additional domestic metal production, either in the short run as marginal units become economically viable, or in the long run as domestic investment decisions are affected. Assuming a constant export share, higher levels of production translate into increased global supply, which places downward pressure on international commodity prices. This can confer support for downstream metal processors in third party countries which benefit from reduced input costs. The transmission of domestic support may also bias investment decisions made elsewhere; construction of primary smelters or refineries would be favoured if international feedstock prices were lower than they would be otherwise.

The degree to which the transmission of domestic support influences international primary – secondary metal market share is shaped by several factors. Firstly, the magnitude of domestic support is important; all else equal, higher levels of per-unit support will translate into more additional domestic production. Secondly, support conferred in 'large' exporter countries is more likely to be transmitted elsewhere because a greater proportion of global supply is affected. Finally, whether existing domestic production is economically marginal is important; the creation or removal of support measures is less likely to affect the quantity of low cost production than high cost production.

6.4 From market share to life-cycle environmental impacts

232. Support conferred to metals firms can distort the share of primary and secondary production in finished metal markets. This has important environmental consequences because the production of metal from virgin mineral ores generates a broader range of polluting by-products than production from scrap.

Support measures that serve to boost the share of primary output in total metal production are therefore likely to have negative consequences for overall environmental quality.

233. The environmental impacts of metal production have been extensively discussed in a number of cradle to grave life cycle assessments (Mudd, 2009; UNEP, 2013; Nuss and Eckelman, 2014), and are presented in Figure 21. The following discussion briefly summarises these impacts across three key parts of the metal lifecycle: extraction, upgrading and processing, and disposal¹⁰.

Figure 21. Life-cycle externalities associated with metal production

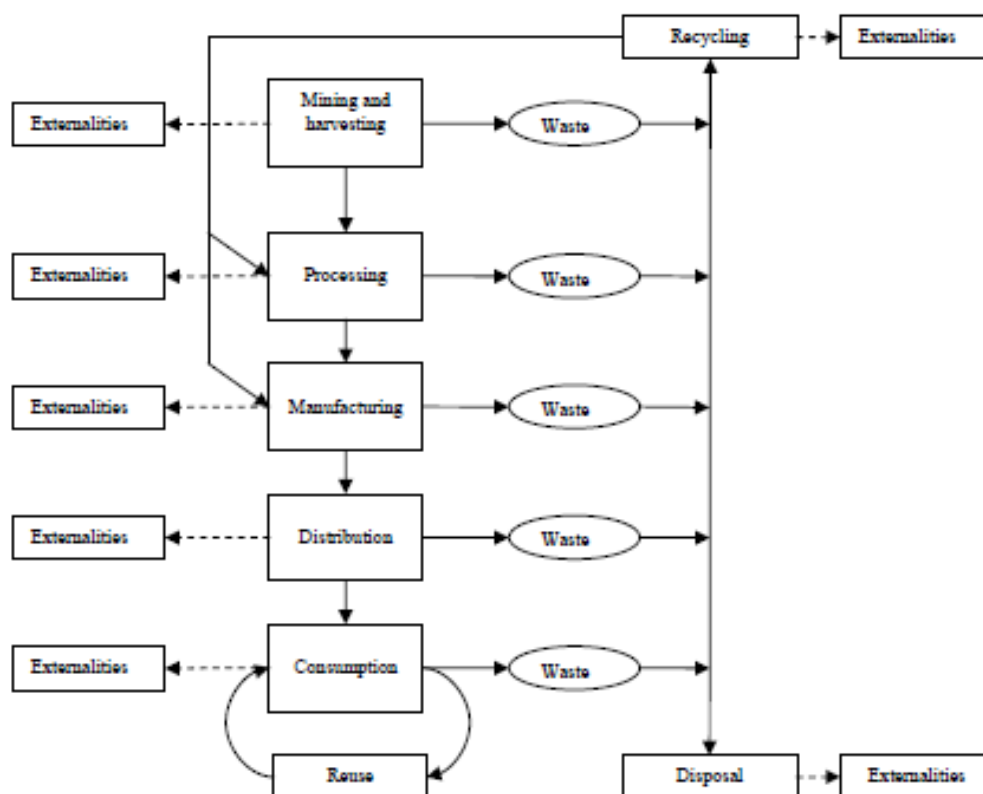

Source: Australia Productivity Commission (2006), Waste Management, Productivity Commission Inquiry Report

234. Metal production involves an initial upstream phase that is characterised by the extraction of virgin mineral ores in the primary sector and the collection of metallic scrap from various waste streams in the secondary sector. These activities have two main environmental impacts. First, the heavy vehicles and other machinery required for the extraction and transport of raw materials typically run on liquid fossil fuels¹¹, generating greenhouse gas and local particulate emissions as a result. There is little data available on the relative energy and carbon intensities of mining and waste collection. For aluminium, a comparison of studies assessing liquid fuel inputs in bauxite mining (OECD, 2006) and aluminium scrap collection (Quinkertz et al. 2001) suggests that both activities have similar energy requirements per tonne of contained aluminium (around 240 MJ/kg Al). Second, the extraction of mineral ores can generate a range

¹⁰ Interested readers are referred to the references provided for additional information.

¹¹ Energy consumption in mining is small, both relative to the energy required in mineral ore processing (Norgate and Jahanshahi, 2011), and relative to total global energy consumption. On the latter, the IEA indicate that mining accounts for less than 1% of global consumption (IEA, 2016)

of local environmental damages that are not encountered in secondary metal production. Surface disturbances associated with mine development, infrastructure construction, and waste dumps can affect large areas, particularly in the case of open pit mining. Further, the exposure of sulphide minerals in mine walls and waste rock dumps can lead to acid mine drainage and increased heavy metal concentrations, with associated consequences for aquatic ecosystems and water supply. Acid mine drainage is often a long term legacy in mining districts; little can be done to remedy the problem once mineralised materials have been exposed to water and oxygen.

235. Transforming virgin mineral ores and metal scrap into finished metals also generates a range of environmental impacts. Again, the greenhouse gas emissions resulting from energy use are significant. The metals industry is estimated to account for 7.5% of global energy consumption (IEA, 2016), with the vast majority of this originating in upgrading and processing activities (Norgate and Jahanashahi, 2011). As highlighted in Chapter 3, the primary metal production process is highly energy intensive - producing finished metals from mineral ore can require as much as two orders of magnitude more energy than doing so from metal scrap¹². This has clear implications for carbon intensity of primary metal production. In addition to the energy requirement, the beneficiation and concentration of virgin mineral ores also requires large volumes of water. This has two main environmental impacts. First, the drawdown or diversion of surface water can lead to water shortages or ecosystem losses, particularly in arid regions. Second, the tailings generated as a by-product often contain high heavy metal concentrations, and can contaminate local groundwater if not properly stored. Environmental damage resulting from tailings spills and smelter or refinery residues are well documented in the mining industry.

236. Finally, the disposal of metals contained in end of life consumer goods or industrial scrap may generate a range of local environmental impacts. Under certain conditions, landfilling of metallic waste may lead to metal leaching and the contamination of local soil and groundwater. This is most likely where landfilled materials contain significant concentrations of arsenic, cadmium, lead, mercury, or other toxic elements; e-waste, pigments, and batteries are potentially important products in this regard (Kiddee et al. 2013). Even metals that are biologically essential may become toxic to certain organisms at high concentrations. Environmental damages associated with waste incineration and landfilling do not directly result from primary or secondary metal production, but are partly a function of primary – secondary sector market share. Any measure that increases the proportion of finished metal produced from scrap will tend to have favourable environmental consequences. Scrap recovery and recycling rates will increase, which simultaneously serves to reduce the extraction of virgin mineral ores and the disposal of potentially toxic metal scrap

¹² This is largely a consequence of the beneficiation and metallurgical processes that are required to separate metal from the other constituent materials of mineral ore. These activities are highly energy intensive and are largely absent from the secondary production process.

7. SUPPORT FOR METALS PRODUCTION: TAKING STOCK AND LOOKING FORWARD

7.1 The contribution of this report

237. This report has documented the measures that are commonly used to confer support to the metals industry. Support is provided by different levels of government; that for the primary sector usually originates at the national level, while that for the secondary sector is more often from state or provincial governments. Support is mostly received directly by producers; the consumption subsidies that have been documented in other sectors (e.g. fossil fuels) are largely unknown. In many cases, support is non-targeted; it is theoretically available for both primary and secondary metal producers. That said, measures that serve to reduce the cost of energy and capital may disproportionately accrue to primary metal producers due to their relatively intensive use of these inputs. Finally, support for the secondary sector appears to address market failures to a greater extent than those in the primary sector, and are therefore more likely to be welfare enhancing.

238. The incidence of support, and the mechanisms through which it is provided, varies according to a country's development status and mineral endowment (Table 10). Support for primary metal production appears to be most widespread in emerging economies endowed with domestic mineral resources. Mining and mineral processing operations in these jurisdictions are often, at least partially, state-owned, and may not be subject to the same commercial realities as privately owned competitors. Export restrictions on unprocessed mineral ores and tax holidays designed to stimulate investment in downstream processing capacity are also well documented. That said, support for primary metal production is also available in more advanced economies. For example, in developed countries with domestic mineral resources, support is often provided via the tax system, but also through the public provision of services (e.g. geoscientific information) at below cost recovery. Even in developed economies lacking domestic resources, support has been documented. One example relates to the energy tax exemptions that are available for metal smelters that operate using imported primary ores or concentrates.

239. Support for secondary metal production is most widespread in advanced economies (Box 2). Developed countries, including those with and without domestic mineral resources, often provide support for domestic recyclers and re-processors through targeted investment schemes – non-repayable grants, concessionary debt financing, and loan guarantees have all been documented. Similarly, waste management policies – landfill taxes, EPR schemes, and the public provision of separated recycling collection – can induce transfers to the secondary sector, albeit without any direct financial outlay for governments. Export restrictions on metal scrap and end of life goods containing metals also induce transfers to the secondary sector, and seem to be more prevalent in developed countries lacking domestic resources.

240. Support typically serves to reduce costs for recipient firms in the metals industry. In the short run, this stimulates additional production as previously sub-economic output becomes viable and firms utilise spare production capacity. In the longer run, the higher profits resulting from support can encourage firm entry and investment in additional production capacity. To the extent that support increases the share of primary output in total metal production, it will also have negative consequences for overall environmental quality; primary metal production generates a broader range of polluting by-products than its secondary equivalent. One key determinant in this is the relative magnitude, and distribution, of support for the primary and secondary sectors. Further work is required to better establish this.

Table 10. Common modes of support according to, (i) resource endowment, and (ii) development status

		DOMESTIC MINERAL RESOURCES	LIMITED MINERAL RESOURCES
MORE INDUSTRIALISED	EXAMPLE COUNTRIES	Australia, Canada, Sweden, United States	European Union, Japan, South Korea
	CHARACTERISTICS	Full primary metal supply chain: Mine to final metal production. Well developed secondary sector	Downstream primary sector utilises imported intermed feedstock. Well developed secondary sector
	PRIMARY SUPPORT	Provision of services: advanced geoscientific data Tax system: measures relating to capital and energy	Tax system: measures relating to capital and energy
	SECONDARY SUPPORT	Grants or finance linked to capital investment Environmental regulation: EPR and separated collection	Grants or finance linked to capital investment Environmental regulation: EPR and landfill taxation Export restrictions on scrap products
LESS INDUSTRIALISED	EXAMPLE COUNTRIES	LATIN AMERICA: Argentina, Brazil, Chile, Peru ASIA: China, Indonesia, Phillipines, Mongolia AFRICA: DRC, Zambia	NORTH AFRICA: Algeria, Tunisia SOUTH ASIA: Bangladesh, India
	CHARACTERISTICS	Upstream primary sector with limited downstream processing. Informal or little developed secondary sector	Poorly developed primary sector: finished metals imported. Informal or poorly developed secondary sector
	PRIMARY SUPPORT	Provision of public investment finance Tax system: measures to downstream investment Below cost provision of intermediate inputs by SOE's Export restrictions	Limited
	SECONDARY SUPPORT	Limited	Limited

Source: Own compilation

7.2 The way forward: quantifying the value of support for the metals sector

241. There is a clear knowledge gap concerning the types and value of support available for metal production and consumption. Although there are some instructive publications on the subject (see Sections 3.2 and 4.2), the scope of these is generally restricted to a particular country, sector, or type of support measure. In contrast to several other potentially environmentally harmful sectors (e.g., agriculture, fossil fuels, fisheries), there is no comprehensive cross-country database of government support that covers a broad set of measures and commodities. This is perhaps surprising given preliminary indications of the magnitude of support for primary metal production¹³, and the relevance of minerals and metals to a circular economy transition.

242. There are two main reasons why developing a cross-country assessment of support to the metals sector would be worthwhile. First, it would increase transparency on the various mechanisms that governments use to provide support to metals firms. Questions such as, what is the relative magnitude of support provided across countries, which support measures are most important, and to what extent does the secondary sector also benefit, could be better addressed. Second, the data created during such an assessment would facilitate analyses of the economic impacts of support. Questions such as, how responsive is metal output to the provision of support, could potentially be addressed.

243. There are three possible options for advancing the current stock of knowledge on support for the metals sector (see Annex 3 for a full discussion). From lesser to greater levels of ambition, these are, (i)

¹³ The value of this support has been found to extend into the billions of dollars in several countries. See Annex 2 for additional information.

individual country case studies, (ii) a qualitative cross-country inventory, and (iii) a quantitative cross-country inventory. The most appropriate course of action will depend on both the resources that can be mobilised for the work, and the applications that the data is expected to be used for. If the main intention is to raise awareness around the magnitude of support for primary metal production, then a series of case studies in important metal producing countries may suffice. Introducing support for secondary production to the analysis would be required if the goal is to establish the relative magnitude of support for the primary and secondary sectors. Finally, more detailed data collection would be worthwhile if the database was expected to become the basis for an empirical analysis on the effects of support. In that case, additional temporal coverage and disaggregation of the value of support measures by recipient metal would be recommended.

REFERENCES

- ABREE, (2016). Resources and Energy Statistics. [online] Available at:
<http://www.industry.gov.au/Office-of-the-Chief-Economist/Publications/Pages/Resources-and-energy-statistics.aspx>
- Aluminium Association, (2011). Aluminum: The Element of Sustainability. [online] Available at:
http://www.aluminum.org/sites/default/files/Aluminum_The_Element_of_Sustainability.pdf
- Aluminium Leader, (2016). World Aluminium Market. [online] Available at:
http://www.aluminiumleader.com/economics/how_aluminium_market_works/
- Ayres, R. (1997). Metals recycling: economic and environmental implications. *Resources, Conservation and Recycling*, 21(3), pp.145-173.
- BIR, (2008). Report on the Environmental Benefits of Recycling. [online] Available at: https://carri-acir.org/wp-content/uploads/2014/08/BIR_CO2_report.pdf
- Blomberg, (2007). Essays on the Economics of the Aluminium Industry. [online] Available at:
<https://pure.ltu.se/portal/files/415857/LTU-DT-0706-SE.pdf>
- Blomberg, J. and Hellmer, S. (2000). Short-run demand and supply elasticities in the West European market for secondary aluminium. *Resources Policy*, 26(1), pp.39-50.
- Blomberg, J. and Söderholm, P. (2009). The economics of secondary aluminium supply: An econometric analysis based on European data. *Resources, Conservation and Recycling*, 53(8), pp.455-463.
- Boyce, J. (2012). Recycling of Non-Renewable Resources and the Least-Cost-First Principle. [online] Available at: <http://economics.ca/cree2012/paper/067.pdf> [Accessed 24 Sep. 2016].
- Bruce, N. (1990). Measuring Industrial Subsidies. OECD Economics Department Working Papers.
- CEPS, (2013). Price Formation In Commodities Markets: Financialisation And Beyond. [online] Available at: <https://www.ceps.eu/system/files/commodtfr.pdf>
- CEWEP, (2015). Landfill Taxes and Bans. [online] Available at:
http://www.cewep.eu/media/www.cewep.eu/org/med_557/1406_2015-02-03_ceilp_-_landfill_inctaxesbans.pdf
- Chalmin, P., Gaillochet, C. and Hayes, S. (2009). From waste to resource. Paris: Économica.
- Clayton, T. (2016). The Iron and Steel Industry in China. [online] Available at:
<https://sites.utexas.edu/mecc/2014/05/01/the-iron-and-steel-industry-in-china-part-i/>

- Climate Bonds Initiative, (2015). 1st recycling #GreenBond from France's Paprec. [online] Available at: <https://www.climatebonds.net/2015/03/wkly-blog-1st-recycling-greenbond-france%E2%80%99s-paprec-another-1st-greenbond-swedish-wallenstam>
- Climate Bonds Initiative, (2016). Labelled green bonds data. [online] Available at: <https://www.climatebonds.net/cbi/pub/data/bonds>
- Coulomb, R., Dietz, S., Godunova, M. and Nielson, T. (2016). Critical Minerals Today and in 2030. [online] Available at: http://www.oecd-ilibrary.org/environment/critical-minerals-today-and-in-2030_5jrknwm5hr5-en?crawler
- Di Vita, G. (2007). Exhaustible resources and secondary materials: A macroeconomic analysis. *Ecological Economics*, 63(1), pp.138-148.
- DoITPoMS, (2016). TLP Library Recycling of Metals - • Eddy current separation. [online] Available at: http://www.doitpoms.ac.uk/tlplib/recycling-metals/eddy_current.php
- EC, (2015). Assessment of separate collection schemes in the 28 capitals of the EU. [online] Available at: http://ec.europa.eu/environment/waste/studies/pdf/Separate%20collection_Final%20Report.pdf
- EC, (2016). The Investment Plan for Europe: A State of Play. [online] Available at: https://ec.europa.eu/priorities/sites/beta-political/files/sector_environment_june.pdf
- ECI, (2016). The Essential Chemical Industry. [online] Available at: <http://www.essentialchemicalindustry.org/metals/copper.html>
- EIB, (2015). European Fund for Strategic Investments – Questions and Answers. [online] Available at: http://www.eib.org/attachments/press/investment_plan_for_europe_qa_en.pdf
- EIB, (2016). InnovFin: EU Finance for Innovators. [online] Available at: http://www.eib.org/attachments/innovfin_faq_en.pdf
- Electronic Recyclers International, (2016). U.S. Landfill Ban. [online] Available at: <http://electronicrecyclers.com/sustainability/us-landfill-ban>
- Energy Post, (2016). China's rapidly changing power mix: did CO2 emissions peak?. [online] Available at: <http://www.energypost.eu/chinas-electricity-mix-changing-fast-co2-emissions-may-peaked/>
- ETP/SCP, (2012). Overview of the use of landfill taxes in Europe. [online] Available at: http://scp.eionet.europa.eu/publications/WP2012_1/wp/WP2012_1
- Eurostat, (2011). Environmental Taxes: A Statistical Guide. [online] Available at: <http://ec.europa.eu/eurostat/documents/3859598/5936129/KS-GQ-13-005-EN.PDF>
- Eurostat, (2016). Waste statistics. [online] Available at: http://ec.europa.eu/eurostat/statistics-explained/index.php/Waste_statistics
- Federal Government, (2016). National waste stream profiles. [online] Available at: <https://www.environment.gov.au/topics/environment-protection/nwp/reporting/national-waste-stream>

Figuerola-Ferretti, I. and Gilbert, (2005). Price Formation in the Aluminium Market. [online] Available at: http://web.unitn.it/files/6_05_gilbert.pdf

Figuerola-Ferretti, I., Gilbert, C. and Yan, J. (2014). Copper Price Discovery on Comex, the LME and the SHFE, 2001-2013. [online] Available at: <https://ideas.repec.org/p/cte/wbrepe/wb140402.html>

Fisher, F., Cootner, P. and Baily, M. (1972). An Econometric Model of the World Copper Industry. *The Bell Journal of Economics and Management Science*, 3(2), p.568.

Fogarty, J. and Sagerer, S. (2016). Exploration externalities and government subsidies: The return to government. *Resources Policy*, 47, pp.78-86.

Fothergill, J. (2004). Scrap Mining: An Overview of Metal Recycling in Canada. [online] Available at: http://www.canaryinstitute.ca/publications/Scrap_Mining.pdf

Fullerton, D. and Kinnaman, T. (1995). Garbage, Recycling, and Illicit Burning or Dumping. *Journal of Environmental Economics and Management*, 29(1), pp.78-91.

GIB, (2016). Green Investment Bank - Our investments. [online] Available at: <http://www.greeninvestmentbank.com/our-investments/?sector=waste-and-bioenergy#main>

Goldman Sachs, (2013). Resource Nationalism Poses Big Threat to Miners. [online] Available at: http://www.minerals.org.au/policy_focus/taxation/

Goley, A. and Corder, G. (2016). Modelling metal flows in the Australian economy. *Journal of Cleaner Production*, 112, pp.4296-4303.

Gómez, F., Guzmán, J. and Tilton, J. (2007). Copper recycling and scrap availability. *Resources Policy*, 32(4), pp.183-190.

Griffith, M. (2016). Measures Supporting Minerals And Primary Metals Extraction And Processing - Case Study: Australia. [online] *Oecd.org*. Available at: [http://www.oecd.org/officialdocuments/publicdisplaydocumentpdf/?cote=COM/TAD/ENV/JWPTE\(2012\)28/FINAL&docLanguage=En](http://www.oecd.org/officialdocuments/publicdisplaydocumentpdf/?cote=COM/TAD/ENV/JWPTE(2012)28/FINAL&docLanguage=En)

GSI, (2010). Subsidy Estimation: A survey of current practice. [online] Available at: https://www.iisd.org/gsi/sites/default/files/sub_manual.pdf

Haley, U. and Haley, G. (2013). The Hidden Advantage of Chinese Subsidies. *State Capitalism, Business Strategy, and Trade Policy*, pp.1-28.

IEA et al. (2010). Analysis Of The Scope Of Energy Subsidies And Suggestions For The G-20 Initiative. [online] Available at: <https://www.oecd.org/env/45575666.pdf>

IEA, (2016). Sankey Diagram: World Final Energy Consumption. [online] Available at: [http://www.iea.org/Sankey/#?c=World&s=Final consumption](http://www.iea.org/Sankey/#?c=World&s=Final%20consumption)

IFC, (2015). IFC and MIGA to Provide More Than \$2 Billion for Oyu Tolgoi, Engine of Mongolian Jobs and Growth. Available at: <http://ifcextapps.ifc.org/ifcext%5CPressroom%5CIFCPressRoom.nsf%5C0%5CC64D74678BB89E2985257F1C0050C813>

- IMF, (2015). IMF Working Paper: How Large Are Global Energy Subsidies?. [online] Available at: <https://www.imf.org/external/pubs/ft/wp/2015/wp15105.pdf>
- Intelligence Mine, (2016). IntelligenceMine Database. [online] Available at: <http://www.mining.com/author/intelligencemine/>
- IWSA, (2015). Circular Economy: Trends and Emerging Ideas. [online] Available at: https://www.iswa.org/fileadmin/galleries/Task_Forces/Task_Force_Report_1_02.pdf
- Johansson, N., Krook, J. and Eklund, M. (2014). Institutional conditions for Swedish metal production: A comparison of subsidies to metal mining and metal recycling. *Resources Policy*, 41, pp.72-82.
- Kiddee, P., Naidu, R. and Wong, M. (2013). Electronic waste management approaches: An overview. *Waste Management*, 33(5), pp.1237-1250.
- Kluender, E. (2013). Quantification of Water Footprint: Calculating the Amount of Water Needed To Produce Steel. [online] Available at: <http://docs.lib.purdue.edu/jpur/vol3/iss1/9/>
- Koplow, D. (1994). Federal Energy Subsidies and Recycling. [online] Available at: <https://earthtrack.net/sites/default/files/Alum%20Subs%2C%20Res%20Recyc%20Article.pdf>
- KPMG, (2013). The KPMG Green Tax Index. [online] Available at: <https://assets.kpmg.com/content/dam/kpmg/pdf/2013/08/kpmg-green-tax-index-2013.pdf>
- Lambrechts, K., Darimani, A., Kabemba, C. and Olaleye, W. (2009). Breaking the Curse, how Transparent Taxation and Fair Taxes can turn Africa's Mineral Wealth into Development. [online] Available at: <http://www.christianaid.org.uk/Images/breaking-the-curse.pdf>
- Larson, v. (2014). E&MJ's Annual Survey of Global Metal-mining Investment. [online] Available at: <http://www.e-mj.com/features/3674-e-mj-s-annual-survey-of-global-metal-mining-investment.html#.V-aU1k1PrIV>
- MacLean, H. L., Duchin, F., Hagelüken, C., Halada, K., Kesler, S. E., Moriguchi, Y. (2010). Stock, flows and prospects of mineral resources. In T. E. Graedel, & E. van der Voet, (eds.) *Linkages of sustainability*. Cambridge: MIT Press.
- Mayer Brown, (2015). African Mining Law Updates. [online] Available at: https://www.mayerbrown.com/files/uploads/Documents/PDFs/2016/January/RSpeight_African_Mining_Law_Updates_Article.pdf
- McPherson, C. (2008). State Participation In The Natural Resource Sectors: Evolution, Issues And Outlook. [online] Available at: <http://www.imf.org/external/np/seminars/eng/2008/taxnatural/pdf/mcpherson.pdf>
- MineWeb, (2016). Copper's top 10 – Countries and Companies. [online] Available at: <http://www.mineweb.com/news/base-metals-and-minerals/coppers-top-10-countries-and-companies/>
- Mudd, G. (2009). Prediction of Greenhouse Gas Emissions for the Olympic Dam Mega-Expansion. [online] Available at: <http://users.monash.edu.au/~gmudd/files/2009-04-CO2-Pred-v-ODam.pdf>
- NRCAN, (2017a). Canadian Exploration Expense Claims. [online] Available at: <http://www.nrcan.gc.ca/mining-materials/taxation/mining-specific-tax-provisions/8892#lnk8>

- NERC, (2011). Disposal Bans & Mandatory Recycling in the United States. [online] Available at: https://nerc.org/documents/disposal_bans_mandatory_recycling_united_states.pdf
- Norgate, T. and Jahanshahi, S. (2011). Reducing the greenhouse gas footprint of primary metal production: Where should the focus be?. *Minerals Engineering*, 24(14), pp.1563-1570.
- Norgate, T., Jahanshahi, S. and Rankin, W. (2007). Assessing the environmental impact of metal production processes. *Journal of Cleaner Production*, 15(8-9), pp.838-848.
- Nuss, P. and Eckelman, M. (2014). Life Cycle Assessment of Metals: A Scientific Synthesis. *PLoS ONE*, 9(7), p.e101298.
- OECD, (2005). Environmentally Harmful Subsidies: Challenges for Reform. [online] Available at: http://www.oecd.org/tad/fisheries/environmentallyharmfulsubsidieschallengesforreform.htm?_sm_a_u_=iqVF4vT022Z302T6
- OECD, (2006). Materials Case Study 2: Aluminium. [online] Available at: <https://www.oecd.org/env/waste/46194971.pdf>
- OECD, (2007). Subsidy reform and sustainable development. Paris, France: OECD.
- OECD, (2011a). Environmental Taxation: A Guide for Policy Makers. [online] Available at: <https://www.oecd.org/env/tools-evaluation/48164926.pdf>
- OECD, (2011b). Making steel more green: challenges and opportunities. [online] Available at: <https://www.oecd.org/sti/ind/48328101.pdf>
- OECD, (2012). Overview Of Key Methods Used To Identify And Quantify Environmentally Harmful Subsidies With A Focus On The Energy Sector. [online] Available at: [https://www.oecd.org/env/outreach/EAP\(2012\)2_NP_Subsidies%20report_ENG.pdf](https://www.oecd.org/env/outreach/EAP(2012)2_NP_Subsidies%20report_ENG.pdf)
- OECD, (2014). Export Restrictions in Raw Materials Trade: Facts, Fallacies and Better Practices. [online] Available at: <http://www.oecd.org/tad/benefitlib/export-restrictions-raw-materials.htm>
- OECD, (2015a). Material Resources, Productivity and the Environment. OECD Green Growth Studies.
- OECD, (2015b). OECD Companion to the Inventory of Support Measures for Fossil Fuels 2015. Paris: OECD Publishing.
- OECD, (2015c). Green bonds Mobilising the debt capital markets for a low-carbon transition. [online] Available at: <https://www.oecd.org/environment/cc/Green%20bonds%20PP%20%5bf3%5d%20%5blr%5d.pdf>
- OECD, (2016a). OECD's Producer Support Estimate And Related Indicators Of Agricultural Support. [online] Available at: <http://www.oecd.org/tad/agricultural-policies/full%20text.pdf>
- OECD, (2016b). Database on instruments used for environmental policy. [online] Available at: <http://www2.oecd.org/ecoinst/queries/#>
- OECD, (2016c). OECD Tax Database [online] Available at: <http://www.oecd.org/tax/tax-policy/tax-database.htm>

- OECD, (2016d). Green Investment Banks. [online] Available at:
<https://www.oecd.org/environment/cc/Green-Investment-Banks-POLICY-PERSPECTIVES-web.pdf>
- OECD, (2016e). Extended Producer Responsibility: Guidance for Efficient Waste Management. [online]
 Available at: <http://www.oecd.org/environment/waste/Extended-producer-responsibility-Policy-Highlights-2016-web.pdf>
- OECD, (2016f). Export restrictions on Industrial Raw Materials. [online] Available at:
http://qdd.oecd.org/subject.aspx?Subject=ExportRestrictions_IndustrialRawMaterials
- Otto, J., Batarseh, M. and Cordes, J. (2000). Global mining taxation comparative study. Golden, Colo.:
 Institute for Global Resources Policy and Management, Colorado School of Mines.
- Peel, M., Campbell, R. and Denniss, R. (2016). Mining the Age of Entitlement. [online] Available at:
<http://www.tai.org.au/sites/default/files/Mining%20the%20age%20of%20entitlement.pdf>
- Pembina Institute, (2002). Looking Beneath the Surface: An Assessment of the Value of Public Support for
 the Metal Mining Industry in Canada. [online] Available at: <https://www.pembina.org/pub/145>
- PNG Department of Minerals, (2013). SPC-EU EDF10 DEEP SEA MINERALS (DSM) PROJECT.
 [online] Available at:
http://dsm.gsd.spc.int/public/files/meetings/STATE_S_EQUITY_PARTICIPATION.pdf
- Productivity Commission, (2006). Waste Management, Productivity Commission Inquiry Report [online]
 Available at: http://www.pc.gov.au/__data/assets/pdf_file/0014/21614/waste.pdf
- PWC, (2012). Corporate income taxes, mining royalties and other mining taxes: A summary of rates and
 rules in selected countries. [online] Available at: http://www.pwc.com/gx/en/industries/energy-utilities-mining/publications/corporate-income-taxes-mining-royalties-and-other-mining_taxes.html
- PWC, (2015). Energy, Utilities, and Mining Newsflash. [online] Available at:
<https://www.pwc.com/id/en/home/assets/PwC%20Indonesia%20-%20EU&M%20NewFlash%20No.%2057-2015.pdf>
- Quinkertz, R., Rombach, G. and Liebig, D. (2001). A scenario to optimise the energy demand of
 aluminium production depending on the recycling quota. Resources, Conservation and Recycling,
 33(3), pp.217-234.
- Roy Hill, (2014). Roy Hill Secures Debt Finance. [online] Available at: <https://www.royhill.com.au/wp-content/uploads/2014/03/Roy-Hill-Secures-Debt-Finance-Agreement1.pdf>
- SAICA, (2004). Value Added Tax: Second-hand goods. [online] Available at:
https://www.saica.co.za/integritax/2004/1188_Second_hand_goods.htm
- Sanderson, H. (2015). Commodities Explained: Metals trading in China. [online] Available at:
<http://www.ft.com/cms/s/2/7553f022-d6fd-11e4-93cb-00144feab7de.html#axzz4LCEFITqb>
- Scharf, K. (2005). Tax Incentives for Extraction and Recycling of Basic Materials in Canada. Fiscal
 Studies, 20(4), pp.451-477.

- Schodde, R. (2011). Recent trends in mineral exploration - are we finding enough ?. [online] Available at: <http://www.minexconsulting.com/publications/Presentation%20on%20Exploration%20to%20RMG%20Conference%20Nov%202011%20FINAL.pdf>
- Scott, M., Dimitrakopoulos, R. and Brown, R. (2002). Valuing regional geoscientific data acquisition programmes: addressing issues of quantification, uncertainty and risk. *Natural Resources Forum*, 26(1), pp.55-68.
- Sinclair Davidson, (2012). Mining Taxes and Subsidies: Official evidence. [online] Available at: http://www.minerals.org.au/file_upload/files/publications/mca_backgrounder_FINAL.pdf
- Söderholm, P. and Tilton, J. (2012). Material efficiency: An economic perspective. *Resources, Conservation and Recycling*, 61, pp.75-82.
- Steenblik, R. (2002). Subsidy Measurement And Classification: Developing A Common Framework. [online] Available at: <http://SUBSIDY MEASUREMENT AND CLASSIFICATION: DEVELOPING A COMMON FRAMEWORK>
- Sunley, E. and Baunsgaard, T. (2001). The Tax Treatment of the Mining Sector: An IMF Perspective. [online] Available at: <http://siteresources.worldbank.org/INTOGMC/Resources/sunley-baunsgaard.pdf>
- The Australia Institute, (2013). Pouring More Fuel on the Fire. [online] Available at: <http://www.tai.org.au/content/pouring-more-fuel-fire>
- Tilton, J. (2004). Determining the optimal tax on mining. *Natural Resources Forum*, 28(2), pp.144-149.
- UK Government, (2016). UK Statistics on Waste. [online] Available at: https://www.gov.uk/government/uploads/system/uploads/attachment_data/file/547427/UK_Statistics_on_Waste_statistical_notice_25_08_16_update__2_.pdf
- UN COMTRADE, (2016). UN Comtrade | International Trade Statistics Database. [online] Available at: <http://comtrade.un.org/>
- UNEP, (2013). Metal Recycling: Opportunities, Limits, Infrastructure. [online] Available at: <http://www.unep.org/resourcepanel/publications/metalrecycling/tabid/106143/default.aspx>
- US EPA, (1994). Federal Disincentives: A Study of Federal Tax Subsidies and Other Programs Affecting Virgin Industries and Recycling. [online] Available at: <https://earthtrack.net/documents/federaldisincentives-study-federal-tax-subsidies-and-other-programs-affecting-virgin-indu>
- USGS, (2012). Estimated Water Requirements for the Conventional Flotation of Copper Ores. [online] Available at: <https://pubs.usgs.gov/of/2012/1089/pdf/ofr2012-1089.pdf>
- USGS, (2016). USGS Minerals Information: Commodity Statistics and Information. [online] Available at: <http://minerals.usgs.gov/minerals/pubs/commodity/>
- Valencia, A. (2007). An econometric study of the world copper industry. [online] Available at: <https://dspace.library.colostate.edu/handle/11124/79515>

- Vial, J. (2004). Modeling Commodity Markets in the Global Economy: Familiar Findings and New Strategies. [online] Available at:
<http://www.ibrarian.net/navon/page.jsp?paperid=1171200&searchTerm=exponential+random+graph>
- Wijkman, A. and Skanberg, K. (2016). The Circular Economy and Benefits for Society. [online] Available at: <http://www.clubofrome.org/wp-content/uploads/2016/03/The-Circular-Economy-and-Benefits-for-Society.pdf>
- World Bank, (2006). Mining Royalties: A Global Study of Their Impact on Investors, Government, and Civil Society. *Int J of Energy Sector Man*, 2(2), pp.297-300.
- World Bank, (2010). Waste Composition. [online] Available at:
<http://siteresources.worldbank.org/INTURBANDEVELOPMENT/Resources/336387-1334852610766/Chap5.pdf>
- World Bank, (2011). Overview of State Ownership in the Global Minerals Industry. [online] Available at:
<http://documents.worldbank.org/curated/en/339551468340825224/pdf/828480NWP0Extr00Box379875B00PUBLIC0.pdf>
- World Bank, (2015). Fossil Fuel Subsidies Approaches and Valuation. [online] Available at:
<http://documents.worldbank.org/curated/en/961661467990086330/pdf/WPS7220.pdf>
- World Bank, (2016a). From Commodity Discovery to Production. [online] Available at:
<https://www.worldbank.org/content/dam/Worldbank/GEP/GEP2016a/Global-Economic-Prospect-2016-January-2016-From-commodity-discovery-to-production.pdf>
- World Bank, (2016b). Mineral rents (% of GDP). [online] Available at:
http://data.worldbank.org/indicator/NY.GDP.MINR.RT.ZS?year_high_desc=false
- World Steel, (2016). Crude Steel Production. [online] Available at:
<https://www.worldsteel.org/statistics/statistics-archive/steel-archive.html>
- WTO, (1999). Agreement On Subsidies And Countervailing Measures. [online] Available at:
https://www.wto.org/english/docs_e/legal_e/24-scm.pdf
- WTO, (2016). WTO analytical index: Guide to WTO Law and Practice - Agreement on Subsidies and Countervailing Measures. [online] Available at:
https://www.wto.org/english/res_e/booksp_e/analytic_index_e/subsidies_01_e.htm
- Zero Waste Europe, (2015). Zero Waste to Landfill: false paths to a Circular Economy. [online] Available at: <http://www.zerowasteurope.eu/downloads/zero-waste-to-landfill-false-paths-to-a-circular-economy/>
- Zink, T., Geyer, R. and Startz, R. (2015). A Market-Based Framework for Quantifying Displaced Production from Recycling or Reuse. *Journal of Industrial*

ANNEX 1. SUPPORT DEFINITIONS FROM INTERGOVERNMENTAL ORGANISATIONS

World Trade Organization

The WTO definition of “subsidies” in its Agreement on Subsidies and Countervailing Measures is the only existing internationally agreed legal definition that covers a broad range of support measures (OECD, 2007). Box 1 provides the text of that definition.

Box 3. Definition of a subsidy in the WTO Agreement on Subsidies and Countervailing Measures

For the purpose of this Agreement, a subsidy shall be deemed to exist if:

(a.1) there is a financial contribution by a government or any public body within the territory of a Member (referred to in this Agreement as “government”), i.e. where:

- (i) a government practice involves a direct transfer of funds (e.g. grants, loans, and equity infusion), potential direct transfers of funds or liabilities (e.g. loan guarantees);
- (ii) government revenue that is otherwise due is foregone or not collected (e.g. fiscal incentives such as tax credits);¹
- (iii) a government provides goods or services other than general infrastructure, or purchases goods;
- (iv) a government makes payments to a funding mechanism, or entrusts or directs a private body to carry out one or more of the type of functions illustrated in (i) to (iii) above which would normally be vested in the government and the practice, in no real sense, differs from practices normally followed by governments; or

(a.2) there is any form of income or price support in the sense of Article XVI of GATT 1994; and

(b) a benefit is thereby conferred.

¹. In accordance with the provisions of Article XVI of GATT of 1994 (Note to Article XVI) and the provisions of Annexes I through III of this Agreement, the exemption of an exported product from duties or taxes borne by the like product when destined for domestic consumption, or the remission of such duties or taxes in amounts not in excess of those which have accrued, shall not be deemed to be a subsidy.

Source : World Trade Organization (1999)

There are several noteworthy exclusions in the WTO subsidy definition (Steenblik, 2002). The first exclusion relates to the provision of government provided general infrastructure, which the WTO considers to be that which ‘is not provided to or for the advantage of only a single entity or limited group of entities, but rather is available to all or nearly all entities’ (WTO, 2016). In the context of the metals industry, the public funding of rural, road and rail networks may significantly reduce the cost of transporting mineral ores and concentrates to market, but be of little relevance for the recycling sector. When such infrastructure serves to benefit one or only a few industries predominantly, subsidies for such infrastructure can be determined to be “specific” for the purposes of a subsidy determination (Steenblik, 2002).

More generally, the WTO definition considers that a subsidy exists (it is “actionable”) only where its benefits are restricted to certain agents. Steenblik (2002) states that, “subsidies that do not favour certain enterprises over others, and which are economic in nature and horizontal in application, such as number of employees or size of enterprise then the subsidies are considered general (and therefore “non-actionable”, i.e. not countervailable)”. In contrast, subsidies are considered specific (and therefore actionable) where they explicitly limit access to the subsidy, either through legislation or government discretion, to a certain enterprise or industry, or groups thereof.

Another exclusion relates to import tariffs and non-tariff barriers. These are excluded from the definition not because they are considered unimportant, but because these measures are addressed separately at the WTO, through market-access negotiations (OECD, 2012).

Finally, the WTO definition states that a subsidy only exists where “there is a financial contribution by a government or any public body” or “any form of income or price support”. In the context of the metals industry, neither of these describe regulatory measures such as mandatory EPR schemes, the effect of which can be to increase the availability and depress the price of scrap feedstock.

The World Bank

Recent World Bank work on support for fossil fuels defined a subsidy as “a deliberate policy action by the government that specifically targets fossil fuels” and either (i) reduces the net cost of energy produced, (ii) reduces the cost of production or delivery of fuels, electricity, or heat, or (iii) increases revenues retained by resource owners or suppliers of fuel, electricity, or heat (World Bank, 2015).

One noteworthy element of this definition is the emphasis placed on “deliberate policy action”, meaning that support exists due to government action, but not necessarily to inaction. This distinction is not unique to the World Bank subsidy definition; it also exists in the conception of support employed by the OECD. In practice, it means that market distortions that result from certain forms of government failure, negligence, or lack of administrative capacity are not necessarily considered to be support. Common examples include lack of enforcement (e.g., electricity stolen from publicly owned utilities) or the non-internalisation of production or consumption externalities.

The Global Subsidies Initiative (GSI)

The Global Subsidies Initiative has worked extensively on quantifying support to biofuels and fossil fuels. One aspect of the GSI subsidy definition is that a policy measure does not have to target a specific sector to be considered as support. That is, a given policy represents support if it confers differential benefits to a particular sector, even if other sectors are eligible to receive the same support. Although this is not necessarily unique to the GSI (the OECD also considers some non-specific policy measures to be support), it is emphasised to a greater extent than by other organisations

One example in the context of this paper relates to measures which artificially lower the cost of energy across the economy. In many jurisdictions, petroleum, diesel, and gas consumption is subsidised; regulated price bands which are maintained through state intervention mean that prices are lower than they would be otherwise (GSI, 2010). In other countries, state owned enterprises – electricity generators or fuel refiners – may elect to supply energy at prices which do not generate normal market returns. These measures are available regardless of sector in most countries, but probably accrue disproportionately to primary metal producers (relative to their secondary equivalents) due to the relative energy intensity of the production process.

The International Monetary Fund (IMF)

The IMF is the only inter-governmental organisation that considers the non-internalisation of production or consumption externalities to represent support. In its recently published report on the magnitude of global fossil fuel subsidies, the IMF counted the societal costs of various externalities associated with fossil fuel combustion, including greenhouse gas and particulate emissions, in its “post-tax subsidy” estimate (IMF, 2015). The underlying assumption is that the damage caused by combustion by-products should be incorporated into the price of the fuel. The externality-related portion of support accounted more than two thirds of the total support available for the energy products considered: coal,

petroleum, natural gas, and electricity. This may have been greater had the environmental externalities associated with upstream fossil fuel production been quantified.

ANNEX 2. EXISTING ASSESSMENTS OF SUPPORT FOR PRIMARY AND SECONDARY METAL PRODUCTION

Primary support

Country level assessments of primary versus secondary support

Sweden: The paper, “Institutional conditions for Swedish metal production: A comparison of subsidies to metal mining and metal recycling” (Johannson et al., 2014), examines the level of Swedish Government subsidies to the primary and secondary metal sector. It finds that the key forms of primary support are: (i) targeted energy tax and carbon tax concessions, (ii) limited capture of resource rents, and (iii) the provision of geo-scientific data. Taken together, these measures were estimated to have conferred around EUR 40 million of support for the Swedish mining sector in 2010. The authors also highlight landfill tax exemptions as a potentially large source of support; mining firms are not required to pay this tax on stockpiled mining waste and tailings whereas recycling firms are required to pay it for recycling residues. If this exemption is considered as support, it would dwarf other measures, representing a EUR 4 billion transfer to mining firms. The authors conclude by saying that, regardless of which definition of subsidy is used, “the mining sector appears to be the beneficiary of a higher rate of subsidies” relative to recyclers.

Canada: The paper, “Tax incentives for extraction and recycling of basic materials in Canada” (Scharf, 1999), examines the overall impact of the Canadian tax system on the incremental cost of producing metal from either virgin or recycled materials. This work begins by establishing the relative capital and labour intensity of primary and secondary metal production. The key result is that metal production from virgin resources is about twice as capital intensive as production from recycled scrap. This, combined with low effective tax rates on capital relative to labour, serves to confer significant support for the primary metal sector. Key tax provisions identified in the study include (i) immediate deductibility of a portion of royalty payments from corporate income tax, and (ii) the immediate deductibility of a portion of exploration and development expenditures from corporate income tax. The authors conclude that the Canadian tax system “significantly favours the use of virgin materials rather than recycled materials in the case of metal products”.

United States: The paper, “A study of federal tax subsidies and other programs affecting virgin industries and recycling” (US EPA, 1994), examined federal tax subsidies for the primary production of virgin sources of metal, energy, timber, and water. It then considered the disincentives to recycling activities that these measures provide. The authors found that the key forms of support for the primary metal sector were (i) percentage depletion allowances, which allow mining firms to deduct a portion of the depleted mineral asset’s value each year, and (ii) federal energy subsidies, which confer differential support for mining firms due to their relative energy intensity. Support conferred to mining firms through percentage depletion allowances was estimated at USD 318 million while that conferred through lower energy prices was estimated at USD 331 million in 1988. The latter form of support represented about 23% of the delivered price of aluminium.

United States: The paper, “Federal energy subsidies and recycling” (Koplow, 1994), examined the support conferred to the aluminium industry through federal energy subsidies. The paper noted that secondary aluminium production using scrap used only 5% of the energy required by primary production, meaning that energy subsidies conferred greater per-unit support for aluminium miners than recyclers. The paper was based on a case study of the Bonneville Power District, which contained around 40% of US primary aluminium production capacity in 1989. Electricity in the district was supplied by a state-owned

generator which was not required to earn market rates of return and which also benefitted from tax breaks and subsidised loans or loan guarantees. Annual support for aluminium smelters in the district was estimated at USD 146 to USD 389 million, or between 5% and 13% of the aluminium market price.

Country-level assessments of primary support

Australia: Two recent country level assessments of support for the mining sector are available for Australia (Griffith, 2013; The Australia Institute, 2013). Both studies highlight the fuel-excise tax rebate – a tax rebate accruing mostly to mining firms – as the largest primary support measure. In 2012, it represented an AUD 2 billion transfer to the mining sector, around half of total quantified support. Other important forms of support included: (i) R&D tax concessions, (ii) prospecting and exploration expenditure deductions, (iii) advanced capital depreciation provisions, (vi) concessionary electricity pricing by SOEs, and (v) the provision of geo-scientific data. The Australia Institute study also suggests that targeted rural infrastructure spending, in the form of the AUD 6 billion Regional Infrastructure Fund, confers indirect support for the mining sector. The objectives for the fund are to: promote development and job creation in mining communities; provide a clear benefit to Australia’s economic development, and invest in Australia’s resource or export capacity; and address potential capacity constraints arising from exports production and resource projects.

Canada: The paper, “An assessment of the value of public support for the metal mining industry in Canada” (Pembina Institute, 2002), documents various forms of support available to primary metal producers in several Canadian provinces and territories. The authors classified support measures according to where in the metal production process they accrued – prospecting and exploration, development and operations, or mine closure and remediation. Total federal and sub-national support for the mining industry in British Columbia, Ontario, Quebec, and the Yukon was estimated at CAD 580 million in 2001. This is reasonably consistent with a nationwide 2002 estimate of CAD 837 million provided in Fothergill (2004). The key support measures identified by the Pembina Institute (2002) mostly operated through the tax system; exploration tax credits, fuel expense tax credits, and corporate income tax holidays all serve to reduce the tax liability of mining firms. Figures provided in the paper indicated that the mining sector at the time faced the lowest effective corporate tax rate – 6% – of any sector in the Canadian economy.

Country-level assessments of a specific primary support measure

A number of studies quantifying support for primary metal production restrict their analysis to a specific jurisdiction, policy instrument (e.g., energy subsidies or below-cost provision of geoscientific data), or commodity (e.g., aluminium). For the purposes of this research, these assessments can be useful because they are undertaken in considerable detail and may also include cross-country comparisons. A selection of such work is presented here:

Africa: The publication, “Breaking the curse, how transparent taxation and fair taxes can turn Africa’s mineral wealth into development” (Lambrechts et al., 2009), examines support provided for the African mining industry via the tax system. This work identifies targeted lower tax rates and exemptions, tax-base erosion through allowable deductions and exemptions, and tax avoidance through individually negotiated mining contracts, as important support measures. An example is provided from Tanzania where, with the exception of AngloGold Ashanti, no mining firm had paid corporate income tax in ten years (mostly due to deductions associated with up-front capital costs).

Australia: Several papers examine the support provided to mining firms through the below-cost provision of geo-scientific data by state or national geological surveys (Scott et al., 2002; Fogarty and Sagerer, 2016). The collection and public provision of these data reduces prospecting and exploration costs for the mining industry. Fogarty and Sagerer (2016) find that the Western Australian government, in

addition to annual geological survey funding of around AUD 25 million, also committed around AUD 15 million per year of exploration drilling subsidies.

China: The paper, “Hidden advantage of Chinese subsidies” (Haley and Haley, 2014), examines the level of Chinese government subsidies to the steel sector. Although this work doesn’t differentiate between support for the primary and secondary sectors, around 90% of Chinese steel production uses Blast Oxygen Furnace technology which relies mostly on primary iron ore for feedstock (Clayton, 2014). The authors find that total energy subsidies to the domestic steel sector between 2000 and 2007 amounted to USD 27 billion. More than 90% of this related to subsidies for thermal and coking coal.

Mining jurisdictions: The paper, “Corporate income taxes, mining royalties, and other mining taxes” (PWC, 2012), summarises the tax exemptions available to mining and processing firms across 22 mining jurisdictions. The report is intended to offer advice to mining firms considering investment in a particular jurisdiction. It provides a particularly useful insight into the importance of different tax measures from the firm’s perspective. Data collated in the study focus on several aspects of tax policy including: (i) the tax treatment of capital assets, (ii) royalty payments and mineral taxes – the base and rate on which they are assessed, and (iii) withholding tax rates on dividend, interest, royalty, and service payments.

OECD and other countries: The OECD environmental tax database (OECD, 2016b) is an inventory of environmental taxes applied in 57 OECD and other countries. The database provides information on revenues raised, the tax-base covered, tax rates applied, and important exemptions and refund mechanisms. The latter data are particularly relevant for primary support – fuel excise tax refunds and exemptions targeted at mining operations are identified in Australia, Argentina, Sweden, and various Canadian provinces and territories. Fuel and electricity tax refunds and exemptions targeting metallurgical smelting and refining facilities are noted in Estonia, Ireland, Netherlands, Norway, Portugal, Slovenia, Spain, and Sweden. The magnitude of foregone tax expenditures associated with these provisions is not available.

Global: The paper, “Export restrictions in raw materials trade: facts, fallacies and better practices” (OECD, 2014), documents and examines the effects of export restrictions on primary metals, scrap, wood, and agricultural commodities. One key finding is that export restrictions on mineral ores or relatively unprocessed materials can confer support for domestic downstream processing facilities, which benefit from lower feedstock prices. Of the 72 countries surveyed, only 12 did not apply any restriction on the export of the raw materials between 2009 and 2012. The most frequently used policy measures in the primary metals sector are export taxes and licensing requirements, which represented 39% and 47% of all documented export restrictions. Export restrictions were most prevalent for technology-related metals – more than half of niobium, tantalum, and vanadium exports were subject to some form of restriction in 2012. Trade measures are discussed further in Chapter 5.

Secondary support

Specific secondary support measures: green taxation

OECD Countries: The OECD environmental tax database (OECD, 2016b) is an inventory of environmental taxes applied in 57 OECD and other countries. The database provides information on revenues raised, the tax-base covered, tax rates applied, and important exemptions and refund mechanisms. In the context of support for secondary metal production, information on specific resource and landfill taxes are particularly relevant because these influence the relative market prices of virgin and recycled feedstock. Data on tax rates applied to energy and water use are also noteworthy since secondary metal production uses these inputs relatively sparingly. Jurisdictions where these inputs are taxed relatively highly may be able to be identified.

Major Economies: The KPMG green tax index (KPMG, 2013) documents tax breaks and other incentives targeted at ‘green’ industries. The geographical focus is mostly OECD countries, although data for Russia, Brazil, and South Africa is also presented. Tax incentives of particular interest include green specific accelerated depreciation or tax deductions for investment in environmental facilities, specific tax deductions or credits for environmentally related R&D, and VAT and other tax exemptions for secondary sector activities. There is a section dedicated to support for material resource efficiency and waste management. Subsidy sizes are not presented but links to relevant source material are made available.

Europe: The paper, “Overview of the use of landfill taxes in Europe” (ETC/SCP, 2012), provides a summary of landfill tax rates and collected revenues across 20 European countries. Revenues collected through landfill taxes amounted to EUR 2.1 billion in financial year 2009/2010, but there was significant variation across countries due to differential tax rates and waste disposal.

Global: The paper, “Export restrictions in raw materials trade: facts, fallacies and better practices” (OECD, 2014), documents and examines the impacts of export restrictions on primary metals, scrap, wood, and agricultural commodities. In the context of the metals industry, one key finding is that export restrictions on metal scrap can confer support for domestic downstream processing facilities, which benefit from lower feedstock prices. Of the 72 countries surveyed, only 12 did not apply any restriction on the export of raw materials between 2009 and 2012. The most frequently used policy measures in the secondary metals sector are export bans, export taxes, and licensing requirements, which represented more than 90% of all documented export restrictions. Trade measures are further discussed in chapter 5.

ANNEX 3. CONSIDERATIONS FOR FUTURE WORK: QUANTIFICATION OF SUPPORT FOR THE METALS SECTOR

Support for the production of metal is common in both the primary (extractive) and secondary (recycling) sectors. A number of assessments have been undertaken for specific countries (Scharf, 1999; Griffith, 2013; Johansson et al. 2014), support measures (Lambrechts et al., 2009; OECD, 2014; Fogarty and Sagerer, 2016), and commodities (OECD, 2008; OECD, 2015). However, there is currently no comprehensive cross-country assessment of support that covers a broad set of measures and commodities. This is in contrast to environmentally harmful subsidies (EHS) provided to other sectors; detailed assessments exist for agriculture, fisheries, and energy.

The environmental effects of mineral extraction and processing are well documented (see section 6.3). Surface disruptions associated with mining activity can have adverse consequences for habitat preservation and the quality of local ground and surface water. Beneficiation and processing of extracted ores requires considerable amounts of energy and water inputs, and generates an array of often toxic waste products: tailings, greenhouse gas emissions, particulate emissions, and smelter slimes. Support for mining and mineral processing firms, to the extent that it results in additional production from the sector, serves to increase these impacts.

There are two main reasons why developing a cross-country assessment of support to the metals sector would be worthwhile. First, it would increase transparency on the various mechanisms that governments use to provide support to metals firms. Questions such as, what is the relative magnitude of support provided across countries, which support measures are most important, and to what extent does the secondary sector also benefit, could be better addressed. Second, the data created during such an assessment would facilitate analyses of the economic impacts of support. Questions such as, how responsive is metal output to the provision of support, could potentially be addressed.

This Annex outlines the various approaches that could improve the stock of knowledge on support for the metals sector. It highlights three main options, each with various strengths and weaknesses. Option 1, involving the development of a small number of detailed case studies, building on those by Griffith (2013) and Johansson et al. (2014), would provide additional insights for the selected countries, but would be far from a comprehensive overview of support. Option 2, involving the development of a qualitative inventory, would improve transparency on the relative frequency of different support measures while improving the visibility of measures that are difficult to quantify. It would be of limited use for quantitative analytical purposes however. Option 3, involving a full quantitative inventory of support (in the manner of the OECD inventory of support for fossil fuels), is the most comprehensive but would also require considerable resources.

Quantifying support: lessons from past experience

Considerable effort has been made to establish the value of various environmentally harmful subsidies (EHS) during recent decades. Assessments of support have been made for several sectors, including agriculture, energy, and fisheries. There is now a large stock of expertise on how to best undertake support estimates, and best practice manuals have been published by several practitioners (OECD, 2016; GSI, 2016). Many of the lessons learned in other sectors will be of direct relevance for the metals; this section

highlights several of these in the context of the two main tools used to estimate support – the price gap and inventory methods.

Price gap method

The price gap method involves using price data to establish any divergence between a domestic commodity price of interest and its international benchmark. This divergence, multiplied by domestic sales volumes, is then taken as an estimate of the magnitude of support to the product or sector of interest. The price gap method has been used by the IEA and the IMF to estimate consumer support for fossil fuels, and by the OECD for producer support for agriculture; additional information on the method can be found in the associated publications (IEA, 2016; IMF, 2015; OECD, 2016).

One key advantage of the method is that it allows consistent estimates of support to be made across multiple countries quickly and on the basis of readily available data. This simplicity allows support estimates to be updated regularly, and the value of support to be tracked through time. In addition, price gaps can also provide useful insights into the existence and magnitude of support in certain countries that lack the capability or will to provide accurate information on metals-related government activities (e.g., Koplow, 2009).

There are also limitations (e.g., Wise, 2004; Koplow, 2009). First, the method only captures support measures which are reflected in lower domestic consumer price, which may not always be the case. Transfers to upstream producers are not generally fully transferred along supply chains, and interacting tax policies may partially mask the effect that support measures have on consumer prices. For this reason, support estimates made using this method are often considered to represent a lower bound. Second, as stated in the OECD Companion to the Inventory of Support Measures for Fossil Fuels, “by focussing on the symptoms rather than on the disease, price-gap estimates do not provide information on the entire suite of policies and regulations that actually cause domestic fuel prices to fall below international reference prices”.

Inventory method

The other main approach to subsidy estimation – the transfer or inventory method – involves calculating the total value of support from the bottom up, on a measure by measure basis. This can either be done directly, on the basis of information contained in official government financial statements (e.g., budget or tax expenditure statements), or indirectly, by using alternative datasets to estimate the value of support. The inventory method has been used extensively by the OECD to estimate support for agriculture (OECD, 2016), fossil fuels (OECD, 2015), and fisheries (OECD, 2015), and by the Global Subsidies Initiative for fossil fuels (Global Subsidies Initiative, 2016).

The key advantage of the method is the additional insight it provides; that source, size, and recipients of individual support measures can be identified, as well as where in the value chain support is accumulating. This information is useful both as an entry point for subsidy reform (Koplow, 2009), and as a basis for empirical analysis of the economic and environmental impacts of support. However, it comes at the cost of a far greater primary research requirement, which is perhaps one reason why the price gap method has traditionally been used for cross country comparisons of support size.

The typology of support measures presented in Chapter 2 distinguishes between five types of transfer mechanism: direct transfers of funds, foregone tax revenues, other foregone revenues, risk transfers to government, and induced transfers. In practice, quantification of the latter three types of transfer is difficult using the inventory method; most existing assessments focus on direct transfers of funds and foregone tax revenues. This is largely due to data constraints; government budget and tax expenditure

statements generally contain some data on the value of these types of transfer, but rarely detail the size of others. As such, the magnitude of support provided through concessionary public investment finance, sovereign credit guarantees, operating transfers to sub-economic state-owned enterprises, or sub-optimal resource pricing often remains opaque. These transfers generally have to be estimated from first principles, which is both time intensive and analytically demanding.

Even establishing the value of direct transfers of funds and foregone tax revenues can be challenging. For example, the level of disaggregation that budget, tax expenditure, and other public financial statements are published at varies across countries. In many cases, the available information does not allow the value of support to be clearly allocated to a particular industry, sector, or commodity of interest; additional assumptions are required to do so. There are also particular issues relevant for tax expenditure statements. First, although almost all OECD countries regularly publish these at the national level (EC, 2014; OECD, 2013), this is not necessarily the case for other countries, or for sub-national jurisdictions in which taxation is levied. Second, tax expenditure statements generally provide detailed information for personal and corporate taxes, but not necessarily for VAT, excise, and resource taxes.

Quantifying support: considerations for the metals sector

In addition to the general issues identified above, there are a number of issues of particular relevance for estimating support to the metals sector. This section provides a brief summary of these.

Support in the metal sector is dominated by transfers to producers

Government support for the metals sector is mostly incident on production. This is in contrast to the energy sector, where controls or mandates on the consumer prices of certain fuels or electricity are quite common. One possible explanation for this distinction relates to different consumption patterns; almost all demand for refined metal is associated with intermediate demand from manufacturers rather than from final consumption. In addition, there are likely to be fewer equity considerations with metals because they are not viewed as being an essential good in the same way that energy is.

Support for metal production is provided through a large variety of measures, but direct market price support such as that documented in other sectors (e.g., agriculture) is largely unknown. Price support that is induced by tariffs and associated non-tariff barriers may be more relevant. World Bank data indicate that the average most-favoured-nation (MFN) tariff rates for finished metals and mineral ores and concentrates were 6.6% and 4.1% 2015 (WITS, 2016). Tariffs on finished metals are especially notable; MFN rates of up to 10% are applied to certain refined products in a number of important metal producing countries (WTO, 2016)

The general absence of measures that directly affect the price of finished metals has implications for which method is best suited to quantifying support in the sector. While the price gap method has been used widely elsewhere, it may be less appropriate for sectors, like metals, in which most support is received directly by producers. Transfers received upstream may not necessarily be fully passed along the value chain, and without domestic price controls or trade restrictions, domestic and international prices will tend to equilibrate with the result that no price gap exists. The use of price gaps in this context would at best provide a lower bound estimate of the magnitude of support method, and at worst give the misleading impression that no support was being provided.

The OECD Inventory of Support Measures for Fossil Fuels utilises the inventory method partly in order to address the above issues. Quantifying support on a measure by measure basis allows the value of transfers to producers to be accurately captured, even in situations where support doesn't necessarily translate into lower domestic, or international, consumer prices. This is feasible where support is only

available for a small proportion of production, or where a lack of competition allows producers to retain, rather than passing on, transfers. Such support may still have important environmental consequences if it serves to prolong the operations of firms which would otherwise be forced to exit the market.

Support in the metals sector often originates at sub-national levels of government

Although this is not unique to the metals sector, support provided by state, provincial, and local governments is perhaps more common than in other sectors. There are two main reasons for this. First, state or provincial governments are responsible for developing the mineral royalty regime in many important mining countries (e.g., Australia and Canada). Any available exemptions or deductions to the royalty regime are therefore a product of sub-national decision making. Second, policies and regulations relating to waste management activities are almost always devolved to the state, provincial, or local government in OECD countries. The amount of financial assistance available to recycling operations, the waste management services that are provided, and the magnitude of landfill taxes therefore vary across sub-national jurisdictions.

This has important implications for quantifying support in the sector. Compiling a comprehensive national level estimate of total support for either primary or secondary metal production would require considerable time assessing public financial statements at the sub-national level. The effort required will vary with the governance structure of a country; quantifying support in countries with greater devolution of power will be relatively more time consuming.

Support in the secondary sector may be difficult to quantify: the case of induced transfers

Transfers induced by various government policies and regulations are common in the secondary metals sector. Extended Producer Responsibility schemes, landfill taxes, and the municipal provision of separated recycling collection all serve to increase the supply of scrap feedstock. In certain countries, where trade restrictions limit cross border shipments of potentially hazardous materials, this can lead to downward pressure on domestic scrap prices, with resulting transfers to secondary metal processing facilities. In a similar way, demand side policies such as mandated labelling of recycling content and public procurement policies tend to increase demand for “green” products, which potentially increases the market share of secondary smelters.

Quantifying the value of induced transfers is difficult because it is necessary to determine the changes in the prices of the inputs and outputs facing the sector. A well calibrated computerised economic model may be a minimum requirement for analysing this, but in practice very few studies have attempted this in any detail. In particular, there is usually a difference between the net cost of a support measure (for governments) and its net benefits (for recipient firms). In the case of landfill taxes, the net cost for governments is actually negative (public revenues are generated), while the net benefits conferred to recycling firms is difficult to quantify; these depend on changes in scrap feedstock supply and prices.

Support in the metals sector is likely to accumulate unevenly across different metals

Although this is not unique to the metals sector, there are good reasons for trying to document support on a metal by metal basis. In terms of developing transparency, support for metals may be of greater concern if most of it accrues mostly to scarce or environmentally burdening metals. There are also implications for assessing the impact that support has on the relative competitiveness of primary and secondary production. Competition between the two sectors takes place on a metal-by-metal basis; iron ore producers do not generally compete with copper recyclers. If the goal of developing an inventory of support in the metals sector is to enable a quantitative analysis of market distortions resulting from support,

then individual transfers should be estimated on a metal by metal basis. Doing so may not be possible in all cases.

In most cases, government financial statements break down the value of direct outlays and tax expenditures by sector or industry. Disaggregation by metal is unknown, and as such, allocating the value of individual support measures across different metals would require making certain additional assumptions. These would largely involve accounting for the variable proportion of different metals in total output across countries.

There are additional issues for quantifying support to the secondary sector. In particular, measures which serve to increase the amount and quality of materials emerging from the municipal solid waste stream probably create significant value for recyclers. Quantification is complicated because landfill taxes and the provision of municipal waste and recycling collection services affect the entire waste stream, of which metals only represent a small proportion (see Section 1.3.2.2). Any estimates of secondary support provided through the municipal waste stream will be overestimates if metal content is not accounted for.

Primary metal production is greater than the secondary equivalent: assessing the relative magnitude of support requires support be estimated in per-unit terms

Establishing the magnitude of support on a country by country basis for either the primary or secondary metals sectors would be a worthwhile exercise in itself. However, any meaningful comparison of support between the two sectors requires that support be considered in per-unit terms; global metal production from mining is significantly larger than that from recycling. Data presented in Chapter 1 showed that, at the global level, primary production of finished steel, aluminium, and copper is around three times greater than the secondary equivalent. The ratio is likely to be considerably larger for relatively infrequently recycled elements such as the REEs.

The average subsidy rate measures the relative amount of support given to an industry while controlling for its size (OECD, 2016a). In the context of the metals sector, this means that total quantified support must be divided by the value of total production. This calculation should ideally be undertaken at each stage of the production chain; using the value of total finished domestic metal production will produce a biased estimate of the average subsidy rate in countries with significant trade in intermediate metal products. Unfortunately, quantifying support provided at different points in the value chain may be challenging due to the consolidated character of government budget documents.

Estimating total support – the numerator in the average subsidy rate equation – within a given jurisdiction is hampered by normal support quantification difficulties (Steenblik, 2002, OECD, 2015b; GSI, 2010) as well as the metal-specific ones highlighted in this section. Estimating the total value of production – the denominator in the equation – can also be difficult. Few countries host full primary or secondary metal supply chains. The value of metal production varies according to whether upstream, intermediate, or finished production is considered. Parts of the primary or secondary metal value chain may be poorly developed or entirely absent. Many countries lack an upstream mining sector while others may have poorly developed recycling infrastructure or lack downstream primary or secondary smelting facilities. Countries commonly import finished metal products, intermediate metals or secondary scrap.

Quantifying the value of support in the metals sector: what is feasible?

General considerations

There is a clear knowledge gap concerning the types and value of support available for metal production and consumption. Although there are some instructive publications on the subject (see Sections 3.2 and 4.2), the scope of these is generally restricted to a particular country, sector, or type of support

measure. In contrast to several other potentially environmentally harmful sectors (e.g., agriculture, fossil fuels, fisheries), there is no comprehensive cross-country database of government support available for the metals sector. This is perhaps surprising given the relevance of minerals and metals to circular economy efforts.

This section outlines three possible options for advancing the current stock of knowledge on support for the metals sector (table 11). From less to greater levels of ambition, these are:

- Individual country case studies: document, and quantify wherever possible, all relevant support measures within a sub-set of countries. Examples of such an exercise have been undertaken within the fossil fuel sector in the context of the G20 and APEC peer review processes
- Qualitative cross-country inventory: document all relevant support policies across a broader set of countries, perhaps including OECD members and key partners, along with other important metal producing jurisdictions. One existing example of such an exercise is provided by OECD work on support for the steel sector (OECD, 2008)
- Quantitative cross-country inventory: quantify a sub-set of support policies within OECD members, key partners, and other important metal producing countries. The OECD Inventory of Support Measures for Fossil Fuels represents one example of such an exercise (OECD, 2015)

Proposed options for future work

		<i>Increasing ambition</i>		
		Selected case studies	Qualitative inventory	Quantitative inventory
Country coverage		Limited	OECD + partners	Discretionary
Primary and secondary coverage		Discretionary	Discretionary	Discretionary
Temporal coverage		Discretionary	Discretionary	Discretionary
Commodity disaggregation?		Possibly	Yes	Possibly
Monetary estimates		Yes	No	Yes
Policy coverage	Budgetary transfers	Yes	Yes	Yes
	Foregone tax revenue	Yes	Yes	Yes
	Other foregone revenue	Possibly	Yes	No
	Transfer of risk	Possibly	Yes	No
	Induced transfers	No	Yes	No

Source: Own compilation

The most appropriate course of action will depend on both the resources that can be mobilised for the work, and the applications that the data is expected to be used for. If the main intention is to raise awareness around the magnitude of support for primary metal production, then a series of case studies in important metal producing countries may suffice. Introducing support for secondary production to the analysis would be required if the goal is to establish the relative magnitude of support for the primary and

secondary sectors. Finally, more detailed data collection would be worthwhile if the database was expected to become the basis for an empirical analysis on the effects of support. In that case, additional temporal coverage and disaggregation of the value of support measures by recipient metal would be recommended.

One key consideration is whether the relative level of support for primary and secondary metal production should be assessed. Such a comparison has received relatively little attention in other sectors (e.g., fisheries and agriculture). It is perhaps of greater relevance in the metals sector, particularly in the context of increased interest in a more circular economy. Secondary metals are highly substitutable for their primary equivalents in many applications, and the degree to which the two sectors compete on even terms is therefore of some interest. Establishing the relative level of support for primary and secondary production would require the universe of secondary support measures to be considered. This would involve considerable effort documenting support provided at the sub-national level of government.

It is worth emphasising that several common forms of support for primary and secondary metal production will not be easily quantified. Data constraints will make it difficult to estimate the value of support provided via the public provision of concessionary investment finance and the sub-economic operation of SOEs. The problem is even worse for induced transfers (such as those related to waste management policy) and transfers created through undercharging for access to sovereign resources; there are no accepted methodologies available for estimating the value of these types of transfer. For example, resource royalty or tax rates vary considerably across different mining jurisdictions, and part of this variation is probably due to strategic undercharging in order to attract international mining investment. The problem (with respect to quantification) is that much of this variation is also explained by interactions with other forms of taxation (e.g., corporate income taxes), and by variations in resource quality across jurisdictions. In short, the appropriate baseline required for estimating this type of support is unclear.

Approach #1: country case studies

This would involve making detailed assessments of support for primary and secondary metal production in a small number of producer countries. It would build on several existing case studies which have been undertaken for primary metal production in Australia (Griffith, 2013) and primary and secondary production in Sweden (Johansson et al. 2013). Individual support measures would be documented according to the typology presented in this paper and, wherever possible, quantified. The net result would be an improved understanding of the relative magnitude of support for primary and secondary metal production in the countries of interest.

One major advantage of this approach relates to required resources; limiting the assessment to a small subset of countries would allow the work to be carried out quickly. In addition, relative to a full quantitative inventory, additional attention could be directed to forms of support that are often difficult to quantify. For example, estimating the value of transfers created by the public provision of concessionary investment finance would provide a useful insight into the importance of such policies. There is an established methodology for quantifying such measures (see Lucas, 2013, Lucas, 2015), but applying it in an exhaustive way across many countries would be extremely time consuming. Another example relates to secondary support which, as discussed in section 7.3.2, is often provided by state or provincial governments. Estimating the value of these measures for a subset of countries would establish their likely importance without requiring excessive resources.

Limiting the assessment to a small subset of countries would raise the question of which countries. Targeting the analysis towards countries with large proportions of world market share (Figure 27), or with significant volumes of high cost production, would probably be warranted. Support is more likely to impact market conditions in these scenarios, with associated consequences for the competitiveness of the

fringe secondary sector. The potentially large distortionary effect of support in high cost jurisdictions was well demonstrated in a recent study of the oil and gas industry in the United States (SEI, 2016). This work focussed largely on high cost shale production, and found that, at current oil prices (USD 50/barrel), around half of known but undeveloped resources would be uneconomic without current subsidies.

Largest upstream (top) and downstream (bottom) iron, aluminium, and copper producers

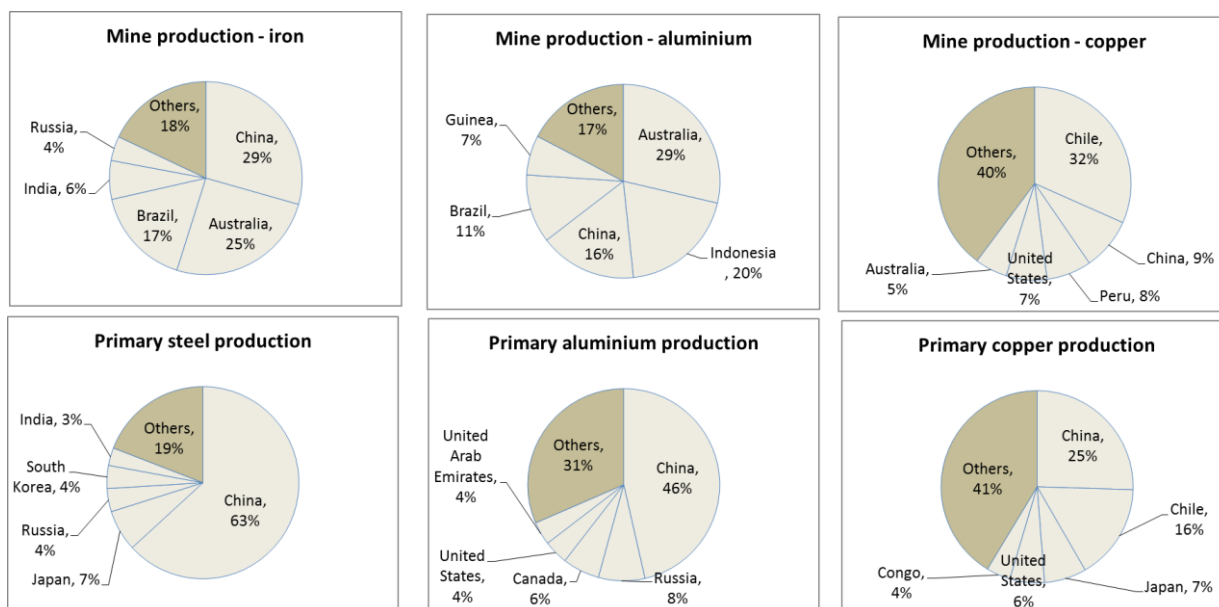

Source: USGS, 2016

One obvious corollary of only considering a handful of countries is the potential for an unbalanced picture of support to emerge. It would therefore be important to include the full diversity of producer countries, including those (i) spanning the entire supply chain (i.e., including jurisdictions without domestic mineral resources but with considerable processing capacity), (ii) with advanced and emerging economies, (iii) specialising in different metals, and (iv) with dominant primary sectors (and vice versa). This would increase the robustness of the resulting findings on the magnitude of support for primary and secondary metal production.

Approach #2: qualitative inventory of support measures

This option represents a sort of middle ground between a case study approach and a full quantitative inventory of support (see below). It would involve documenting support measures that are available for primary and/or secondary metal production; the focus would not be on quantification, but rather on systematically establishing what the most common forms of support are. Geographical coverage would ultimately be determined by available funding, but would ideally include OECD members, key partners, and any other important producer countries. The main outcome would be improved transparency on the most common mechanisms that governments use to provide support for the metals sector in various countries.

There are two main advantages to this approach. First, a qualitative analysis would provide greater visibility for forms of support that are difficult to quantify. This is potentially important in the context of the metals sector where methodological (foregone resource rents) and data (limited availability of financial data for SOEs, provision of secondary support at sub-national levels of government) issues serve to limit quantification. Second, restricting data collection to the presence or absence of various forms of support,

rather than quantifying them, would allow increased country coverage for a given amount of funding. In the event that additional funding became available, the resulting qualitative inventory would represent an ideal stepping stone towards a more comprehensive quantitative inventory.

The major drawback of developing a qualitative inventory relates to the limited conclusions that could be drawn. It would not be possible to answer questions such as “what is the relative magnitude of support for primary production in country X and country Y” or “does the primary metals sector receive a disproportionately large amount of support relative to the secondary equivalent”. That said, answering such questions on the basis of a more quantitative approach wouldn’t necessarily be straightforward either. As discussed above, there are several reasons why potentially important forms of support for metal production will be difficult to quantify.

Approach #3: quantitative inventory of support

This is the most comprehensive approach described here. It involves the same methodology as that proposed for the case studies, but applied to a much broader set of countries. The OECD Inventory of Support Measures for Fossil Fuels provides a useful illustration of what such an inventory approach would involve, and the insights that it could provide. An optional extension that could be made in the metals case is inclusion of support for the secondary sector. The net result would then be an in-depth understanding of the types and value of support provided to both the primary and secondary metal sectors within all major metal producing countries.

The chief advantages of a quantitative inventory relative to the alternative two approaches are clear. Quantification and greater country coverage would increase the robustness of resulting conclusions on the magnitude of support to the metals sector, and would also provide a better dataset with which to conduct empirical analyses. The main drawback of this approach is also straightforward. The funding and resources required to develop such an inventory would be considerable.