

Unclassified

DSTI/DOT/RTR/IR6(98)1/FINAL



Organisation de Coopération et de Développement Economiques  
Organisation for Economic Co-operation and Development

OLIS : 26-Oct-1998  
Dist. : 27-Oct-1998

Or. Eng.

DIRECTORATE FOR SCIENCE, TECHNOLOGY AND INDUSTRY  
PROGRAMME OF CO-OPERATION IN THE FIELD OF RESEARCH ON ROAD TRANSPORT AND  
INTERMODAL LINKAGES

Scientific Expert Group IR6 on the Dynamic Interaction between Vehicles and  
Infrastructure Experiment (DIVINE project)

DYNAMIC INTERACTION BETWEEN VEHICLES AND  
INFRASTRUCTURE EXPERIMENT (DIVINE)

TECHNICAL REPORT

71048

Document complet disponible sur OLIS dans son format d'origine  
Complete document available on OLIS in its original format

DSTI/DOT/RTR/IR6(98)1/FINAL  
Unclassified

Or. Eng.

**Copyright OECD, 1998**

**Applications for permission to reproduce or translate all or part of this material should be made to:  
Head of Publications Service, OECD, 2 Rue André Pascal, 75775 Paris Cedex 16, France.**

## FOREWORD

The Road Transport and Intermodal Linkages Research Programme (RTR) is a co-operative approach among Member countries to address technical, economic and policy issues relevant to safe and efficient road transport. The Programme, through its broader linkages to other modes, reflects a multimodal approach to common transport problems and represents a combined attempt to reduce the negative impact of transport on the environment. The Programme has two main fields of activity:

- international research and policy assessments of road and road transport issues to provide analytical support for decisions by Member governments and international governmental organisations;
- technology transfer and information exchange through two databases -- the International Road Research Documentation (IRRD) scheme and the International Road Traffic and Accident Database (IRTAD).

Its mission is to:

- enhance innovative research through international co-operation and networking;
- undertake joint policy analyses and prepare technology reviews of critical road transport issues;
- promote the exchange of economic, scientific and technical information in the transport sector and contribute to road technology transfer in OECD Member and non-member countries;
- promote the development of sound policies to achieve a safe and efficient transport sector that is responsive to the environment.

The activities concern:

- sustainable multimodal transport strategies;
- economic performance, transport infrastructure and management;
- transport safety and environment.

**ABSTRACT**

**IRRD NO. 899920**

The Dynamic Interaction between Vehicles and Infrastructure Experiment (DIVINE) Project provides scientific evidence of the dynamic effects of heavy vehicles and their suspension systems on pavements and bridges in support of transport policy decisions that affect infrastructure and road freight transport costs. It follows a 1992 OECD Expert Group which recommended international research co-operation aimed at determining the true significance of vehicle dynamics for pavement life and costs and at providing vehicle assessment methods. Six separate Research Elements were established in DIVINE to investigate all aspects of vehicle-infrastructure interaction. In total, 17 countries and the European Commission contributed to the research project. The policy implications of the research findings are discussed in a separate report, *Dynamic Interaction between Vehicles and Infrastructure Experiment: Policy Implications* (pending). This technical report concludes that pavement wear under steel suspensions is at least 15 per cent faster than under air suspensions and that the concentration of dynamic loads for air suspensions is only about half the magnitude of that for steel suspensions. It shows that road simulators can replicate dynamic wheel loads measured on the road. The report identifies the essential properties of road-friendly suspensions as low spring stiffness, very low Coulomb friction and an appropriate level of viscous damping. Such properties are to be found in well-designed and well-maintained air suspensions and it is unlikely that steel spring suspensions could achieve the desired level of performance. The report also reveals that the surface profile of a bridge and its approaches are fundamental to the response of the truck suspension and in turn the dynamic response of the bridge. For a smooth profile, the influence of the truck suspension is insignificant; its importance increases as the unevenness of the profile increases.

Field Classification: pavement design  
design of bridges and retaining walls  
construction of bridges and retaining walls

Field Codes: 22, 24, 53

Key Words: pavement design; pavement; axle load; dynamics; wear; damage; simulation; digital computer; lorry; suspension (veh); bridge; OECD; deformation; test method

## TABLE OF CONTENTS

FOREWORD.....	3
ABSTRACT .....	4
EXECUTIVE SUMMARY .....	9
CHAPTER I. INTRODUCTION.....	15
I.1 Purpose of the Project.....	15
I.2 The interaction between freight vehicles and infrastructure: socio-economic factors .....	15
I.3 Organisation and management of the DIVINE Project .....	16
I.3.1 Scientific approach developed by the OECD .....	16
I.3.2 Organisational structure of the Project .....	17
I.3.3 Funding of the DIVINE Project.....	17
I.3.4 Review procedures.....	19
I.4 Brief details of the DIVINE Project .....	19
I.4.1 Objectives of the Project.....	19
I.4.2 DIVINE research aims .....	21
I.5 Presentation of results .....	22
I.5.1 Practical findings for implementation .....	22
I.5.2 Findings for advancing scientific knowledge .....	22
I.5.3 Structure of the Final Technical Report.....	23
I.6 Significance of the DIVINE Project.....	24
BIBLIOGRAPHY.....	24
CHAPTER II. THE ORIGINS OF THE DIVINE PROJECT.....	26
II.1 Economic and regulatory issues.....	26
II.1.1 Background.....	26
II.1.2 Reducing road costs.....	27
II.1.3 Reducing user costs .....	27
II.1.4 Legislation for road-friendly vehicles .....	30
II.1.5 Survey of key technical issues in policy formulation .....	30
II.2 Scientific basis of the DIVINE Project .....	32
II.2.1 Background.....	32
II.2.2 Dynamic loading of pavements and bridges .....	33
II.2.3. Pavement structural design procedures .....	40
II.2.4. Life-cycle costing .....	41
II.2.5 Influence of pavement non-uniformity -- Methods of analysis .....	42
BIBLIOGRAPHY.....	44

CHAPTER III. THE VEHICLE-INFRASTRUCTURE SYSTEM: A NEW APPROACH.....	45
III.1 Introduction.....	45
III.2 System components .....	46
III.2.1 Pavements .....	46
III.2.2 Bridges .....	46
III.2.3 Vehicles .....	47
III.3 Principal system characteristics .....	48
III.3.1 Longitudinal pavement profile .....	48
III.3.2 Dynamic wheel forces .....	49
III.3.3 Vehicle acceleration .....	49
III.3.4 Pavement and bridge strains/deflections .....	49
III.3.5 Pavement modulus and bridge stiffness .....	50
III.3.6 Pavement distress .....	50
III.3.7 Bridge fundamental natural frequency and associated damping .....	50
III.4 Conceptual models.....	51
III.4.1 Vehicle-pavement interaction .....	51
III.4.2 Vehicle-bridge interaction.....	51
III.5 The DIVINE Project and its Research Elements .....	55
III.5.1 Element 1: Accelerated dynamic pavement test .....	55
III.5.2 Element 2: Pavement primary response testing .....	56
III.5.3 Element 3: Road simulator testing .....	56
III.5.4 Element 4: Computer simulation of heavy vehicle dynamics .....	57
III.5.5 Element 5: Spatial repeatability of dynamic loads .....	57
III.5.6 Element 6: Bridge dynamic loads .....	58
III.5.7 Summary of the DIVINE Project.....	58
BIBLIOGRAPHY.....	60
CHAPTER IV. THE PERFORMANCE OF THE VEHICLE-INFRASTRUCTURE SYSTEM: FINDINGS OF THE DIVINE PROJECT .....	61
IV.1 Infrastructure response to vehicles .....	61
IV.1.1 Pavement primary response and dynamic loading -- Details of Element 2 research .....	63
IV.1.2 Pavement dynamic loading and spatial repeatability -- Details of Element 5 research .....	68
IV.1.3 Bridge response -- Details of Element 6 research.....	76
IV.2 Vehicle suspension effects on pavement condition and performance .....	81
IV.2.1 Details of test conditions.....	81
IV.2.2 Summarised comparison of suspension effects .....	82
IV.2.3 Implications for suspension effects on highway pavements .....	85
IV.3 Vehicle assessment for “road-friendliness” .....	90
IV.3.1 The EC drop test .....	91
IV.3.2 Vehicle testing .....	92
IV.3.3 Evaluation of computer models .....	101
IV.3.4 Suspension properties for road-friendliness .....	106
IV.3.5 Evaluating suspension performance .....	109
BIBLIOGRAPHY.....	110

CHAPTER V. IMPROVING THE VEHICLE-INFRASTRUCTURE SYSTEM: IMPLICATIONS OF THE DIVINE RESEARCH.....	112
V.1 Pavements .....	112
V.1.1 Pavement response to vehicles .....	113
V.1.2 Pavement design and performance.....	115
V.1.3 Concepts of pavement life and performance.....	117
V.2 Bridges .....	118
V.2.1 Bridge response to dynamic wheel loads .....	119
V.2.2 Summary .....	120
V.3 Vehicles.....	121
V.3.1 Current air and steel suspensions .....	122
V.3.2 Suspension performance requirements .....	123
V.3.3 Assessing vehicles for road-friendliness .....	123
V.3.4 Road simulators .....	123
V.3.5 Computer simulation models .....	124
V.3.6 Performance under extreme conditions of road roughness .....	124
V.3.7 Implementation of suspension performance standards .....	124
V.4 Research needs.....	124
V.4.1 To what extent did the DIVINE project meet its objectives? .....	124
V.4.2 What research is needed to further improve the relationship between heavy vehicles and the infrastructure? .....	126
V.4.3 How can improved knowledge of the physical interactions lead to practical models of costs to road providers as well as road users? .....	128
V.5 Summary findings .....	129
ANNEX A TERMINOLOGY AND BRIEF OVERVIEW OF PAVEMENT DESIGN, PAVEMENT CONDITION ANALYSIS AND BRIDGE DESIGN .....	131
A.1 Terminology.....	131
A.1.1 Pavement primary response .....	131
A.1.2 Damage.....	131
A.1.3 Distress .....	131
A.1.4 Pavement wear .....	131
A.2 Development of pavement structural design procedures .....	132
A.2.1 Empirical design.....	132
A.2.2 AASHO Road Test.....	132
A.2.3 Mechanistic design .....	133
A.2.4 Accelerated pavement testing.....	134
A.3 Development of pavement condition analysis procedures .....	136
A.4 Development of bridge design with regard to dynamic loading .....	137
BIBLIOGRAPHY.....	138
ANNEX B FACILITIES AND EQUIPMENT USED .....	140
B.1 The Canterbury Accelerated Pavement Testing Indoor Facility (CAPTIF) .....	140
B.2 DIVINE test roads .....	141
B.2.1 Virttaa test site (Finland) .....	141
B.2.2 United States Federal Highway Administration (FHWA) test road.....	142
B.2.3 RN10 Trappes test road (France) .....	142
B.3 Test bridges used in Element 6 .....	144

B.4 Vehicles used in Elements 2, 3, 5 and 6.....	145
B.4.1 National Research Council of Canada (NRC) vehicle .....	145
B.4.2 Transport Research Laboratory of UK (TRL) vehicle .....	146
B.4.3 Hannover (Germany) test trailer .....	146
B.4.4 Australian test vehicles .....	147
B.5 The Laser RST Portable .....	148
ANNEX C GLOSSARY OF ABBREVIATIONS .....	149
ANNEX D LIST OF PARTICIPANTS.....	150

## EXECUTIVE SUMMARY

The road system is an enormous national asset representing on the order of one-half to three times Gross National Product. It facilitates commerce, communication, economic growth and social development. However, a significant portion of the road infrastructure in many countries is either ageing or reaching the end of its economic life. At the same time, infrastructure construction and maintenance funding is being reduced in relation to the increasing needs in most of these countries. These factors, along with the rapidly expanding demand for freight transport, require scientific and engineering responses to reduce pavement and bridge maintenance costs related to truck use and to develop better, more integrated design practices for vehicles, pavements and bridges. The DIVINE (Dynamic Interaction between Vehicles and Infrastructure Experiment) Project therefore set out to describe important aspects of the interaction between heavy vehicles and road infrastructure in an objective manner and to suggest ways in which those responsible for the principle elements of this interaction -- i.e. pavements, bridges, vehicles, transport policies and regulations -- could act to reduce the negative consequences of road freight transport and reduce overall infrastructure and user costs. The results of the project are presented in this Technical Research Report and in a separate report, *Dynamic Interaction between Vehicles and Infrastructure Experiment: Policy Implications* (pending).

### **A new working relationship requires a new approach**

Road freight vehicles operate in a highly competitive and strongly regulated environment and are essential elements in the enlarging global freight transport systems that support integrated logistics services. As well, the increasingly stringent operating parameters for heavy vehicles have brought about rapid technological improvements in vehicle design and operation. However, it is not always well understood that total freight vehicle operating costs, which are often distributed over several private companies, are many times larger than road maintenance costs. These vehicle operating costs are strongly influenced by road and traffic conditions and, in an indirect way, by regulations imposed by road agencies. Widely differing vehicle and infrastructure engineering disciplines, coupled with disparate public and private accountability, has led to a situation in which infrastructure and the heavy vehicles that use the infrastructure have never been considered as one system. In fact, the relationship has often contained negative elements, mainly reflecting the road-damage, safety, congestion and environmental concerns associated with heavy vehicles.

The situation is complicated because the demand for the transport of goods is increasing in both weight and volume terms. This trend, coupled with a need for greater responsiveness to customer needs, is leading to a demand for larger and heavier trucks with a larger diversity of configurations. The simple logic of more concentrated freight consignments leading to less freight vehicle travel and less truck exposure in road systems suggests that transport solutions that challenge current size and weight limits and the methods of applying such limits should be proposed.

It was not until the American Association of State Highway Officials (AASHO) Road Test in the 1950s that solid engineering information concerning the effects of axle loads on pavement performance

became available. There is now a need for a higher level of scientific knowledge about the interaction between trucks and pavements, and between trucks and bridges, in order to introduce regulations based on vehicle performance in terms of road-friendliness. A road-friendly vehicle is one whose operation in the road system will bring about less need for road maintenance for a given level of axle load.

The AASHO Road Test introduced the concept of pavement serviceability which led to increased attention being given to monitoring the functional condition of pavements and bridges for the sake of all road users. In spite of this, heavy vehicle users have not until recently received enough direct attention, especially if one recognises that uniformity of the pavement structure and evenness of the riding surface are needed for the road to be hospitable to the vehicle. In this regard, advanced road management techniques of the future should recognise the importance of the total outcome of the vehicle-road interaction in terms of costs to both road agencies and freight vehicle users. These techniques would encourage road-friendly vehicles carrying high weights on high-standard infrastructure rather than axle weight limits which are insensitive to vehicle or pavement qualities.

Over a period of 30 years, the OECD Road Transport and Intermodal Linkages Research Programme (RTR) -- formerly Road Transport Research Programme -- co-ordinated approximately 20 studies on the interaction between infrastructure and freight vehicles. The DIVINE Project built on all of these previous studies and represented an important milestone in the science, engineering and management of the vehicle-infrastructure system. It was a new approach that examined the use of improved heavy vehicle technology in conjunction with improved pavement construction and maintenance management techniques to potentially reduce pavement costs related to heavy vehicle use. In a similar vein, it also sought to reduce bridge construction costs through a better knowledge of the design traffic loads. One of the critical technical issues addressed in the DIVINE Project, therefore, was whether vehicle technologies which are pavement-friendly are also bridge-friendly.

### **DIVINE scientific results**

The DIVINE Project was an international co-operative research programme involving road agencies, road and bridge research organisations, and the private sector from 17 OECD Member countries. Major elements of the research were carried out in nine countries. The Project was overseen by the RTR Steering Committee with support from a restricted DIVINE Executive Committee responsible for the overall performance and co-ordination of the Project as well as financial and other matters. A Scientific Expert Group -- i.e. specialists in vehicles, pavements, bridges, road management and transport policy -- managed the project and acted as the focal point for the exchange of views, analysis of results, planning and execution of the research work and reporting. The scientific outputs of the DIVINE Project were subjected to external, independent peer review. The following sections summarise the significant scientific products of the DIVINE Project.

#### ***Dynamic loads affect pavements***

For relatively thick pavements (160 mm of bituminous material) horizontal strains measured at the bottom of the bituminous layer were found to be almost directly proportional to the dynamic wheel force. A 10 percent increase in dynamic wheel load, for example, produced a 7 - 12 percent increase in strain. Given the accepted relationship(s) between strain and pavement material damage, this implies significantly increased pavement wear under traffic which consistently applies such loads. In the case of thin pavements, horizontal strains are greater in magnitude than for thick pavements but are less sensitive

to dynamic wheel force and appear to be influenced by surface contact conditions between the tyre and pavement.

### ***Dynamic loading on highways shows some consistency***

Under mixed traffic, dynamic loads typically tend to concentrate at points along a road at intervals of 8 - 10 metres. On a smooth road, the cumulative sum of axle loads at a point of concentration is about 10 percent. On a rough road, this effect is at least twice as large. The concentration of dynamic loads for air suspensions has only about half the magnitude of that for steel suspensions. This phenomenon is heavily dependent on the road profile, the mix of suspensions on the vehicles in the traffic stream, the wheelbases of those vehicles and the range of their speeds. In circumstances where the composition of the truck traffic flow tends to be confined to a few particular types, the risk of pavement wear from spatial repeatability will thus be higher. Such circumstances are increasingly frequent, particularly as the nature of heavy goods vehicles tends to be function-specific.

### ***Dynamic loading depends on suspension type***

DIVINE confirmed that dynamic wheel forces depend on the suspension type, the profile of the road pavement and the speed of the vehicle. On reasonably smooth roads, for example, steel suspensions produce impact factors of 1.3 and air suspensions factors of 1.1 - 1.15 for the bogie axles of semi-trailers, while the difference was almost negligible for the single axles of rigid trucks or tractors. On rough roads, however, steel suspensions produce impact factors of 1.4 - 1.5 and air suspensions 1.2 for these bogies. These results imply that the “control” of longitudinal profile provides scope for reducing dynamic loading by heavy vehicles.

### ***Aspects of road wear are reduced with air suspensions***

The DIVINE accelerated dynamic pavement test showed that pavement profile deteriorates more rapidly under a steel suspension than under an air suspension carrying the same load. Some aspects of cracking and the maximum rut depth were also greater under steel suspension. Pavement wear under steel suspension was at least 15 percent faster than under air suspension. In the accelerated test, long-term pavement profile changes under steel suspension were correlated with both dynamic wheel load and local structural strength. On the other hand, very little long-term profile change occurred under air suspension.

### ***Vehicle dynamics can affect bridges***

The DIVINE bridge testing found that the surface profile of a bridge and its approaches are fundamental to the response of the truck suspension and in turn the dynamic response of the bridge. For a smooth profile, the influence of the truck suspension is insignificant, although the importance of the suspension increases as the unevenness of the profile increases. For medium-span to long-span bridges (20 - 70 metres) with smooth profiles, dynamic responses are relatively small for both air-suspended and steel-suspended vehicles. Within this range of responses, increased responses occur for air-suspended vehicles on 1.6 Hz (70 metre) bridges and for steel-suspended vehicles on 3.0 Hz (40 metre) bridges. For short-span bridges (10 metres) with poor profiles, large dynamic responses occur for both air-suspended and steel-suspended vehicles. The highest measured responses were for short-span bridges with low to

average damping traversed by air-suspended vehicles where axle hop was excited by short-wavelength roughness.

### ***Air suspensions can be road-friendly***

For pavements, DIVINE showed that in order to reduce pavement responses to heavy vehicles, it is necessary to control dynamic loading in both the low-frequency body modes and the high-frequency axle modes. With regard to controlling pavement wear, the DIVINE results showed that most profile changes were related to the low-frequency modes, with only a minor indication that the high-frequency modes produced profile changes. Similarly, DIVINE found evidence of rutting damage related to the low-frequency modes but was less conclusive on the specific influence of dynamic loading on cracking damage. In the important low-frequency modes, air suspensions generally have lower natural frequencies and can have higher damping than steel suspensions. These characteristics equate to significantly less dynamic loading by air suspensions provided that damping is maintained in service. Air suspensions do not necessarily have improved performance in the high-frequency axle modes and, again, require adequate damping.

For bridges, DIVINE showed that, in certain cases, there is a need to control the high-frequency axle modes with respect to the responses of short-span bridges. Air and steel suspensions alike can “tune” with bridge vibrations in specific parts of the spectrum of bridge frequencies, damping and profile conditions and vehicle speed. Under specific conditions for short-span bridges, air suspensions can produce large high-frequency responses.

### ***Suspensions need to be tested for road-friendliness***

The essential properties of road-friendly suspensions were confirmed to be low spring stiffness, very low Coulomb friction and a sufficient level of viscous damping. Such properties are generally to be found in well-designed and well-maintained air suspensions and it is unlikely that steel spring suspensions could achieve the desired level of performance. In addition, DIVINE showed that for axle group suspensions -- i.e. tandem and tridem axle arrangements -- the control of suspension equalisation performance is important.

The current European Commission (EC) requirement of 2 Hz maximum frequency and 20 percent minimum damping was found to generally succeed in differentiating between air and steel suspensions but is less appropriate to its original purpose of specifying performance equivalent to air suspension. It was found that the dynamic loading generated by suspensions is sensitive to both the frequency and damping of the suspension as measured in the EC bounce test. It was also found that the frequency and damping of air and steel suspensions are not independent parameters and that, for practical reasons, it is difficult to design an air or steel suspension with good damping and a frequency above 2 Hz.

The sensitivity of dynamic loading to suspension damping is such that there is very little increase in dynamic loading as the damping reduces from 20 to 15 percent, a slightly greater increase as damping is further reduced to 10 percent and then a strong increase as damping is reduced below 10 percent. This is particularly true if the suspension frequency is limited to 1.5 Hz. DIVINE also revealed that there is limited value in regard to reducing dynamic pavement loading by reducing suspension frequency below 1.5 Hz or in increasing damping beyond 20 percent. However, damping greater than 20 percent could have benefits for heavy vehicle safety performance and for reducing axle hop vibrations under severe conditions of road roughness.

The DIVINE project suggests a suspension test method that may be more accurate and consistent than the EC bounce test. However, DIVINE experimentation led to the recommendation that a “road-friendly” suspension should be defined by using the EC bounce test and the following criteria:

- frequency of 1.5 Hz or less; and
- damping of 20 percent or more.

### ***New considerations in pavement engineering***

DIVINE has shown that pavement response to vehicle dynamic loading is sufficiently high to warrant specific consideration in pavement design methods, but that the attention required may differ depending on the thickness of the pavement being considered. In this regard, more research is needed on the response of thin pavements as well as on tyre contact effects. The structural variability of pavements also needs to be considered in standards for new construction and in pavement serviceability measurements.

The DIVINE results indicate that profiles need to be monitored and controlled in order to reduce the degree of dynamic loading. The International Roughness Index (IRI) may provide some assistance in this regard, but better algorithms and more appropriate indices may be needed. There is also a need to monitor and control longitudinal road profiles in order to determine their effect on spatial repeatability and to assist in the development of an algorithm to establish limiting profiles for repeatability.

It was never the intention of DIVINE to validate pavement performance models or develop new models. However, DIVINE showed that structural strength and dynamic force interact. This result makes it appear to be essential that pavement structural variability and dynamic loading should both be included in performance models in the future.

### ***New insights into bridge responses***

The DIVINE research showed that the dynamic response of bridges can only be understood when it is considered as part of a system which incorporates the bridge, the road profile, the vehicle mass, configuration and speed as well as the vehicle suspension. The need to understand this complex system is becoming increasingly important in an era when an ageing and deteriorating bridge infrastructure is being asked to carry ever increasing loads as industry and governments seek improvements in transport efficiency. The DIVINE project gathered unique data which suggest ways of providing improved guidance for those involved in each aspect of the bridge industry -- design, maintenance, evaluation and management. Likewise, the DIVINE research results provide suggestions for encouraging the development of more “bridge-friendly” suspension systems.

### ***Road cost allocation is an interactive issue***

The DIVINE results provide no direct information on road cost allocation but indicate that current pavement design and strategic evaluation procedures may over-estimate the effect of wheel loads relative to the effects of pavement construction variability. Given the important role of cost recovery in road funding and the significant allocation of road costs to truck weight and truck travel, extensive research is needed to better understand the relative contributions to road wear of truck weight, vehicle

road-friendliness, road initial and current condition and environmental effects. From this standpoint, the DIVINE results should greatly assist OECD Member countries in designing effective research programmes.

## **Conclusion**

The DIVINE Project represented a new approach to the funding, conduct and reporting of international research in the road sector. It has resulted in significant advances in the scientific understanding of the interaction of vehicles, pavements and bridges as well as clearly defining a new concept of road-friendly vehicle suspensions. The scientific and technical results described in this report will lead to improved design, construction, maintenance and management practices for bridges, pavements and vehicles. The results therefore have tremendous implications for planners, engineers, researchers and a range of private sector interests in the road transport sector. In addition, the policy implications of the DIVINE project -- presented in a separate report -- are far-reaching in their potential economic impacts by promoting a new way of thinking in regard to the various restrictions on heavy vehicle operations in OECD Member countries. From this standpoint, the DIVINE Project has proven to be a groundbreaking effort that is ushering in a new era in the road transport sector.

## CHAPTER I. INTRODUCTION

### I.1 Purpose of the Project

The DIVINE (Dynamic Interaction between Vehicles and Infrastructure Experiment) Project was a scientifically planned series of investigations, analyses and tests carried out, co-ordinated and interpreted by an OECD Scientific Expert Group with the collaboration of institutes and companies from participating Member countries.

The Project built on the work of a number of previous Expert Groups which investigated various aspects of infrastructure planning, construction, preservation and regulation. In particular, an Expert Group on the Dynamic Loading of Pavements (OECD Road Transport Research Programme, 1992) identified significant opportunities for improving understanding of the interaction between heavy vehicles, pavements and bridges and the benefits of modern “road-friendly” vehicle suspension technology.

The main purpose of the DIVINE Project was to provide scientific evidence of the dynamic effects of heavy vehicles and their suspension systems on pavements and bridges, to support transport policy decisions that affect infrastructure and road freight transport costs and to indicate the most productive avenues for improving the interaction of heavy vehicles with roads and bridges. The research work was planned so that the Group’s findings would have significance for all Member countries, even though infrastructure and vehicle conditions may vary from country to country and from region to region. Recent technological advances in vehicle design and in infrastructure management were factored into the research plan and six separate lines of investigation (termed Research Elements) were established. Attention was also given to the need to enhance heavy vehicle safety and to reduce environmental effects.

This report presents the findings and technical implications of the work. It is supported by a series of research reports published under the auspices of the participating institutes. It is recognised that, due to the widely differing engineering disciplines involved and to the disparate public and private accountabilities of the two “partners” involved, the infrastructure and the heavy vehicles which use it have never been considered as one transport system. In fact, the relationship has often been difficult with negative connotations, mainly reflecting the road-damaging, safety, congestion and environmental influences of heavy vehicles. Attempts are made in the report to describe important aspects of the interaction between heavy vehicles and the infrastructure in an objective manner and to suggest ways in which those responsible for pavements, bridges, vehicles, transport policies and regulations, and research could act to reduce the negative consequences of road freight transport, reduce costs and improve efficiency.

### I.2 The interaction between freight vehicles and infrastructure: socio-economic factors

The funds available for road infrastructure construction and maintenance are declining in relation to the increasing financial requirements of the extensive road networks around the world. At the same time, rapidly expanding freight transport services are placing severe and increasing demands on this

same infrastructure. These pressures on the road infrastructure will continue to exist even if the use of other transport modes and multimodal transport opportunities are fully exploited.

Nations are adopting sustainable mobility policies and there is increasing concern about traffic congestion, including the role of trucks in producing such congestion, the effects of road vehicle gaseous and noise emissions on the environment and the effects of heavy vehicles on highway safety. While the technological support of Intelligent Transport Systems (ITS) is seen as one potential means for alleviating long-term pressures on freight transport systems, continued economic growth, employment and quality of life will require reforms in the physical as well as logistical aspects of freight transport systems.

Demands for the transport of more goods, by both weight and volume, and for greater responsiveness to customer needs, will result in the consideration of larger and heavier trucks, as well as increased efficiency and diversity of truck configurations. Significant improvements in highway safety are also being called for, and the role of heavy vehicles in road hazards and congestion is coming under increasing scrutiny. The simple logic of more concentrated freight consignments -- either by weight or volume -- leading to less freight vehicle travel and less truck exposure in road systems will increasingly call for transport solutions that require reliable answers to truck-road interaction questions.

While national and regional vehicle size and weight regulations have been in force in some form for more than 50 years, it was not until the 1950s, and the AASHO Road Test (Highway Research Board 1962), that solid engineering information concerning the effects of axle loads on pavement performance became available. Since the 1970s, an increasing amount of research focusing on the interaction between trucks and roads has been carried out including accelerated pavement testing and full-scale, long-term field trials. This research has led to significant advances in measurement techniques and computer modelling. The OECD has played a leading role in fostering and co-ordinating this research. Over a period of 30 years, the OECD has co-ordinated some 20 studies on the interaction between the infrastructure and freight vehicles. The DIVINE Project represents an important milestone in the science, engineering and management of the vehicle-infrastructure system.

### **I.3 Organisation and management of the DIVINE Project**

#### ***I.3.1 Scientific approach developed by the OECD***

The infrastructure research projects carried out in recent years under the OECD Road Transport and Intermodal Linkages Research Programme (RTR) -- formerly Road Transport Research Programme -- have addressed scientific and economic questions concerning the effects of heavy vehicles on infrastructure, including pavement construction and maintenance requirements. The DIVINE Project focused on gaining a more comprehensive understanding of the implications of road freight vehicle operations for three key interacting elements: pavements, bridges and vehicles. It examined the possible role of new vehicle suspension technologies in reducing the damaging effects of heavy vehicles on pavements and bridges and for permitting maximum efficiencies for road freight transport.

A key element of the DIVINE research was to quantify the potential benefits of the wider use of heavy vehicles equipped with so-called "road-friendly" suspensions. In the context of the present report, road-friendly means a heavy goods vehicle, the design of which minimises the dynamic loading applied to road pavements and bridges. Although it is recognised that tyre characteristics can have a significant effect on pavement wear (see Annex A for definition), they do not necessarily have a significant effect on dynamic loading. Therefore, special focus is placed on the design features of the suspension type.

### ***I.3.2 Organisational structure of the Project***

The DIVINE Project was an international co-operative research programme with a well-defined research plan, a management structure and a budget administered by the OECD. It involved road agencies and road and bridge research organisations, as well as the private sector, with active participation from 17 OECD Member countries. Major elements of the research were carried out in nine countries.

The Project was overseen by the RTR Steering Committee, the most senior committee in the RTR Programme. This committee was supported by a restricted Executive Committee responsible for the overall performance and co-ordination of the Project as well as financial and other matters. The Executive Committee also considered the strategic issues surrounding the project, and planned the implementation of its results. A Scientific Expert Group managed the project at the scientific level and acted as focal point for the exchange of views, analysis of results, planning and execution of the research work and reporting. In order to ensure appropriate co-ordination between the different Elements of the Project, a Programme Manager was appointed. Reporting of the work carried out in the Scientific Expert Group and in each of the Elements was a key part of the management of the Project (see Figure I.1).

The DIVINE research programme was the result of syntheses of national research programmes, national road freight policy options and the need for vehicle performance standards. The programme was broad and diverse in scope and relied on a clear identification of research plans, standardisation of research techniques and co-ordination involving the OECD, representatives of Member countries and the DIVINE Programme Manager. The Expert Group included specialists in vehicles, pavements, bridges, road management and transport policy.

This working method facilitated technology transfer from one sector to another and frequently from one country to another, and many less tangible benefits accrued. These included the widening of technical contacts, the cross-fertilisation of ideas and a wider appreciation of the entire range of problems experienced by similar groups of workers in different technical and economic environments.

The project commenced in 1993 and interim results were presented at a seminar held in Sydney, Australia, in 1995 (OECD and Austroads, 1995). The final results of the research were widely disseminated in 1997 through conferences in the North American, European and Asia-Pacific regions. These conferences were designed to engage road and vehicle practitioners and to debate and advance the most important policy issues related to the findings of the DIVINE Project in all regions.

### ***I.3.3 Funding of the DIVINE Project***

Participants in the Project incurred considerable costs in carrying out the required experimental, analytical and reporting work. The total cost of the Project was of the order of US\$1.3 million. In addition, many of the active participants bore a substantial proportion of their own costs by providing, for example, equipment and personnel at no cost to the Project, by supporting the work of other Elements at no cost, or by other means.

**Figure I.1. Management and structure of the DIVINE research programme**

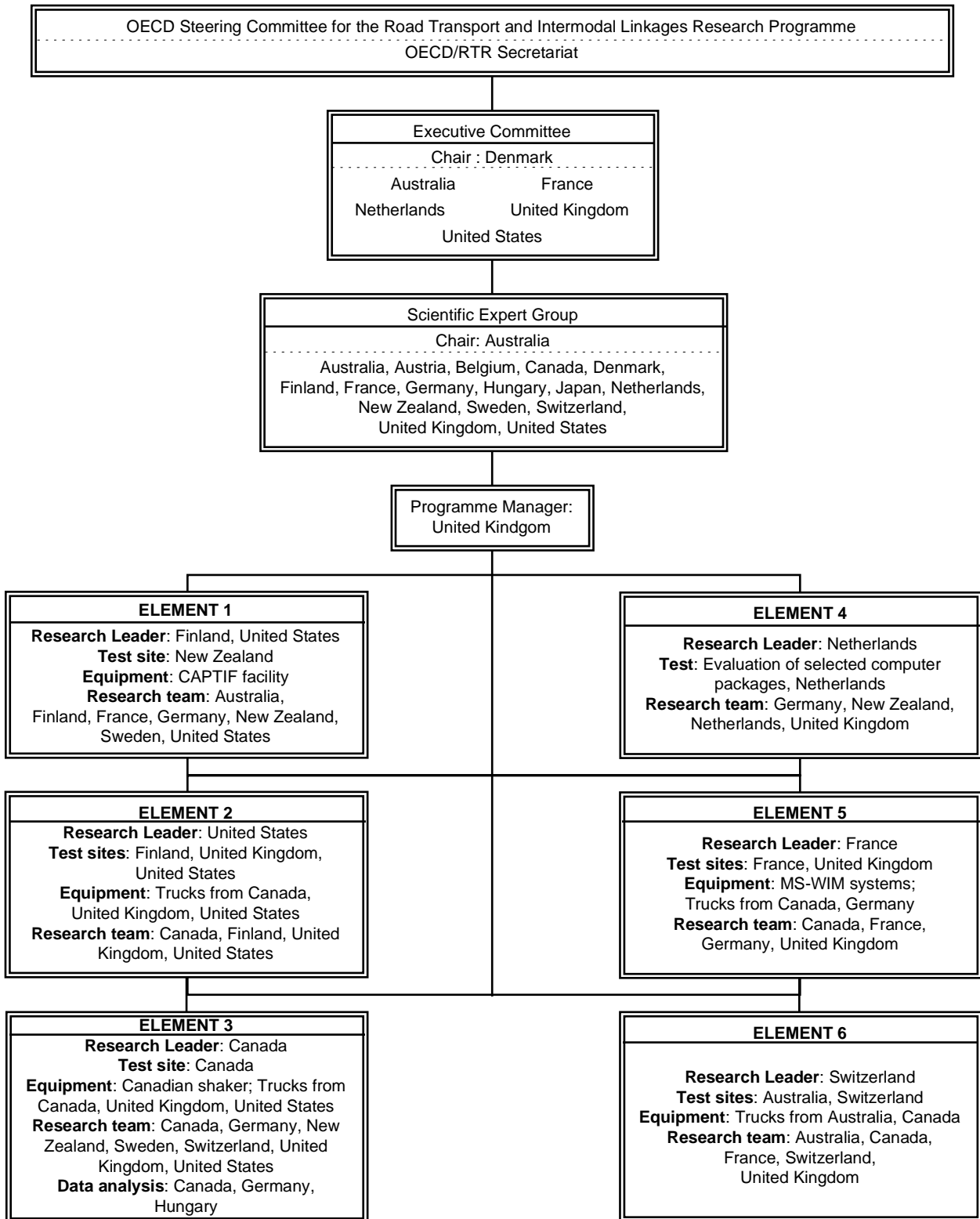

Indirect contributors also provided substantial resources to the Project in the form of grants, free use of equipment, software or other resources, and these amounted to a further substantial sum. Such “in-kind” resources were made available by research institutes, government and industry. In total, the estimated cost of the DIVINE project, including the core budget of US\$1.3 million, was about US\$3.4 million.

The core budget, to cover direct cash expenditure, was met from a fund raised initially by the RTR Steering Committee, whose members contributed cash sums to the fund in two portions through the life of the Project. In total, 17 countries made donations to the fund, as well as the European Commission (DG VII). Further details of the budget for the DIVINE Project are given in Table I.1 which shows the financial support received and the source and estimated amounts of in-kind contributions. The funds were administered by the OECD, with a systematic expenditure approval procedure that involved the Programme Manager.

#### ***1.3.4 Review procedures***

The scientific outputs of the DIVINE Project -- i.e. the scientific reports for each of the Research Elements -- were externally reviewed before publication. The purpose of the independent peer review was to provide the authors of the research reports with an assessment that would enable them to complement, amend or provide further analysis, as deemed necessary, in order to produce a high-quality report. To this end, a panel of reviewers, each an expert in a field covered by DIVINE, was selected by the DIVINE Executive Committee. Reviewers were provided with the Terms of Reference and asked to focus on the scientific and engineering rigour of the research, its analysis and the validity of the conclusions drawn.

### **1.4 Brief details of the DIVINE Project**

#### ***1.4.1 Objectives of the Project***

The DIVINE Project represented an internationally co-ordinated research effort to advance understanding of the scientific relationship between different vehicle suspension systems and pavement wear, and its implications for asset management and productivity in road freight transport. It addressed key issues being faced today and those that are likely to become increasingly important in the future. The most prominent of these issues are:

- reducing all types of truck impacts on road networks, including deterioration in road condition, negative safety and environmental effects;
- improving road freight productivity through reforms in vehicle size and weight policy;
- quantifying the potential benefits of “road-friendly” vehicle suspensions in extending pavement life and reducing pavement maintenance costs; and
- taking greater account of the effects of heavy vehicles in pavement and bridge design methods adopted in the construction of new infrastructure.

**Table I.1a. National funds directly paid to the DIVINE Project**

Country (funding partner)	Grant amount in US\$ (or equivalent rounded figures)
<b>Australia</b> (Consortium: government & private sector)	82 000
<b>Austria</b> (Government)	50 000
<b>Canada</b> (Consortium: government & private sector)	74 000
<b>Denmark</b> (Government)	43 500
<b>Finland</b> (Government)	50 000
<b>France</b> (Government & private sector)	125 462
<b>Hungary</b> (Government)	15 000
<b>Iceland</b> (Government)	15 000
<b>Japan</b> (Government)	150 000
<b>Netherlands</b> (Government)	62 500
<b>Norway</b> (Government)	51 500
<b>Sweden</b> (Government & private sector)	66 000
<b>United Kingdom</b> (Government)	81 500
<b>United States</b> (Government)	200 000
Total national contributions	1 066 462
EU (DG VII)	222 000
<b>GRAND TOTAL</b>	<b>1 288 462</b>

**Table I.1b. In-kind contributions to Research Elements**

National in-kind contributions	Industry in-kind contributions	Amount in US\$ (rounded figures)
Australian Gov.		421 000
	Boral, BPW, York (Australia) (R.EI 6)	76 500
Canada Gov.(NRC) (R.EI 3)		310 000
Finland Gov. (Finnra) (R.EI 2)		50 000
France Gov. (LCPC) (R.EI 5)		240 400
	Renault Vehicules Industriels (France) (R.EI 5)	27 400
	Cofiroute (France) (R.EI 5)	7 300
	Transfibre (France) (R.EI 5)	840
	Drouard (France) (R.EI 5)	11 000
	Vectra/Leem (France) (R.EI 5)	10 000
	TNO (Netherlands) (R.EI.4)	40 200
	TNZ (New Zealand) (R.EI.1)	111 500
Switzerland Gov. (FOH)		237 700
UK Gov.		137 000
US Gov. (FHWA)		263 250
<b>Domestic funding to Research Elements</b>		
Germany (R.EI 3)		55 000
Switzerland (R.EI 6)		105 000
<b>International funding to Research Elements</b>		
United Kingdom (R.EI 2) to VTT		27 400
<b>Total in-kind contributions</b>		<b>2 131 490</b>

Source: OECD

Due to varying transport policy environments in OECD Member countries and between regions, the implementation of the DIVINE results will vary significantly. While all countries are vitally concerned with the productivity of heavy freight vehicles and their effects on infrastructure wear, safety, traffic congestion and pollution, different priorities apply in different regions within the OECD. Europe, for example, is generally concerned with issues of traffic congestion and the environment, North America is very much concerned with bridge and highway safety, and productivity improvements are on the agenda in the Asia/Pacific region.

It was considered important, therefore, that the DIVINE Project provide results which would be highly relevant to these policy and regionally specific issues. At the same time, the participants in the Project did not wish to be wholly responsible for indicating how the scientific recommendations should be applied to policy issues. Accordingly, the DIVINE Project was designed to provide a scientific basis for:

- quantifying the influence of heavy vehicle suspensions on pavement life and/or costs;
- maintaining road-friendly vehicle performance in service;
- quantifying the influence of heavy vehicle suspensions on bridge life and/or costs; and
- proposing road condition indices which are most relevant to the deleterious effects of trucks.

#### ***1.4.2 DIVINE research aims***

The main purpose of the research was to improve vehicle manufacturing, pavement construction and maintenance and bridge design. The research aimed to contribute to:

- the encouragement of the design and use of road-friendly vehicles and procedures for the design and assessment of the road-friendliness of these vehicles;
- an evaluation of the consequences for bridge design of the introduction of new vehicle body suspension technologies;
- a reduction in the deterioration of road networks (including pavements and bridges);
- an evaluation of policy options pertaining to axle weights, axle configurations and the number of axles;
- the development of allocation procedures for road costs and maintenance planning related to truck weight; and
- a common international basis for future joint standards, testing procedures and policy initiatives for heavy freight vehicles.

The programme consisted of six inter-related elements of research which together formed a package that attempted to answer four basic questions:

1. Under controlled conditions, by how much do dynamic loads reduce the life of pavements, and what influence do they have on bridge performance?

2. How do the results obtained under controlled conditions transfer to real road conditions with mixed traffic and different environmental conditions?
3. How should we specify and test heavy vehicles for road-friendliness?
4. How much increase in pavement life should we expect from the use of road-friendly heavy vehicles in practice?

The research programme was designed to find parallel answers to each question by using different approaches and data sets in order to increase confidence in the results and to allow for complementarity of some of the answers in the event that one of the Elements failed to deliver results.

## **I.5 Presentation of results**

The results of the DIVINE research are presented in this report in a manner which aims to promote the implementation of the findings of the project as well as to provide information on essential aspects of the research work undertaken, data analysis, scientific results and conclusions. In structuring this report, greatest consideration was given to: (i) how the results could be used in practice, and (ii) how the DIVINE Project has advanced scientific knowledge.

### ***I.5.1 Practical findings for implementation***

The Expert Group predicted that the main applications of the results of the DIVINE research are likely to be:

- improved methods for evaluating the consequences of truck regulatory policy changes;
- improved means of integrating the infrastructure and freight vehicles in transport policy decisions;
- technological advances in pavement, bridge and vehicle engineering;
- improved understanding of bridge limitations and costs, in relation to their use by heavy vehicles; and
- technological advances in testing techniques and computer modelling.

### ***I.5.2 Findings for advancing scientific knowledge***

The DIVINE Project represents a major step in increasing scientific knowledge of truck-road interaction and is part of a lineage which includes the AASHO Road Test, the advent of accelerated pavement testing and rapid advances in measurement, monitoring and modelling techniques. While all of these developments have contributed to the knowledge of vehicle influences on the infrastructure, they have concentrated on one element of the system -- usually the pavement -- and have not truly considered the effects of all elements in an interactive way. In this respect, the DIVINE Project is a landmark scientific study.

It is therefore important to explain the scientific significance of the DIVINE Project in the context of other major advances in knowledge and to fully document DIVINE's research elements. The consequent emphasis on the interactive aspect of DIVINE is somewhat at odds with imperatives for the application of the research findings which require identification of information relevant to each element of the system: pavements, bridges and vehicles. This was resolved in the Report structure by presenting the scientific findings in an interactive sense in Chapter IV and then presenting the implications for each element of the system in Chapter V.

### ***1.5.3 Structure of the Final Technical Report***

In order to provide outputs which assist both the application of the research findings and fully describe the scientific significance of the work, this report is supported by a collection of scientific reports on the various research elements carried out under DIVINE.

The Report is structured as follows:

- **Chapter II: *Origins of the DIVINE Project.*** The economic and regulatory issues surrounding the work and its scientific background are presented. The results of a survey of key policy issues carried out by the Expert Group are outlined and the scientific basis of the project is discussed with reference to the state-of-the-art review of dynamic loading of pavement conducted by an OECD Expert Group in 1992 (OECD Road Transport Research Programme, 1992).
- **Chapter III: *The infrastructure-vehicle system: A new approach.*** To assist non-specialists, the main components and characteristics of the vehicle-infrastructure system are described. Conceptual models forming the basis of the new approach to vehicle-infrastructure interactions are presented and the DIVINE Research Programme and Elements are summarised.
- **Chapter IV: *Performance of the vehicle-infrastructure system: Findings of the DIVINE Project.*** The results of the project are described with respect to the dynamic interaction between the infrastructure and heavy vehicles. They are presented by describing the results for the following sets of influences:
  - vehicle effects on the dynamic responses of pavements and bridges;
  - effects of heavy vehicle suspensions on pavement wear; and
  - methods for assessing vehicle road-friendliness.
- **Chapter V: *Improving the vehicle-infrastructure system: Implications of the DIVINE research.*** Without providing answers in all areas, the DIVINE Project has wide implications for the more rational analysis of infrastructure use by heavy vehicles. The potential role of technological advancements in pavements, bridges and vehicles is considered, and the needs for further research are discussed. The conclusions and recommendations are summarised.
- **Annex A** provides the reader with some definitions of terms used in the report, together with an overview of the development in pavement and bridge design practices and pavement analysis procedures that take account of dynamic loading.

- *Annex B* briefly describes the facilities and equipment used in the various DIVINE research programme Elements.
- *Annex C* provides a glossary of abbreviations.

## **I.6 Significance of the DIVINE Project**

The DIVINE Project has investigated the value of a key aspect of road-friendly vehicle technology and it is hoped that its results will provide a new inter-disciplinary framework for assessing the interaction between vehicles and the infrastructure. Successful elements of the Project included a strong focus on highly relevant policy issues, strong support from national governments and the European Commission and the involvement of private industry.

It is anticipated that the DIVINE results will accelerate the ongoing change in current perceptions of the interaction between trucks and roads. The view that all trucks “damage” roads will need to be reviewed in the light of the results of the DIVINE Project which indicate that trucks “wear” pavements at a rate which is dependent not only on the static load carried by the vehicle, but also on the dynamic performance of the vehicle, on the longitudinal profile of the road and on the structural variability of the pavement.

DIVINE has shown that it is no longer appropriate to isolate the vehicle effect: even though the truck imposes the “load” on the infrastructure, the research has shown that uneven roads and non-uniform construction increase the road wear and structural distress, as well as the fatigue of bridges, caused by heavy vehicles. The DIVINE Project could provide the catalyst for an improved partnership between those responsible for the infrastructure and the road transport industry.

The DIVINE Project has also provided an historic opportunity for further inter-disciplinary research co-operation. Significant economic benefits are known to be available from improved interaction between road freight vehicles and the infrastructure, and some essential characteristics of vehicle road-friendliness have been established. Deficiencies in the current knowledge of pavement and bridge performance under dynamic loading now need to be addressed in order that costs to infrastructure providers and users may be reduced in the future.

The DIVINE Project has provided a much-needed framework whereby current knowledge of pavement performance related to vehicle axle loads may be expanded on an international, co-operative and scientifically managed basis.

## BIBLIOGRAPHY

HIGHWAY RESEARCH BOARD (1962), *The AASHO Road Test. Report 7: Summary Report* National Academy of Sciences - National Research Council Publication 1061, Washington DC.

OECD AND AUSTRROADS (1995), *Dynamic Loading of Heavy Vehicles and Road Wear Mid-term Seminar*, Proceedings, Sydney.

OECD ROAD TRANSPORT RESEARCH PROGRAMME (1992), *Dynamic loading of pavements*, OECD, Paris.

## CHAPTER II. THE ORIGINS OF THE DIVINE PROJECT

### II.1 Economic and regulatory issues

#### II.1.1 *Background*

Efforts are being made in many countries, at many levels, to reduce the total costs of road transport to society, to improve highway safety and to reduce the environmental impacts related to roads and vehicles. It has been increasingly recognised in recent years that heavy vehicles require specific consideration and, to this end, measures have been sought to control their effects on pavement and bridge wear, traffic accidents, traffic congestion, use of road space, compatibility with geometric design, traffic control devices, air quality and traffic noise levels.

At the same time, increasingly sophisticated means of designing, monitoring, maintaining and managing pavements have been developed, supported by the availability of improved data on heavy vehicle traffic and axle loads generated by increased use of weigh-in-motion (WIM) systems. The adoption of mechanistic procedures for the design of pavements, and the increasing use of Pavement Management Systems (PMS), have resulted in a strong focus being placed on pavement response to load, design life, maintenance intervention strategies and the strong influence of heavy vehicle loadings on the initial calculated life and remaining life of pavements. Similarly, bridge design methods are highly dependent on heavy vehicle loads. Size and weight limits in all countries contain important requirements for controlling the gross weight of heavy vehicles and the manner in which this load is distributed over the vehicle's axles. However, these activities are based on very simple models of vehicles, pavements and bridges, and do not provide adequately for the interactive nature of the infrastructure-vehicle system.

The DIVINE Project was designed to provide scientific tools to assist in dealing with the problems of traffic growth and pavement deterioration and to take advantage of vehicle innovations, including improved suspension configurations, to enhance productivity. Such innovations also have the potential to enhance safety and reduce environmental impacts.

The DIVINE Project was dedicated to the concept of identifying technical means for reducing road costs at the same time as providing the potential for improving the productivity of road freight operations. The potential for productivity improvement depends on a review of truck size and weight limits and related regulatory policies. One important scenario which needed to be addressed by the DIVINE Project was the introduction of legislation for the road-friendliness of vehicles; for example, current European Community (EC) directives provide an example of road-friendliness standards which could be more widely adopted.

### **II.1.2 Reducing road costs**

As already discussed, a significant portion of pavement construction and maintenance costs is attributed to the effects of heavy vehicle traffic, which in turn is related to axle load. The method of attribution usually involves a “power law” relationship which means that initial construction standards and the attributable wear or damage -- and hence the costs -- increase at a faster rate than the axle loads.

The proportion of total road costs directly attributable to heavy vehicles varies across countries, but is always significant (for example, up to 50 per cent of pavement rehabilitation costs). The remainder of road costs is considered to be related to the provision of mobility and road space for other vehicle classes as well as to other factors — such as environmental conditions — which are not directly related to levels of road use.

A recent OECD study (OECD Road Transport Research, 1994) found that total annual road funding ranges between US\$10 and 90 million per 1 000 km of road length, that total funding represents 0.2 - 1.9 per cent of GNP in Member countries and that the distribution of these funds between new construction, rehabilitation and various classes of maintenance varies significantly across countries. However, rehabilitation and maintenance costs generally represent between 40 per cent and 80 per cent of total road costs. As a guide, road maintenance costs (including rehabilitation costs) could typically represent 0.4 per cent of GNP, or an annual unit cost of US\$ 15 million per 1 000 kilometres of road length.

Road managers in all countries face the dilemma of balancing the demand of increasing truck traffic brought about by economic growth -- generating increased road construction and maintenance costs -- and the increasing consumer expectations for improved road condition and traffic safety and reduced road budgets (OECD Road Transport Research, 1994). At the same time, the road system is an enormous national asset, facilitating commerce, communication, economic growth and social development. Although the road infrastructure in many countries is ageing, with significant proportions of road infrastructure reaching the end of its economic life, the asset value is of the order of one-half to three times GNP. It is therefore understandable that there is a strong element of road protection in national and local regulatory policies.

In order to provide new options for solving these problems, the DIVINE Project set out to quantify -- for the first time -- the influence of heavy vehicle suspension design, pavement longitudinal profile and pavement structural variability on pavement wear and pavement damage. The use of improved heavy vehicle technology, pavement construction practices and maintenance management techniques has significant potential for reducing pavement costs related to heavy vehicle use. Bridge construction costs could potentially be reduced as a result of a better knowledge of the true impact of design traffic loads. One of the critical technical issues addressed in the DIVINE Project, therefore, was whether vehicle technologies which are pavement-friendly are also bridge-friendly.

### **II.1.3 Reducing user costs**

Despite the very substantial value of the road asset and the significant portion of nations' budgets devoted to its construction and upkeep, the costs borne by road users are typically ten times those borne by road providers (OECD Road Transport Research, 1994). This ratio is highly-dependent on the commitment of both sufficient maintenance funds and the volume of traffic using the road. The report on *Road Maintenance and Rehabilitation: Funding and Allocation Strategies* (OECD Road Transport

Research, 1994) included *inter alia*, the following “commandments” to governments and road administrations:

- “Road and bridge maintenance should be pursued for the sake of users. Therefore, public participation is an essential part of developing the road maintenance programme.
- User costs must be treated as important costs and included in the analytical framework of Road and Bridge Management Systems.”

Road transport costs represent an extremely important component of a nation’s economy, typically 2 - 17 per cent of GDP (OECD, 1994). Advanced industrialised economies fall in the lower range of these costs. These costs accrue to both commercial users -- such as freight vehicle operators -- as well as private users and are reflected in the prices of goods and services provided to the consumer.

All user costs, including both light vehicle and heavy vehicle costs, increase as roads deteriorate. Although the impact of road condition on light vehicle costs is very significant, by virtue of their much greater numbers, they are not considered in this report.

The following two types of user costs are significant for freight vehicle operations:

- As roads deteriorate to a significant degree, road users experience a reduction in ride comfort, and hence speed, and an increase in vehicle maintenance costs, fuel consumption and freight damage costs. These might be termed direct user costs.
- Size and weight regulations constrain payloads and therefore tend to increase the truck travel required to perform a given freight task, compared to the truck travel which might occur under higher limits. Truck travel in turn is directly related to vehicle operating costs which tend to be dominated by the cost of fuel and driver wages. These might be termed indirect user costs.

#### *Direct user costs*

Costs increase as the unevenness, or roughness, of the road surface increases. However, the largest components of heavy vehicle maintenance costs relate to the engine, drive-line and tyres, and only part of the tyre cost can be attributed to road unevenness. Another relatively large cost to heavy vehicle operators relates to the structural wear of the vehicle chassis and body. Operators face three options in response to this, each of which involves a cost: repair or replace parts more frequently, replace the whole body or vehicle more frequently, or specify a stronger vehicle with increased tare weight to cope with rougher operating conditions (the latter option is also addressed below under indirect user costs). Other maintenance cost components which could be related to road evenness, such as suspensions, are relatively minor for trucks.

Fuel costs will also increase with increasing road unevenness. However, in the short term, the speed reductions associated with rougher roads would tend to counteract this effect. Reductions in speeds resulting from increasing unevenness would tend to be more cost-sensitive because of the resulting increased travel time, increased vehicle operating costs and, ultimately, reduced productivity. There is some evidence, however, that in the longer term, drivers become accustomed to driving on higher levels of road unevenness, which results in a relatively little impact on driving speeds and trip times.

Deteriorating ride quality resulting from an increase in unevenness has implications for increased driver fatigue and for reduced road safety. It also has the potential to reduce productivity and increase cargo damage, although the latter would mainly apply to sensitive commodities such as electronic equipment or hazardous materials.

To summarise, with respect to direct user costs for freight vehicles, it would appear that structural wear of the vehicle chassis and body, roughness-induced speed reductions and tyre wear are likely to be the most significant influences.

#### *Indirect user costs*

Improvements in the productivity of freight vehicles can potentially result in significant reductions in vehicle operating costs. This represented an important policy-oriented issue with regard to the DIVINE Project. Another form of indirect user cost related to road condition may arise from cost penalties involved when increased vehicle tare weight is required in order to ensure adequate durability for operation on roads in poor condition.

Transport productivity and efficiency improvements are essential to the international competitiveness of industries. Increased axle load limits result in greater productivity for truck operations and hence lower costs. To a large extent, these savings are passed on to the users of transport services and also result in lower costs of goods to consumers. However, any increased costs in the construction and maintenance of a nation's highways are an important limitation on the extent to which economic benefits may be achieved in practice.

Again, freight vehicle operating costs far exceed road costs attributable to those vehicles and relatively large savings in transport costs are achievable by targeting productivity improvements. By way of example, in the Australian context (1989/90), the average annual operating cost of a six-axle vehicle was US\$175 000, compared to the average annual road track costs attributable to the same vehicle of US\$11 300 (Interstate Commission, 1989)

The implementation of productivity improvements clearly depends on national policies with respect to road funding, road user charges, size-and-weight limits and vehicle regulations. The DIVINE Project recognised three types of policy outcome:

- reduce pavement wear (and hence reduce maintenance costs);
- improve productivity while avoiding increases in road costs; and
- reduce road costs *and* increase productivity.

The DIVINE Project strongly oriented its work towards the latter objective.

Increased payloads and productivity can be brought about by a mix of transport policy options selected to best suit the regulatory and economic environment in each country. Components of these policy options could include the following:

- The possibility of increasing gross weights for road-friendly vehicles, perhaps by adding axles rather than increasing individual axle weights. This may involve an increased use of tridem groups in place of tandem groups.

- Considering an increase in axle group weights on proven road-friendly tandem and tridem groups.
- Implementing a sound means for measuring and assessing the road-friendliness of heavy vehicle suspensions (including the dynamic and load-sharing performance of suspensions).

#### ***II.1.4 Legislation for road-friendly vehicles***

Recent trends in vehicle technology, especially the increasing use of air suspensions in place of steel suspensions, have led to consideration of the merits of legislating for the road-friendliness of heavy vehicles using type-approval requirements. The EC directives applicable to single driven axles eligible for increased harmonised weight limits require the use of air suspensions, or equivalent, and dual tyres. The EC requirements include a performance-related standard for non-air suspensions that involves a simple dynamic test which includes the frequency and damping of the suspension. As this standard does not directly measure suspension dynamic loading performance, but specifies certain suspension dynamic characteristics, it could be termed a parametric standard.

There was some concern in the vehicle industry that the EC suspension requirements were over-simplified, and any moves to widen the application of such requirements appeared to warrant further research into both the method of assessment of suspensions and the standard of performance required.

#### ***II.1.5 Survey of key technical issues in policy formulation***

In order to establish the relevance of the DIVINE results to different areas of scientific research and policy making, the Scientific Expert Group carried out a survey of the most important policy issues with regard to the interaction between infrastructure and heavy vehicles. Members of the Group contacted the principal policy formulators on truck size and weight issues, as well as pavement and bridge design and maintenance, in their respective countries. From the responses to the questions put to these individuals or institutions, the main issues identified were as follows:

##### *Pavement design and maintenance for use by trucks*

- Should pavement design take account of the effect of dynamic loads on pavement life?
- What pavement performance models are most appropriate for new and rehabilitated pavements?
- What increase in pavement life should be expected if road-friendly vehicles are used in practice?
- What is the optimum type of road maintenance and timing?
- Do we really know how pavement damage is initiated and how it propagates?

*Vehicle road-friendliness*

- There is a need for an improved method of assessing vehicle road-friendliness and for international harmonisation of road-friendliness assessment.
- There is a need for vehicle owners to maintain road-friendly vehicle performance in service and to ensure the means to do so.

*Truck regulations*

- What is the effect of single and multiple (tandem, tridem and quadruple) axles on pavement performance and what are the limiting regulations for each for equivalent pavement damage?
- In the implementation of regulations for road-friendly vehicles, there is a need to minimise the uncertainty regarding the acquisition of new equipment by the transport industry.

*Longitudinal road profiles*

- What is the relevance of current road condition indices to truck effects?

*Pavement economic assessment*

- There is a need to quantify the effect of different suspensions on road costs.
- There is a need to assess the benefits and costs of road-friendly vehicles.

*Bridge limitations and costs*

- What is the magnitude of the dynamic factors of the live load and what are their effects on bridge design?
- What is the capacity of the national bridge stock?
- There is a need to quantify bridge costs as a function of vehicle axle and gross loads.
- There is a need to quantitatively assess the influence of frequency matching on bridge life and bridge maintenance costs.
- There is a need to assess the effectiveness of road-friendliness under conditions of gross overload.

*User charges*

- What are the most equitable and efficient methods that can be used for cost allocation?

To summarise, in response to the most important issues arising from the survey, the stakeholders of the DIVINE Project were particularly interested in:

- quantifying the benefits of road-friendly vehicles in terms of extended pavement life and reduced maintenance costs related to trucks;
- improving pavement design for trucks; and
- improving freight transport productivity.

## **II.2 Scientific basis of the DIVINE Project**

### **II.2.1 Background**

In 1992, an OECD Scientific Expert Group produced a technological perspective of the dynamic relationships of heavy vehicles to pavement performance and bridge response. The report included recommendations for international research co-operation aimed at determining the true significance of vehicle dynamics for pavement life and costs, and for providing vehicle assessment methods. The DIVINE Project developed as a result of this scientific review which gave a comprehensive account of the dynamic loads applied by vehicles to pavements and bridges.

As the DIVINE Project was being initiated, it became apparent that its strong focus on policy outcomes would require a broadened scientific base. In order to discuss road costs and user costs, the Project needed to address the realistic impacts of the interactive effects between the pavement and vehicle. To accomplish this, it was necessary to make use of certain terminology describing vehicle/pavement interaction effects. To this point in the report, use of these terms has been associated with either pavements or bridges, namely, wear, response, remaining life, deterioration, damage, pavement longitudinal profile, ride comfort, unevenness, roughness, structural variability and road condition. In many cases the individual meaning of these words appears relatively straightforward, but they have been used in a variety of ways and to connote different meanings. Therefore, the meanings of these words and other associated terminology are presented in the following paragraphs to familiarise the reader with the overall context in which such terms are used in this report.

Addressing the issue of *pavement performance*, which is often considered in the context of pavement predictive models, was central to the objectives of the DIVINE Project. *Pavement primary response* and *pavement damage response* are key parameters in pavement design procedures and in models developed to predict the deterioration of pavements over time. While these concepts were reviewed in the 1992 OECD study, a brief description of *primary response* and *damage response* is included in this report. These concepts also had their origin in the AASHO Road Test and have been developed through *empirical* or *mechanistic pavement design* procedures and *pavement predictive models* (see Annex A for more detail).

More recently, *Accelerated Pavement Testing* and *Long-term Pavement Performance* investigations have specifically included the effects of *non-uniformity* in pavement construction and materials, the introduction of new, or innovative, materials such as polymer modified binders, and the use of non-standard or marginal materials and by-products such as slag and fly-ash.

## *II.2.2 Dynamic loading of pavements and bridges*

The OECD report on *Dynamic Loading of Pavements* (1992) described the current state of knowledge of the topic and formed the basis for the DIVINE project. The main findings of the report are discussed here with a more detailed commentary on those aspects that were especially relevant to DIVINE.

### *Nature of dynamic loading*

As a result of a variety of static and dynamic processes, heavy vehicles apply wheel loads to roads and bridges that are higher than might be expected based on nominal axle loads. The static component depends on the total weight of the vehicle and its axle configuration and is very significantly influenced by the legal axle and gross vehicle weight limits adopted in various countries. The dynamic component depends on the vertical dynamics of the vehicle -- including such factors as the mass and stiffness distribution of the vehicle's structure, payload mass distribution, suspension and tyres -- and on the road surface's longitudinal profile and the speed of the vehicle. Vertical vibrations cause the loads applied by the wheels to the road to vary above and below their static values.

Typical magnitudes of dynamic wheel loads, when expressed statistically as a standard deviation, ranged between 5 - 10 per cent of the static load for well-damped air suspensions and for soft, well-damped, steel leaf suspensions. They ranged between 20 - 40 per cent of the stationary constant load for less road-friendly suspensions. The magnitude of the dynamic wheel load generally increased with both speed and road unevenness (OECD Road Transport Research, 1992).

Most heavy commercial vehicles generate their dynamic wheel loads either in the 1.5 - 4 Hz frequency range associated with body bounce or pitch motions, and/or in the 8 - 15 Hz frequency range associated with axle-hop vibrations. Axle-hop vibrations are more significant if the pavement is rough and the vehicle speed is higher than approximately 40 km/h.

The magnitude of dynamic loads and their frequency content are both of potential significance to pavement wear. The DIVINE Project adopted the Dynamic Load Coefficient (DLC) as a prime measure of dynamic loading, and considered both low-frequency (1.5 - 4 Hz) and high-frequency (8 - 15 Hz) loading. The DLC is defined (OECD Road Transport Research, 1992) as the ratio of the root mean square (RMS) dynamic wheel force to the mean wheel force, where the RMS dynamic wheel force is essentially the standard deviation of the probability distribution (see Figure II.1). The DLC is hence the wheel load coefficient of variation. The mean value of the probability distribution reflects the constant (static) component of the wheel loading and varies with local road transport regulations and other factors.

The impact factor, another measure of dynamic loading, is also used in the report. The impact factor for an axle is calculated as the ratio between the measured impact force on a sensor divided by the static axle load. Likewise the impact factor for a vehicle is the sum of measured axle impact forces on a sensor divided by the static gross vehicle weight.

### *Pavement design*

There are three major types of pavement systems depending on the materials used:

- *flexible*: a bituminous concrete or chip seal surfacing laid on unbound materials or materials bound with a binder;
- *rigid*: a Portland cement concrete surfacing laid on layers of bound or unbound materials; and
- *semi-rigid (or composite)*: a bituminous concrete surfacing laid on materials bound with a cementitious binder.

**Figure II.1. Definition of Dynamic Load Coefficient (DLC) (OECD, 1992)**

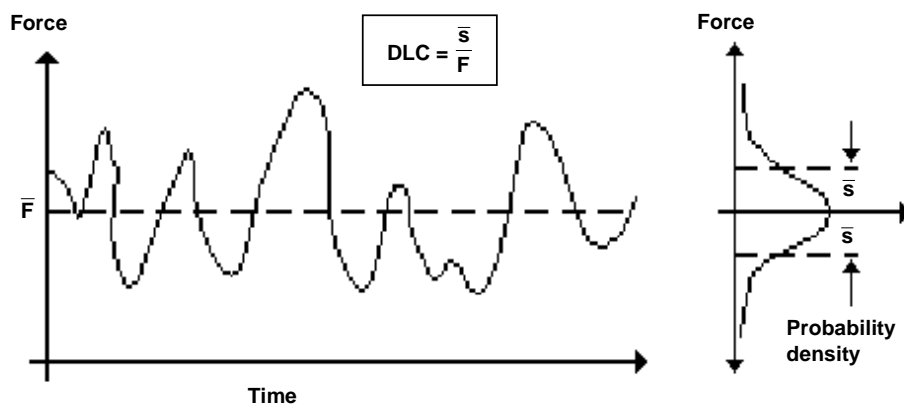

Source: OECD Road Transport Research, 1992.

Because of the prevalence of the flexible pavement type in recent and current road construction, emphasis in the DIVINE Project was placed on testing this type of pavement. The materials composing the individual layer are classified as being elastic, viscoelastic or plastic depending on their behaviour as determined under laboratory testing.

Pavements are designed to resist the repeated action of moving constant and moving dynamic load repetitions which will eventually cause fatigue and cracking of bound (i.e. bituminous or cemented) materials in all types of pavements and permanent deformation of all layers (bound and unbound) in flexible pavements. The way in which pavements respond to these repeated moving loads depends on the magnitude, speed, frequency, rest period and number of applied loads, on time-varying material properties and environmental conditions such as temperature.

The only pavement specifically constructed for the DIVINE Project was that tested at the Canterbury Accelerated Pavement Testing Indoor Facility (CAPTIF) which is an indoor, circular test track owned by Transit New Zealand and located at the University of Canterbury, New Zealand. This pavement, which was composed of a bituminous surface and a granular basecourse and subgrade, was designed for equal probability of failure by: (i) cracking of the bituminous surface layer and (ii) permanent deformation, or rutting, of the subgrade layer. Extensive pavement instrumentation was used to measure layer vertical deflections and the horizontal tensile strains at the base of the bituminous surfacing (a predictor of cracking) and the vertical compressive strains in the subgrade (a predictor of rutting).

### *Pavement wear*

***Pavement wear*** -- used here as an expression of the rate of progression of the various modes of the measurable distresses -- is of particular importance when addressing the vehicle-pavement interaction impacts. (The term pavement wear is sometimes applied to the deterioration of pavement surface properties such as skid resistance, but in the remainder of this report it will be used as defined above.) For roads subject to fatigue cracking, pavement wear is exponentially related to wheel load, perhaps according to a fourth-power relationship. In the case of roads subject to permanent deformation, the pavement wear relationship also has a “power” relationship, perhaps as low as unity (OECD Road Transport Research, 1992).

It was concluded in the OECD report (1992) that no studies had been carried out to either experimentally compare the effects of dynamic versus static wheel loading or to experimentally determine the effects of vehicle characteristics on pavement wear. This had important consequences for the initiation of the DIVINE Project. In developing the DIVINE Project, the Expert Group decided that it would not be feasible to compare the effects of dynamic versus static loading. Instead, the CAPTIF accelerated dynamic loading facility was commissioned to compare the effects of a road-friendly suspension (with notional low dynamic loading) with the effects of a non-road-friendly suspension (with notional high dynamic loading).

### *Functional condition, structural condition, serviceability and performance*

Fundamental to the conduct of the DIVINE project, and the interpretation of the results, was an understanding of the terms associated with the overall ***condition*** and ***performance*** of a given road (see also Annex A).

The ***condition*** of a pavement can be described from the viewpoints of both the road user, who is concerned with the “*ride quality*” and *safety* of the pavement (i.e. its function as a road surface) and the engineer, who is not only concerned with the current *functional* condition of the pavement, but also with its *structural* condition.

***Serviceability*** is one measure of *functional condition*. It is the ability of a specific section of pavement to serve traffic in its existing structural condition (Haung, 1993). In this context, serviceability is a functional condition measure prescribed by the user to meet current functional demands. The serviceability term itself is, however, composed of measures of the structural condition of the pavement. There are two ways to determine serviceability. One is to use the Present Serviceability Index (PSI), developed by AASHO, which is based on roughness, as well as cracking, rutting and patching. The other way to determine serviceability is to use a roughness index based on roughness only. All three definitions (*structural condition*, *functional condition* and *serviceability*) are, however, descriptions of these measures at a single point in time. The *time representation* of any of these three measures is given by use of the term ***performance***.

The *ride quality* of a road depends mainly on the current evenness of the pavement. It affects both driver comfort and road user costs because, as the pavement becomes more uneven, vehicle maintenance costs, fuel costs and travel time all increase. Safety may also be affected through decreases in skid resistance, aquaplaning as a result of retained water on the surface, spray from other vehicles and other factors. Other parameters affecting ride quality include noise, tyre wear and rolling resistance.

The *structural condition* is a measure of the current degree of severity of the defects or of the distress, visible or non-visible that has occurred in the pavement. It depends on the *thickness* of the various layers and on the type and strength of the materials contained in that pavement. It also depends upon the quality of construction of the road and in this context upon the degree of *variability* of the structural integrities of the layer materials along the length of the road. For example, a road having a high degree of material variability, yet constructed with a perfectly smooth (even) pavement surface, will very quickly degenerate to one exhibiting a rough (uneven) pavement surface. A pavement constructed with the highest quality and uniformity of materials could also, as a result of the construction process, exhibit a very rough or uneven surface. In either case the rough (uneven) road will exhibit poor ride quality and eventually induce very high dynamic loadings which will accelerate the further deterioration of the pavement.

Ullidtz (1987) explained why *functional* and *structural* conditions should not be described in one unique “index”. As shown in Figure II.2, pavement 1, with a poor functional but good structural condition, may have the same “condition index” as pavement 2, with good functional but poor structural condition. However, the *performance* of these two pavements may be very different. It should be remembered that the AASHO definition, given by the Road Test Equation, is a functional measure which employs visible measures of distress and should not be used in general to describe the degree of physical distress or the structural condition of the pavement.

**Figure II.2. Difference between “functional condition” and “structural condition”**

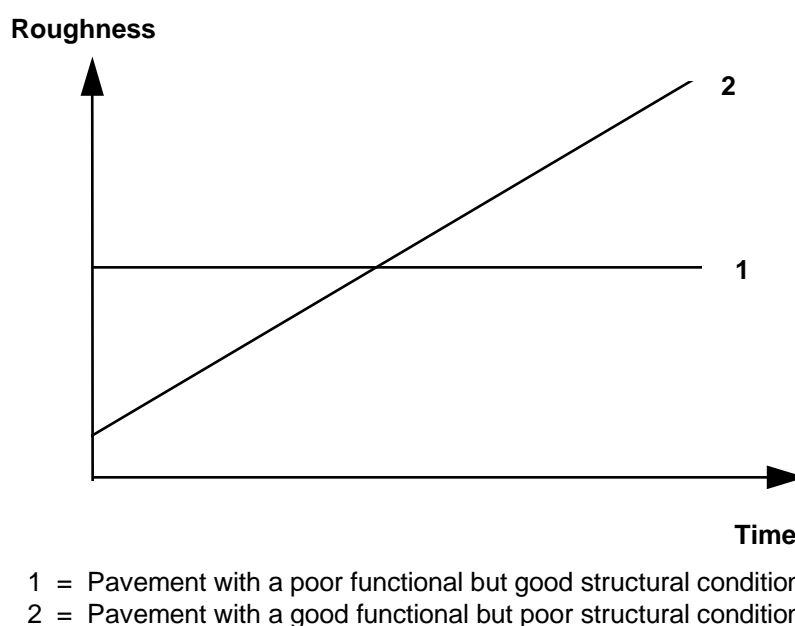

Source: Ullidtz, 1987.

#### *Spatial repeatability*

In simple terms, *spatial repeatability* is the tendency for a vehicle to impose the same loading during different passes on a road surface with a given profile. There is also the potential for dynamic loads under mixed traffic to concentrate at particular points on the road surface, perhaps bringing about

excess pavement wear. If the dynamic load is higher than the static load, and if dynamic loads do accumulate at certain points on the road, then there are obvious implications for both the vehicle design and the level of surface profile quality that should be achieved at construction in order that these higher dynamic loads can be minimised.

The spatial repeatability of dynamic wheel-loads is expected to depend on both the road surface profile and the extent to which the dynamic characteristics of the vehicles making up the heavy vehicle fleet tend to be homogeneous.

The DIVINE Project studied spatial repeatability at heavily trafficked highway sites in France and in the United Kingdom. The influence of longitudinal road profile and the characteristics of individual vehicles, and the statistical repeatability of dynamic loading from heavy vehicles occurring in mixed traffic, was considered.

### *Bridge response to dynamic loading*

Besides static deformations, highway bridges also exhibit dynamic responses to the passage of heavy commercial vehicles. This fact was established about 150 years ago when investigations into this matter were first performed in the context of severe accidents with railway bridges (Willis, 1851). Related developments between 1847 and 1990 have also been described (Cantieni, 1983 and 1992). Research into the dynamic responses of highway bridges has significantly intensified in the last 30 years with the development of modern measurement, data acquisition and data processing methods (Barbour, 1993, Jacob and Carracilli 1983). Newly developed bridge loading codes take these dynamic effects into account (Eymard *et al.*, 1990). The part of the DIVINE project related to the response of bridges to dynamic loading was based on the technology presented in these reports.

The dynamic response of bridges is a function of many parameters. These parameters include, bridge natural frequencies and damping, road profile, vehicle speed, mass, axle configuration and suspension, tyres, and the number of vehicles simultaneously on the bridge. To further complicate the issue, significant and important interactions between these elements can and do occur.

The main result previously reported (Cantieni, 1992) is that bridges with a fundamental natural frequency  $f \approx 2.5 - 4$  Hz (maximum span  $L \approx 40 - 25$  m) are more susceptible to the dynamic actions of heavy commercial vehicles (equipped with steel leaf suspensions) than bridges with a fundamental frequency lying outside this range. This difference is due to the fact that the wheel loads of such heavy vehicles show a predominant frequency content in this same range (Cantieni, 1992). This effect is known as “frequency-matching”, leading to dynamic amplification of the corresponding strong dynamic bridge response, a phenomenon referred to as “quasi-resonance”.

The 1992 OECD study demonstrated that developments in heavy vehicle suspensions are resulting in a decrease in the body bounce frequencies from  $f \approx 2.5 - 4$  Hz to  $f \approx 1.4 - 1.8$  Hz. This raised questions regarding the consequence of frequency matching between medium-span bridges ( $f \approx 1.4 - 1.8$  Hz, maximum span  $L \approx 80 - 60$  m) and these lower body bounce vibrations.

The data presented in the 1992 OECD report also highlighted the fact that axle hop components ( $f \approx 8 - 15$  Hz) of the dynamic wheel forces can also be significant, especially when the road profile exhibits short wave-length roughness and the vehicle speed is greater than 40 km/h. Frequency matching between axle hop and short span bridges (maximum span  $L \approx 8 - 15$  m) was anticipated but only a small

number of tests had been conducted using short-span bridges to confirm this expectation. For example, those codes of practice that express the dynamic load allowance for bridge design as a function of fundamental frequency usually do not consider bridges with frequencies in excess of 6-10 Hz. Thus the key research questions for short-span bridges related to understanding the response to both conventional steel leaf suspensions and softer air suspensions.

The importance of pavement unevenness on dynamic bridge response was also well known before the DIVINE project commenced. The spatial frequencies (or their wavelength equivalent) evident in the profile generate the dynamic wheel forces with frequencies that vary with vehicle speed and vehicle geometry. Thus road profile and wheel-base filtering effects are important in understanding the influence of vehicle suspensions on the dynamic response of bridges.

#### *Vehicle design and operation*

The OECD (1992) found that approximately half of the heavy vehicle fleet consisted of rigid trucks with one or two driven axles. The second largest category in most countries was articulated trucks, the tractors usually having one or two driven axles, and the semi-trailers usually two or three axles. There were lesser, but significant, numbers of truck and trailer combinations, usually with two or three axles per trailer, and buses, which generally had one or two rear axles. Some countries had multi-trailer road trains with up to five axles per trailer.

The DIVINE Project made use of instrumented test vehicles which allowed single axles, tandem axles and tridem axles, as well as a complete five-axle tractor-semi-trailer, to be studied. The CAPTIF accelerated dynamic loading test was representative of a single axle only.

According to the 1992 survey, the majority of trucks in use in OECD Member countries, including rigid trucks, tractors, semi-trailers and road train trailers, had steel leaf suspensions, and most of these were high-friction multi-leaf types. The same study revealed that most buses had air suspensions. There was a significant trend towards the use of air suspensions in most Member countries, along with increased attention to the design of mechanical suspensions.

DIVINE test vehicles with both air and mechanical suspensions were used in bridge tests in Australia and Switzerland, and during spatial repeatability tests in France. The CAPTIF accelerated dynamic loading test provided a direct comparison of air and mechanical suspensions for a single axle under controlled conditions.

It was also reported by the OECD (1992) that most heavy vehicle axles were fitted with dual-tyre arrangements, the only significant exceptions being steering axles which were usually fitted with single tyres of "normal" width (less than 310 mm) and semi-trailer tridem axles which were often fitted with "wide single" tyres (wider than 310 mm).

The test vehicles used in the DIVINE Project were mainly fitted with dual tyres. However, the CAPTIF accelerated dynamic loading test used wide single tyres on both carriages in order to accelerate the rate of pavement wear for both suspensions. A more detailed description of the facilities, equipment and vehicles used in the DIVINE Project can be found in Annex B to this report.

### *Effect of longitudinal profile*

The OECD (1992) found that wavelengths in the pavement surface which excite vehicle bounce and pitch at normal traffic speeds were in the range 4 - 20 m, whilst wavelengths which excite axle hop were in the range 1 - 4 m. The way in which the longer wavelengths in the pavement surface excite the dominant bounce and pitch motions of the vehicle depends on an interactive effect between the vehicle wheel-base dimensions and the vehicle speed. This effect is termed "wheel-base filtering".

Various means of measuring profiles were also reported by the Group. High-speed laser profilometers were used in the DIVINE Project whenever possible and both short and long wavelengths were considered in analyses of longitudinal pavement and bridge profiles.

### *Test techniques*

The 1992 OECD Group reported that, while the on-board measurement of dynamic wheel loading posed some problems, accurate and cost-effective means of measurement were available. Pavement-based measurement techniques were also available, including weigh-in-motion (WIM) systems (COST 323, 1995). Low-cost WIM sensors such as piezo-ceramic or capacitive strips have been developed and marketed in the last decade. The necessary data handling and analysis software has also become available, and the concept of multiple-sensor weigh-in-motion (MS-WIM) was introduced (Glover and Newton, 1991). This became an effective investigation tool for the study of the dynamic axle and vehicle loads on pavements (Cebon and Winkler, 1991). In addition, road simulators are increasing in their availability and use.

All of these techniques were used in the DIVINE Project. Five instrumented and calibrated test vehicles were utilised: two 2-axle rigid trucks [operated by the United States' Federal Highway Administration (FHWA) and the United Kingdom's Transport Research Laboratory (TRL)], a 3-axle rigid vehicle operated by VTT (Finland), a 5-axle tractor-semi-trailer [operated by the National Research Council of Canada (NRC)], and one 1-axle trailer (operated by Hannover University). Two instrumented test pavements (operated by the FHWA and VTT), were also used. Two MS-WIM arrays were built and operated by the Laboratoire Central des Ponts et Chaussées (LCPC), France, and TRL, in suitable sections of the public highway network. The road simulator operated by the NRC was also used in the DIVINE Project.

### *Computer simulation*

The 1992 OECD report found that techniques for simulating vertical dynamics and predicting dynamic wheel loads are relatively accurate and well developed. However, these methods had not been adequately cross-referenced nor tested in a wide enough environment to permit the recommendation of methods for vehicle assessment on a national or international basis. Furthermore, there was a need to ensure the proper validation of these models against measured data obtained under real conditions. A number of existing models were assessed by the DIVINE Project to determine the generic features of a reliable model and to assist with the process of validation of such models.

### **II.2.3. Pavement structural design procedures**

#### *Empirical design*

Empirical design procedures have been adopted in many countries based on the subgrade California Bearing Ratio (CBR)/traffic/thickness-of-cover principles, adjusted to take account of local environmental conditions, traffic and pavement types (see Annex A). The limitation of empirical models is that they have been developed from regression analyses of experimental or observed data. For this reason, whilst these models are useful when the mechanism of pavement performance is not understood, they should not be used beyond the range of data from which the model was developed.

On the other hand, a limited survey of experienced engineers in Australia (Potter *et al.*, 1996) on design reliability has indicated that pavements designed with the Australian empirical granular thickness chart, which is based on the early Road Research Laboratory (United Kingdom) curves (1962) -- see also Annex A -- have a low probability of premature distress. Whilst there was a wide scatter of responses in the survey, the average response was that pavements designed in accordance with the chart had about a 85 per cent probability of exceeding the design traffic. In other words, there is an inherent conservatism built into these empirical design procedures.

#### *AASHO road test*

To take account of the magnitude and type of loads that a road will be subjected to during its design life, many attempts have been made to establish equivalency relationships between pavement performance and the magnitude of the axle load. A significant experiment in this regard was the AASHO Road Test. The principal objective of the AASHO Road Test research was to establish relationships between performance, structural design (i.e., component thicknesses of the pavement structure) and loading (i.e. the magnitude and rate of application of axle loads). The original axle load equivalency concept developed from the AASHO Road Test was expressed in the form of a "power law". Because a power of 4 was obtained from an analysis of the AASHO Road Test data, the law became known as the "fourth power law" -- see also Annex A.

For the same reasons that empirical design procedures should not be used beyond the range of data from which the model was developed, the use of the "fourth power law" may not be appropriate in all situations unless the environment, traffic, pavement type and pavement construction methods are the same as, or very similar to, those in the AASHO Road Test. In addition, vehicle damage factors derived from the AASHO Road Test may not give an indication of long term pavement performance which depends on a range of other factors.

#### *Mechanistic design*

Pavement design has evolved from an empirical approach to a more fundamental approach where the pavement is treated as a civil engineering structure. With knowledge of the properties of the constituent materials, this approach allows an analysis of, firstly, its *response* to an applied load -- i.e. the stresses, strains and displacements developed in the structure in response to the applied load -- and, secondly, its *performance* when subjected to many repetitions of the applied load -- i.e. the progressive deforming of all materials and the initiation and progression of cracks in bound (bituminous or cemented) materials. Various performance models have been adopted to predict long-term pavement behaviour.

### *Accelerated pavement testing*

There has been a trend in recent years for road agencies to conduct major research programmes in which “in-service” long-term pavement performance (LTPP) monitoring is combined with full-scale accelerated pavement testing (APT) and laboratory materials characterisation in an attempt to better understand road pavement performance.

The primary application of APT has been the empirical comparison of different pavement configurations and materials under different loading configurations, the results of which form the basis of current pavement design and material selection procedures. A secondary application has been the evaluation of theoretical models of pavement response and material behaviour.

By its nature, APT is unable to take account of the interaction of environmental factors and loads, and in particular the deterioration of pavement materials with exposure to sun, water and time. There is significant evidence that the environment in which a load is applied -- especially with regard to the presence of moisture and extremes of temperature -- has a major influence on the deterioration effects of the load.

APT was adopted in Element 1 of the DIVINE Project because the main objective was to compare the performance of a well-defined flexible pavement under two suspension types and, as such, to “rate” the suspension systems. Such a study could not have been attempted using a long-term field trial because, apart from the time required to collect the data, control of the trafficking conditions (i.e. ensuring that the same load was applied to the same section of pavement by two different suspension systems), control of the environment and tight control over the construction process would have been impossible. On the other hand, it was imperative that the APT study be conducted in association with other studies, not only in Element 1 (laboratory characterisation, suspension characterisation, etc.) but also with the other Elements if an improved understanding of the interaction between the dynamic wheel load and the road was to be gained.

#### ***II.2.4. Life-cycle costing***

Pavement life-cycle costing (LCC), or whole of life costing, allows all costs over a pavement life to be compared and creates the potential for economically efficient pavement costs to be attributed to road users. Economic efficiency is achieved if total costs over the life (including user and external costs) are minimised. In practice this means that either existing or new pavement expenditure options are examined for their relative economic merits. There are many possible categories of costs and cost differentials, or potential savings, that can be considered in LCC (Sayers, 1978). In general terms, however, the following cost categories should be considered in life-cycle costing:

- The cost categories including the initial capital and the anticipated rehabilitation and ongoing maintenance expenditures that the road agency will incur over the economic analysis period of each LCC option. The external costs of accidents, pollution and noise should also be quantified and included.
- The cost differentials including the travel time savings with respect to the existing travel time (for new facilities), vehicle operating cost savings with respect to the existing costs (for new and existing facilities) and any other quantifiable external benefits or savings generated.

A parametric study was recently undertaken in Australia (Martin, 1996) to examine the influence that pavement performance has on pavement life-cycle costing, considering total costs (road user costs plus the road agency costs of maintenance and rehabilitation) in a net present value (NPV) analysis over a 30 year period. The study used a defined model network composed of lengths of defined arterial roads, each at a given state of average road evenness and subject to average levels of traffic. It was found that lowest total costs would be obtained by carrying out rehabilitation according to a strategy of constraining the maximum road roughness.

An unconstrained budget total cost analysis demonstrated that, if road user costs were included in the total cost optimisation process, there were no total benefits in allowing the network to deteriorate beyond a NAASRA Roughness Meter value of 150<sup>1</sup>. Reduced rates of pavement deterioration led to significant reductions in total costs, arising mainly from road authority savings in rehabilitation costs, while increased rates of deterioration led to significantly increased costs, arising from the same source.

The annual road agency costs in a pavement LCC analysis are highly dependent upon the predicted rate of pavement deterioration. For example, the Australian parametric study found that the variation in annual road agency costs from those related to a “base rate” of pavement deterioration represented an increase of 45 per cent for a high rate of pavement deterioration and a decrease of 32 per cent for a low rate of pavement deterioration.

As the above results show, highly significant variations in annual road agency costs over a pavement life-cycle occur depending on the observed variations in pavement deterioration. This is a cause for concern as the prediction of pavement deterioration as influenced by varying maintenance activity is currently not known in quantitative terms. This outcome reinforces the need to develop accurate pavement performance models that can predict pavement performance due to varying levels of maintenance activity because pavement LCC and asset management do not currently have a substantial quantitative basis from which to demonstrate that existing road agency costs and levels of intervention are economically efficient.

Based on these results, if higher dynamic loads lead to higher rates of pavement deterioration, clearly there may be significant costs to road agencies and to the broader community. On the other hand, if dynamic loads can be reduced by encouraging the use of road-friendly suspensions which, in turn results in a reduced rate of pavement deterioration, the savings may be significant. An improved understanding of the interaction of vehicles and the infrastructure, and in particular dynamic loads and the rate of pavement deterioration, is also required to advance LCC techniques.

### ***II.2.5 Influence of pavement non-uniformity -- Methods of analysis***

It is well known that, during the construction of a pavement, variations in layer material quality, moisture content and homogeneity, as well as variations in construction technique, can all result in non-uniformities and longitudinal and lateral variations in the pavement structure. At times, this spatial variation may be significant in terms of both the functional and structural performance of the pavement. This is because, as vehicle loads are applied to the pavement, these spatial variations can result in the development of non-uniform spatial distributions of stress, strain and displacement within the pavement, which in turn can cause non-uniform distributions of defects within the pavement. These defects are eventually manifest as visible differences in pavement distress, e.g. some areas of the pavement surface

---

1. There are a number of conversion formulae between NAASRA Roughness and IRI. A typical “equivalent IRI” value for a NAASRA Roughness of 150 would be 4.4 m/km (Prem 1987).

will have a greater intensity of cracking than others and/or the extent of permanent deformation along the wheelpaths can vary. External influences such as the infiltration of water into the pavement, drying out of the pavement materials or freeze-thaw cycles will of course also contribute to non-uniform distribution of defects.

It was therefore imperative in the DIVINE project, especially in Element 1, to distinguish between pavement distresses resulting from any non-uniformities in the pavement and those directly related to the dynamic loads imposed on the pavement as a result of the tyre-suspension dynamics.

Major effort was therefore placed on ensuring, as far as possible, that the quality of the materials placed in the CAPTIF pavement and the construction method were as uniform as possible. This required that an extensive laboratory testing programme be conducted on the pavement materials to check their compliance with the specifications, and that extensive testing be conducted on all layers during construction to ensure that the quality of the as-placed layers met compaction and thickness requirements and that the variation in these properties was as small as possible.

Following construction, but before trafficking commenced, extensive surveys were conducted using a Falling Weight Deflectometer (FWD), the output of which (deflection bowls) represented the combined effects of material variability (thickness, compaction, moisture content, etc.) existing in the subgrade, base and bituminous surface layers. Not only was it imperative to ascertain the degree of variability along each wheelpath but also, and most importantly, the degree of variation between the two wheelpaths. FWD surveys were also conducted on all layers as they were placed.

## BIBLIOGRAPHY

- BARBOUR, I.A. (1993), *Multiple-sensor Weigh-in-Motion Trials at Abingdon (A34)*, Research Report 375. Transport Research Laboratory, Crowthorne.
- CANTIENI, R. (1983), *Dynamic load tests on highway bridges in Switzerland - 60 years experience at EMPA*, Report No. 211. Swiss Federal Laboratories for Materials Testing and Research (EMPA).
- CANTIENI, R. (1992), *Dynamic Behaviour of Highway Bridges under the Passage of Heavy Vehicles*, Report No. 220. Swiss Federal Laboratories for Materials Testing and Research (EMPA).
- CEBON, D. and WINKLER, C.B. (1991), "Multiple-sensor Weigh-in-motion: Theory and Experiments", *Transportation Research Record No. 1311*, pp. 70-78. TRB, Washington DC.
- COST 323 (1995), *Pre- and Post-Proceedings of the first European Conference on Weigh-in-motion of Road Vehicle*, March 8-10, Eds B. Jacob. ETH, Zurich.
- EYMARD, R., GUERRIER, F. and JACOB, B. (1990), "Dynamic Behaviour of Bridges under Full Moving Traffic", April-May, *US-European Symposium on Bridges*, Baltimore.
- GLOVER, M.H. and NEWTON, W.H. (1991), *Evaluation of a Multiple-sensor Weigh-in-motion System*, Research Report 307. Transport Research Laboratory, Crowthorne.
- HAUNG, .H. (1993), *Pavement Analysis and Design*, Prentice Hall, New Jersey.
- INTERSTATE COMMISSION (1989), *Road User Charges and Vehicle Registration: A National Scheme*, Australian Govt. Printing Service, Canberra.
- JACOB, B. and CARRACILLI, J. (1983), *Mesure et Interprétation des Charges Dynamiques dans les Ponts - Etude de la Fatigue*, Rapport final de recherche, CECA 7210KD311. July, LCPC, Paris.
- MARTIN, T.C. (1996), "A Parametric Study of the Influence of Pavement Performance on Life-cycle Costing", ARRB Transport Research, Working Document WD TI 96/019, June, ARRB.
- OECD ROAD TRANSPORT RESEARCH (1992), *Dynamic Loading of Pavements*, OECD, Paris.
- OECD ROAD TRANSPORT RESEARCH (1994), *Road Maintenance and Rehabilitation: Funding and Allocation Strategies*, OECD, Paris.
- POTTER, D.W., JAMESON, G.W., MAKAROV, A., MOFFATT, M.A. and CROPLEY, S.M. (1996), "A Basis for Incorporating Reliability in the AUSTROADS Pavement Design Procedures", ARRB Transport Research Working Document WD TI96/014, June, ARRB.
- PREM, H. (1987), "Road Roughness Influence on Suspension Performance", *Proceedings ARRB Symposium on Heavy Vehicle Suspension Characteristics 23-25 March*. Australian National University, Canberra, A.C.T
- SAYERS, C.R. (1978), "Optimisation in the Transport Sector: A Much Neglected Objective", *Proceedings 4th Australian Transport Research Forum*, 24-26 May, Perth.
- ULLIDTZ, P. (1987), *Pavement Analysis*, Developments in Civil Engineering, 19. Elsevier.
- WILLIS, R. (1851), "An Essay on the Effects Produced by Causing Weights to Travel over Elastic Bars", Addendum to Barlow, P. *A Treatise on the Strength of Timber, Cast and Malleable Iron*, John Weale, London.

## CHAPTER III. THE VEHICLE-INFRASTRUCTURE SYSTEM: A NEW APPROACH

### III.1 Introduction

For many years, certain methods have been used to relate the deterioration of components of the highway infrastructure to the effects of the vehicles that use them. Pavement design methods, for example, have recognised the effects of heavy goods vehicles on road pavements by including relationships between the static weight of vehicles and their axle loads, and the “road damage” they cause. These relatively simple relationships have been enhanced over recent years through the development of a more mechanistic approach to pavement design based on material characteristics and their response to imposed moving static loads rather than to the dynamic loads which occur in practice. A lack of knowledge and information has impeded the development of still more advanced methods of pavement design capable of responding to the changing regime of dynamic loads that is likely to arise during the service life of the road.

The situation has developed somewhat differently for bridges. In the middle of the last century, in the case of railway bridges, it was deemed insufficient to consider only the static load effects. Thus, the Dynamic Load Allowance for railway bridge loads was defined as being a function of the bridge average span. On this basis, highway bridge loading at the beginning of the century made use of this philosophy. By the 1970's, the experimental and computational methods were sufficiently developed to prove that the dynamic bridge response to the actions of heavy vehicles is mainly a function of the bridge fundamental natural frequency, on the one hand, and of the frequency content and magnitude of the dynamic wheel loads exerted by the vehicle during its passage over the bridge, on the other hand. Today, it is felt that further work is necessary to bring about a greater understanding of the vehicle/bridge interaction and to account for vehicle types, suspensions and longitudinal profile (see Annex A for further detail on the development of bridge design/vehicle dynamic interaction).

While pavement and bridge design methods have progressed relatively slowly, developments in vehicle design and technology have been relatively rapid and market-led, resulting in improvements in efficiency, safety and environmental impact. The development of air suspension systems was brought about primarily by consideration of operator needs, while their potential effect on pavement and bridge life became apparent only at a later date. While few aspects of heavy vehicle design specifically take into account the consequences for infrastructure, the capacities of axles, suspensions, tyres and inter-axle spacings are dictated by weight limit regulations.

It is clear that the design, operation and maintenance of the components of the vehicle-infrastructure system are in fact highly interdependent. It is also clear that the needs of the infrastructure owner, often a local or national government agency, must be balanced against those of the road user, and particularly those of the road transport industry. To fully achieve this, a new approach that considers the vehicle and infrastructure together as an interactive dynamic system needs to be used. In order to

optimise some key characteristics of this system and its overall performance and balance, it is necessary to consider how the system can be effectively modelled. This requires a deeper understanding of the system than is currently available.

The DIVINE Project was the first such approach specifically designed to address the vehicle-infrastructure system by considering it in a more integrated way. Each Element of the DIVINE project was designed to contribute to this deeper understanding. In order to provide a comprehensive description of the vehicle-infrastructure system, Sections III.2 and III.3 identify the essential components of pavements, bridges and vehicles and the principal characteristics of their interactive behaviour. Section III.4 presents conceptual models of the vehicle-pavement and vehicle-bridge systems; and Section III.5 provides a summary description of the various research elements of the DIVINE Project.

## **III.2 System components**

### ***III.2.1 Pavements***

As already discussed in Chapter II, the DIVINE Project concentrated on flexible pavements. Flexible pavements are commonly used in heavy duty applications and are therefore potentially more vulnerable to the cycle of dynamic loading and roughness changes. Their composition, typically viscoelastic bituminous materials and stress-dependent granular materials, also makes their response to dynamic loading more complex.

The *surfacing* of a flexible pavement is generally a relatively stiff bituminous bound layer. It may deform by (i) rutting (i.e. by compression and plastic flow of this layer or one or more of the layers below the surfacing) or (ii) cracking (i.e. bending). The typical modes of deterioration of the surfacing will be longitudinal or transverse cracking and accumulated local deformation leading to rutting. The extent of cracking, or the development of rutting, is an important indicator of pavement condition.

The *basecourse* of the flexible pavement is the strong layer in its construction. It can comprise unbound granular or bituminous material, depending on the service duty required or the availability of materials. In service, deterioration of the basecourse can be brought about by compressive or shear failure, depending on the type of basecourse, leading to settlement of granular bases and deformation of bituminous bases. Again, the extent of these deformations is a critical indicator of the structural condition of the layer. In the case of bituminous bases, pavement design methods often consider fatigue of the bituminous base as a prime mode of distress.

The *subgrade* is the least stiff “layer” of the pavement. It is the material that the remainder of the pavement is designed to protect by distributing applied wheel loads so that compressive stresses and strains are reduced and maintained to a level below the critical stress for the particular subgrade concerned. Subgrades are typically comprised of fine-grained clays or sands, the former often being most susceptible to moisture. Strictly speaking, the subgrade is not a pavement layer because it is the upper part of the earthworks. However, it is essential to include the subgrade in the vehicle pavement system.

### ***III.2.2 Bridges***

Although a multiplicity of bridge designs exist, they may all be characterised as mechanical systems in which the most important parameters (in the present context) are the static system (span

lengths, continuity between spans, boundary conditions), the mass and the flexural and torsional stiffness of the bridge superstructure. These parameters determine the natural frequencies of the bridge. This applies for monolithic bridge structures as well as for structural components of bridges assembled from various components. Such components will include the bridge deck, the beams (main girders and cross beams) and the cables in the case of cable-stayed and suspension bridges. Sub-structural elements such as piers and abutments that are not well separated from the bridge superstructure also significantly influence the bridge dynamic properties. Besides the natural frequencies of the bridge, the associated damping capacity may be of importance, especially for short-span bridges. Monolithic superstructures which are well separated from the sub-structural elements are weakly damped (up to 1 per cent of critical) whereas structures composed of many elements closely connected to the sub-structure exhibit stronger damping (more than 1 per cent of critical).

Frequency-matching and the longitudinal profile of the bridge deck and approaches are the main parameters in the vehicle/bridge interaction process. The approaches to many bridges become rough due to differential settlement and, in addition, the joints between the bridge superstructure and the approaches (or between individual spans) are often of relatively poor quality. This is of great importance for short-span bridges, whereas for medium- to long-span bridges the dynamic wheel loads excited by such longitudinal profile features are usually attenuated by the bridge and damped by the vehicle before the vehicle reaches a critical bridge section.

### **III.2.3 Vehicles**

The gross weight and axle loads of the vehicle are the loading parameters which are traditionally considered when designing a road or a bridge. Although an appreciation of the effects of other parameters has grown, it has not yet been possible to quantify these effects in a way which contributes to the development of an overall model of the behaviour of the vehicle-road system. The situation is somewhat better when dealing with bridge design because experimental as well as numerical methods are currently at an advanced stage. There are a number of vehicle characteristics which affect the interaction of the vehicle with pavements and bridges and the most important of these are described below.

The *tyre* acts through its pneumatic and mechanical properties to envelop and absorb small disturbances, spread the wheel load over an acceptable area of the pavement surface and provide vertical springing. Its performance, *vis à vis* both the vehicle and the pavement, is highly dependent on the inflation pressure and the wheel load. The tyre load and the distribution of compressive stress in the “contact patch” or “footprint” are important indicators of tyre response and of potential pavement response. Tyre performance depends critically on the selected size designation and inflation pressure in relation to the load carried. For a given load, dual tyre assemblies generally have a larger total contact patch and apply lower compressive stresses than wide single tyres. Tyre type has been shown to be very important to the performance of the road to which it is applied.

The *axle* adds a relatively large mass between the tyre and the vehicle suspension, and contributes to axle hop motions which occur at relatively high frequencies.

The *suspension* provides springing and damping between the axles and the body of the vehicle. Considerable advances have been made in recent years in the technology of suspension systems. For example, air bag suspensions provide a relatively low stiffness and therefore a relatively low bounce frequency for a given axle load. They also offer a smooth, progressive deflection characteristic under load. Damping of air suspensions is provided by hydraulic “shock absorbers” which are subject to wear and eventual loss of effectiveness.

Most mechanical suspension systems have a higher stiffness and friction than air suspensions. This leads to sudden deflection under load. Friction causes steel leaf springs to remain “locked” as long as the pavement is smooth and/or the vehicle speed is moderate. Under these circumstances, the vehicle vibrates on the tyres only with the result of a relatively high spring stiffness and low damping. If the pavement becomes rougher and/or the vehicle speed increases, the steel leaf springs begin to unlock, the spring stiffness decreases and the suspension damping capacity increases significantly. As a result, the wheel load frequency content of steel-suspended vehicles can vary in a rather wide range. The damping capacity of such suspensions therefore depends strongly on the excitation amplitude. Damping will be higher in the case of high amplitude excitation.

Newer designs of steel spring suspension have improved low-friction characteristics. Here, the individual steel leaves touch each other at their ends only. The case where the steel leaf spring is completely locked cannot occur. The suspension spring stiffness is therefore lower than for a typical steel suspension in its locked state and shock absorbers have to be added because the damping capacity of the steel leaves is much smaller than for the traditional steel suspension mentioned above. As a consequence, the natural frequency of such a suspension varies over a much smaller range than for the traditional steel suspension. The wheel load frequency content, which is dependent on the road profile frequency content as well as the suspension frequencies, varies over a wider range.

*Axle groups* such as tandem or tridem axles usually allow for sharing and equalising load among the axles in the group. In the case of air suspensions, such sharing and equalising is, in principle, simple and effective and is accomplished by pneumatic inter-connection of the air bags on all axles. In the case of mechanical suspensions, the linkages comprising the load-sharing mechanism can be very effective in sharing the load between axles but can lead to additional suspension motions, particularly related to axle hop. Air suspensions tend to behave independently at axle hop frequencies because air flow between adjacent suspensions is limited at high frequencies.

The *sprung mass* represents the portion of vehicle load carried on the suspension. It has a dominant effect on the dynamic wheel load, particularly the portion related to the bounce of the sprung mass on the suspension and/or tyres.

### **III.3 Principal system characteristics**

Despite the overall complexity of the vehicle-infrastructure system, it is clear that a number of its characteristics are especially important to the behaviour of the system and its components and have therefore been taken into consideration in the DIVINE Project. These are described below.

#### ***III.3.1 Longitudinal pavement profile***

The longitudinal profile of the pavement influences the vertical excitation of the vehicle and the degree to which the sprung mass and axle motions -- causing dynamic loading -- are generated. The profile may be described as the change in elevation of the pavement surface with distance or in terms of the dominant wavelengths in the profile and their amplitudes (the Power Spectral Density (PSD) of the profile -- for example, the ISO specification of displacement power spectral density). Accurate measurement of profiles has advanced considerably in recent years. Laser profilometers and Longitudinal Profile Analysers (APL -- Analyseur de Profil en Long), using precise accelerometers and advanced signal processing methods, are now well-established techniques for this purpose. For international comparisons, indices such as the International Roughness Index (IRI) that contain guidance on definitions of degrees of

roughness, have been developed. Simple comparisons of PSDs, which may be linked to IRI, are also possible. The APL ratings provide specific information about the pavement unevenness in each wavelength range (low, medium and large).

### ***III.3.2 Dynamic wheel forces***

Dynamic wheel forces occur at the tyre-pavement contact area. They affect both the pavement and the vehicle and may be represented by their measured or computed time histories or by their PSD which shows the dominant frequencies involved. They may also be summarised statistically into a probability distribution function indicating the occurrence of high values -- i.e. the Dynamic Load Coefficient (DLC). Accurate measurement of these forces is challenging, and available methods vary in their precision. Of those available, instrumented vehicle axles provide a well-established and widely acceptable measurement technique, provided that adequate calibration is carried out.

Multiple-sensor weigh-in-motion (MS-WIM) systems using a sufficient number of sensors along a length of 25 to 50 m allow sampling of these dynamic forces. These systems -- originally introduced in United Kingdom (Glover and Newton, 1991; Cebon and Winkler, 1991) -- were used in France in the framework of Element 5 of DIVINE (Blab and Jacob, 1997). Development of such systems is continuing (Jacob and O'Brien, 1994). The sampled values may be used to estimate the statistics of these dynamic forces such as dynamic load coefficients, maxima or mean values. Furthermore, some advanced signal processing tools (signal reconstruction techniques) could be used to derive the wheel force time histories from these sampled values.

### ***III.3.3 Vehicle acceleration***

Vertical acceleration of the axles and the sprung mass provides a means of quantifying vehicle bounce and axle hop motions. The dynamic wheel forces are related, among other things, to these accelerations which may be represented as PSDs or may be further processed to estimate dynamic load coefficients.

### ***III.3.4 Pavement and bridge strains/deflections***

The strains and deflections generated in pavement layers and in bridge structures are a response of the pavement or bridge to the applied dynamic wheel loads. Although relatively reliable techniques exist for pavements, accurate measurement of these responses is difficult and their correct interpretation requires the application of a number of corrections or normalisations. Tensile and compressive strains may be measured in the surfacing, both longitudinally and transversely to the direction of travel. Compressive strains may also be measured in the basecourse and subgrade.

The technology for measuring deflection and strain in bridges is more accurate than is currently the case for pavements. Deflection measurement provides an insight into bridge behaviour as a whole, and is therefore the preferred technology when investigating aspects of Dynamic Load Allowance (DLA). Local strain measurements in bridges under traffic loads are quite common for steel and steel/concrete composite bridges where fatigue problems are to be investigated. In addition, strain measurements may provide fruitful information on the dynamic axle and vehicle loads applied to the bridge deck. This technique is closely allied to weigh-in-motion technology, and has been used in the United States and elsewhere as a measure of the traffic weights using the highway.

### ***III.3.5 Pavement modulus and bridge stiffness***

The application of a static or dynamic load to a pavement or bridge structure results in deformation of that structure. In the case of bridges, the deformation results from bending and can be measured, as stated previously, in a relatively straightforward and accurate way so that the flexural and torsional stiffness of the bridge can be derived. The hypothesis that bending takes place in pavements has been used to establish techniques to measure the deflection bowl resulting from the application of the load and from which the modulus of the pavement can be determined. The form of bending or deformation in pavements is subject to environmental factors because of the pavement construction materials. Periodic measurements of modulus or stiffness during the loading of a pavement or bridge may be used to indicate any weakening or change in the structure. Despite the application of sophisticated techniques, the accuracy of pavement modulus measurement in particular, remains limited. In the case of laboratory testing used to determine moduli, a further difficulty arises from the need to simulate field conditions (time of loading, etc.).

Dynamic pavement deflection measurement devices such as the Falling Weight Deflectometer (FWD) provide information on the unit pavement deflection, both locally under the applied load and at certain distances from the point of load application. This information can be analysed for each pavement layer individually or for the total pavement structure. The total deflection per unit of applied dynamic load under the FWD provides a fundamental measure of local pavement compliance (the opposite of stiffness or strength).

### ***III.3.6 Pavement distress***

Distress is the term normally used to describe the progressive deterioration of a pavement. It is frequently characterised by cracking at the surface or by rutting, which may involve any or all of the pavement layers. Rutting is expressed as the displacement from the original position of the surface of the pavement, whilst cracking is generally expressed as a total length of crack per unit area of the pavement. Distinctions may be made between longitudinal and transverse cracking.

The link between pavement distress and pavement strains/deflection is not fully understood, although models exist which attempt to explain and predict this relationship.

### ***III.3.7 Bridge fundamental natural frequency and associated damping***

The fundamental natural frequency and damping indicate the risk of frequency matching effects for a given dominant wheel load frequency acting during the passage of a heavy vehicle. Whereas the fundamental natural bridge frequency is important in all cases, damping is important for short-span bridges only as indicated in Section II.2.2. In the relatively rare case where the fundamental natural bridge frequency dominates the free decay process after the vehicle has left the bridge, the fundamental natural frequency value and associated damping coefficient can easily be determined from this free decay process. In the more usual case of the free decay process being dominated by more than one bridge natural frequency, more sophisticated methods to determine the bridge natural behaviour are available. These include Ambient Vibration Testing (AVT) and Forced Vibration Testing (FVT). Both methods yield the structure's complete set of natural frequencies and damping as well as the associated mode shapes in the frequency band of interest,  $f = 2 - 20$  Hz for example.

### III.4 Conceptual models

Conceptual models of the vehicle-pavement and vehicle-bridge systems form the basis of a new approach to the interaction of heavy vehicles and infrastructure. They also provide a framework for explaining the scope of the research carried out under each DIVINE Research Element. Further detail from the point of view of the system components studied and those aspects of interaction addressed by each Element of the DIVINE Project can be found in Section III.5.

#### III.4.1 *Vehicle-pavement interaction*

Figure III.1 illustrates the interacting components and key performance characteristics of the vehicle-pavement system in which a truck travels over a flexible pavement with certain characteristics of surface roughness and structural strength. A full physical description of all the relationships involved is challenging due to the complexity of the dynamic systems involved and the fact that some behaviour is spatially related, some is time-related and some is cumulative with regard to repeated passes of the vehicle. In simple terms, the pavement roughness initiates the vertical dynamics of the moving vehicle and the resulting dynamic wheel loads cause pavement responses which contribute to pavement distress. The pavement responses depend on the combination of dynamic wheel load, speed and local pavement strength. This relationship is compounded by the depth at which the pavement response is measured and the influence of the tyre contact patch in distributing the dynamic wheel load to the pavement structure. Over time and repeated loading by heavy vehicles, the profile changes due to vertical surface deformations which are partly influenced by the accumulation of pavement rutting. In turn these profile alterations then change the dynamic wheel loads. Also over time, the pavement structural strength changes due to the accumulated effects of pavement responses as well as environmental influences. The net effect on pavement response and distress will depend on the spatial relationship between dynamic wheel load, pavement profile change and pavement structural strength variations.

#### III.4.2 *Vehicle-bridge interaction*

Because the vehicle-bridge interaction process is governed by the physical and dynamic properties of the two components involved, a distinction needs to be made between medium- to long-span bridges, in which the vehicle as a whole can be considered as the vehicle component and short-span bridges for which the vehicle component may be reduced to a certain axle group.

##### *Medium- to long-span bridges*

True interaction occurs only if the bridge is significantly larger than the vehicle. For such interaction, the two components involved -- each modelled by a Single Degree of Freedom (SDOF) system -- join into a 2DOF system (see Figure III.2) if they exhibit the same natural frequency. The existence of interaction is easily detected because the two natural frequencies of the 2DOF systems differ from that of the SDOF system (Cantieni, 1992). Modelling of the two SDOF systems involved is relatively straightforward if the bridge fundamental natural frequency is not too close to the higher natural modes of the bridge and if the vehicle dynamic wheel loads are dominated by the body bounce mode. If the frequencies involved are practically the same, the natural frequencies of the coupled system (vehicle-bridge) depend firstly on the mass ratio, and secondly on the damping coefficients of the two systems. On the question of the mass ratio, significant system coupling has been observed in the case where the modal bridge mass was 20 times greater than the vehicle mass. This implies that vehicle-bridge interaction can

occur where the vehicle mass is as little as 5 per cent of the bridge modal mass. This is usually the case for medium- to long-span bridges.

**Figure III.1. Vehicle-pavement system**

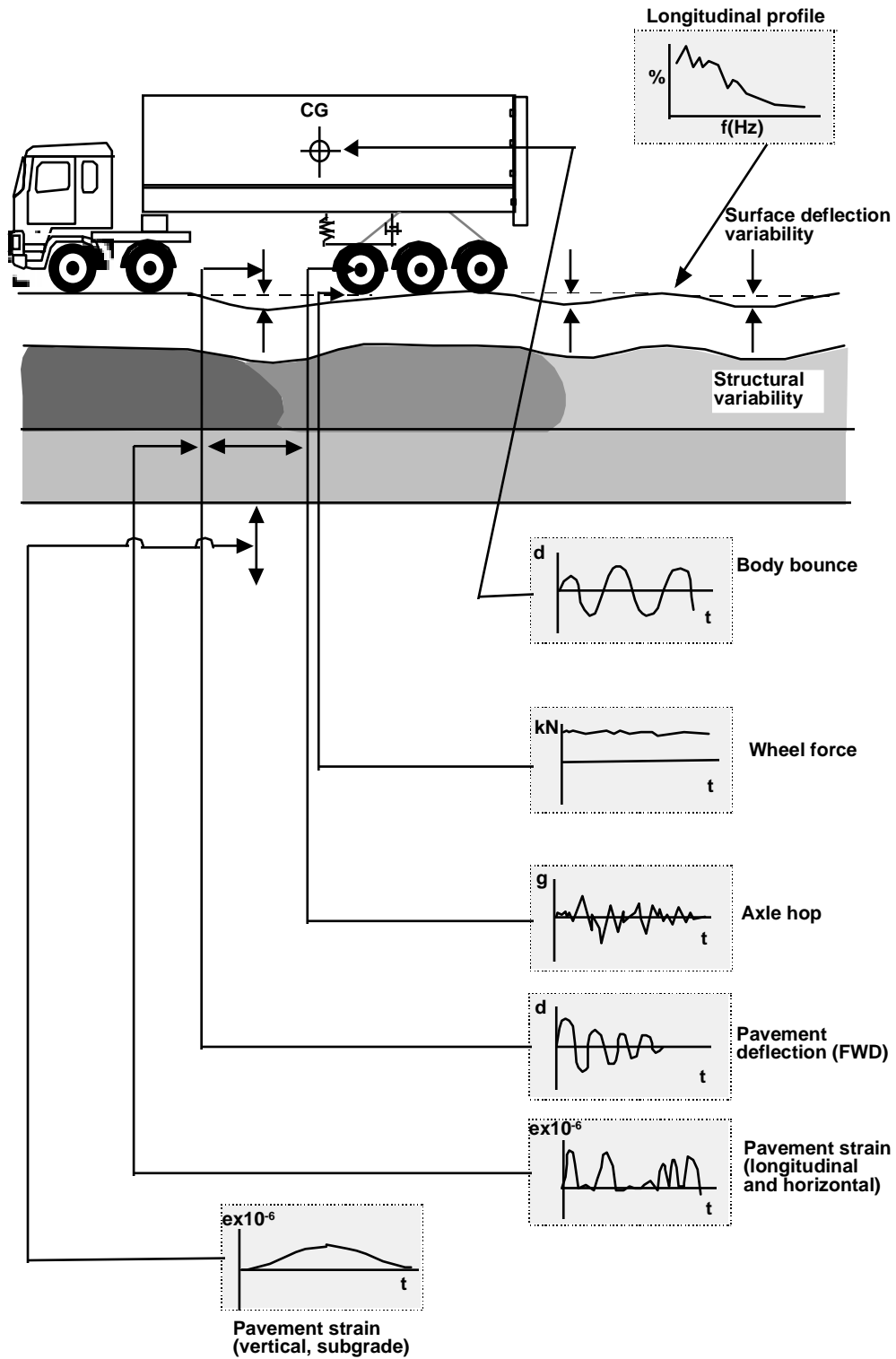

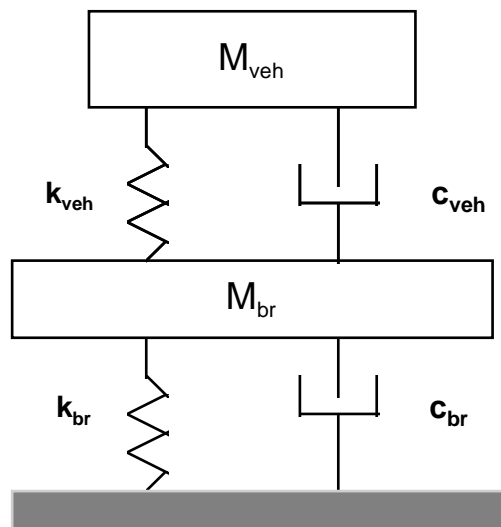
**Figure III.2. Vehicle-bridge interaction model for medium-span to long-span bridges**

In the case of the DIVINE Element 6 tests on Swiss bridges, vehicle-bridge system coupling was clearly identified in the case of the use of the NRC test vehicle with steel suspension when crossing the Deibüel Bridge (fundamental frequency  $f_1 = 3.01$  Hz). The average vehicle body bounce frequency observed while the vehicle was on the bridge was 2.7 Hz, which is smaller than the frequency of 2.8 Hz observed when the vehicle was on the approach to the bridge. System coupling was therefore experimentally proven while the vehicle was traversing the bridge.

#### *Short-span bridges*

Vehicle-bridge vibration is a very different problem in the case of short-span bridges ( $\approx 10$  m). In such cases, the length of the vehicle is usually greater than the bridge span, the bridge/vehicle mass ratio is much smaller than for medium-span to long-span bridges and the interaction involves axle hop modes on the vehicle rather than body bounce modes.

The fact that interaction occurs at axle hop frequencies changes this dynamic process completely and true interaction no longer occurs. In the case of axle hop, the vehicle body is not moving significantly relative to the bridge and the axle is vibrating between the vehicle body and the “rigid” surface of the bridge.

Under these conditions, it makes sense to change the modelling of the situation from the 2DOF “system coupling” model shown in Figure III.2 to the model of a system, namely the bridge, being forced to vibrate by external forces -- i.e. dynamic wheel loads -- without taking the vehicle masses into account. This model is illustrated in Figure III.3. In such a case, the dynamic response depends on its damping capacity only if the forcing frequency is equal to its natural frequency. This is illustrated in the Element 6 report (Cantieni and Heywood, 1998), particularly for the tests on the short-span bridges in Australia.

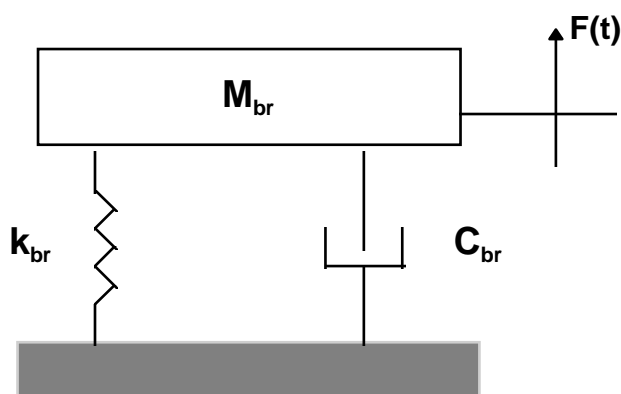
**Figure III.3. Simplified vehicle-bridge dynamic model for short-span bridges**

### III.5 The DIVINE Project and its Research Elements

The DIVINE Project involved the execution of six different Research Elements in the context of a set of overall aims and objectives, namely an improved understanding of the interaction between components of road infrastructure and the dynamic loading applied by heavy goods vehicles. The Elements of the DIVINE Project are described below in more detail. Information on the facilities and equipment used in the framework of the various Elements can be found in Annex B to this report.

#### III.5.1 Element 1: Accelerated dynamic pavement test

Element 1 comprised an accelerated test designed to cause distress and eventually failure of a road pavement under two different patterns of dynamic loading. In the test, loading patterns were applied to a single road pavement by a steel and an air suspension. Different, but known, dynamic load characteristics were therefore applied to the pavement by the two suspensions. In addition to pavement distress, the pavement structural response, profile and condition were closely monitored throughout the test (Kenis and Wang, 1997; Steven *et al.*, 1996a and 1996b).

Following a comprehensive series of Zero Measurements to establish the characteristics of both the loading and the pavement construction, the test was continued until 1.7 million load applications had been made to each pavement and a comprehensive series of measurements of the important variables in the experiment had been made.

The two system characteristics that were primarily studied were the dynamic wheel forces and the accumulation of pavement distress over time. Comprehensive measurements of each of these parameters were made throughout the test. However, because the magnitude and extent of pavement distress is related to the magnitude of the strains induced in the pavement and to the modulus, or stiffness, of the pavement materials, these subsidiary system characteristics were also measured. Due to the limitations of current measurement techniques, it is not possible to accurately or continuously measure pavement modulus in the course of an accelerated test and only inferred values from other indirect tests can be derived, for example through back-calculation of deflection bowl data. Any analyses of the effects of these subsidiary system characteristics are therefore probably less reliable than those of the more accurately measured pavement distress, whether observed as rutting or cracking of the structure.

During the test, the longitudinal pavement profile clearly influenced the dynamic wheel forces applied to the surface of the pavement. As the test proceeded, and the profile deteriorated, interaction with the loading system produced changes in the dynamic wheel forces, which in turn led to changes in the longitudinal profile. In terms of the concepts described in Section III.4 above, therefore, the accelerated pavement test examined many of the more important aspects of the vehicle-infrastructure system (Sharp and Moffatt, 1996).

### **III.5.2 Element 2: Pavement primary response testing**

The aim of this Element, which was conducted by the Federal Highway Administration (FHWA), United States (Kenis *et al.*, 1997), and the Technical Research Centre (VTT), Finland (Huhtala, *et al.*, 1997), was to measure the structural responses of several pavements to known combinations of static and dynamic loads applied at the surface by instrumented heavy vehicles. The goal was to establish how the ratio of primary pavement response to applied dynamic load changes as the frequency of the dynamic load varies. In this context, the structural response is defined as the stress or strain generated at a key point in the pavement by the passage of a dynamic wheel load. The work was carried out on heavily instrumented test roads in Finland and the United States, using the same instrumented test vehicle in each case.

The experiments were specifically designed to measure the effect of changes in the frequency and amplitude of the dynamic wheel forces brought about by gross changes in longitudinal profile. It had long been assumed that the response of viscoelastic bituminous materials may depend on the frequency content of the applied dynamic wheel loading and that pavements may not respond to high-frequency dynamic loading.

### **III.5.3 Element 3: Road simulator testing**

Element 3 was conducted by the National Research Council (NRC), Canada, in two stages (Woodrooffe, 1997). In the first stage, measurements were made of the dynamic wheel loads generated by several vehicles on several roads with different roughness profiles. These profiles were then replicated on a laboratory road simulator to check whether such tests reproduced the dynamic motion and dynamic wheel loads measured in over-the-road tests. In the second stage, the validated road simulator was used to explore ways of using such equipment to rate the road-friendliness of a vehicle suspension.

As a vehicle moves over a longitudinal pavement profile, vehicle accelerations are induced that bring about the application of dynamic wheel forces to the pavement surface. Reproducing this system in the laboratory therefore requires simulation of the longitudinal pavement profile by creating relative vertical displacements using actuators applied to the tyres of the stationary vehicle. Measurement of the resulting dynamic wheel forces is required as a check on the validity of the simulation. In Element 3, the simulation was achieved by measuring vehicle accelerations induced by the real profile and adjusting the profile in the laboratory to match these vehicle accelerations.

In the second part of Element 3, research was carried out to investigate methods for assessing the road-friendliness of vehicles. Since an important measure of road-friendliness is the extent to which dynamic wheel forces are applied by a given vehicle, the work involved the measurement of these forces under known conditions. The road simulator was used to create a range of vehicle suspension test scenarios, including the EC drop test, and to evaluate various means of characterising and measuring dynamic suspension performance in terms of road-friendliness.

#### ***III.5.4 Element 4: Computer simulation of heavy vehicle dynamics***

The empirical means for obtaining current information on the dynamic loading of road pavements, though expensive and time consuming, is a necessary first step in understanding vehicle/infrastructure interaction. Once the basic features of dynamic loading have been well established, however, and the data from empirical tests is available, the wider use of computer modelling is possible.

Element 4 (Hoogvelt and Ruijs, 1997) was therefore intended to begin this process by making use of the data from other elements and employing existing models of vehicle and road behaviour. A suitable comprehensive model requires modules that predict vehicle behaviour in given circumstances of road profile, speed and vehicle parameters -- such as suspension, dimensions, axle arrangements -- as well as other modules that predict the response of a pavement -- of any construction -- to the dynamic loads imposed.

At present, separate models of vehicle behaviour and pavement response exist in a variety of forms and have varying degrees of limitation and validation. The principal objective of Element 4, therefore, was to establish what steps could be taken now in order to develop a more comprehensive and sound computer simulation of dynamic wheel loading.

#### ***III.5.5 Element 5: Spatial repeatability of dynamic loads***

The specific objective of Element 5, which was conducted by the Laboratoire Central des Ponts et Chaussées (LCPC), France, with support from the Transport Research Laboratory (TRL), United Kingdom, was to establish the extent to which dynamic loads concentrate spatially on real roads under mixed traffic (Jacob and Dolcemascolo, 1997). Although available records of dynamic loads measured for different test vehicles operating at different speeds on different road profiles could be examined for evidence of spatial repeatability, there was nevertheless a need to demonstrate the effect in controlled conditions and to understand the influence of different parameters. More generally, the dynamic traffic loads were investigated under various vehicular and traffic conditions in order to identify the dynamic increments which are superimposed on the static loads as a result of the pavement roughness. The effect of such dynamic loads were then taken into account to estimate the increase in pavement fatigue. It remains the case, of course, that spatially repeatable loads may not act alone in influencing pavement lifetime. The approach to Element 5 was to use controlled field conditions to measure the concentration of dynamic loads under mixed traffic on a road of known profile characteristics.

A significant difference between Element 5 and other Elements of the Project, therefore, was that the study involved a wide range of vehicle types, as would be encountered in practice. Of the pavement-related system characteristics, only the longitudinal profile was measured. However, the dynamic wheel forces of a wide range of vehicle types were measured and variations (from vehicle to vehicle) of the suspension and other parameters affecting dynamic wheel forces were thereby taken into account when observing spatial repeatability.

Confirmation of spatial concentrations would imply the need to propose ways of reducing their effects perhaps through changes to vehicles or by closer attention to road profiles in construction and maintenance.

### ***III.5.6 Element 6: Bridge dynamic loads***

Bridges are clearly important components of the road network, and the nature of the vehicle-bridge interaction is very different from that of the vehicle-pavement interaction. DIVINE was interested in the possibility of the dynamic wheel forces coupling with the natural frequencies of the bridges, resulting in undesirable vibrations in bridges. The aim of Element 6, which was carried out by EMPA, Switzerland, and Queensland University of Technology, Australia, was to investigate whether road-friendly vehicle suspensions are also bridge-friendly (Cantieni and Heywood, 1998).

Medium-span bridges were investigated with respect to frequency-matching effects associated with the lower body bounce frequencies of modern soft suspensions, while short-span bridges were investigated with regard to effects in the axle hop frequency range. The objective of the research was to identify any risks to bridges associated with the introduction of modern soft suspensions. Previous work had identified groups of bridges where increased dynamic response might be expected.

In the Element 6 experiments, the vehicle-road-bridge system was investigated. The dynamic wheel forces and the primary responses (in terms of deflection) of the bridges were measured simultaneously and the road and bridge profiles were recorded using laser profilometers.

### ***III.5.7 Summary of the DIVINE Project***

The DIVINE Project was conceived as a comprehensive project, employing experimental, theoretical and analytical techniques. Many of the critical areas of the problem of vehicle-infrastructure interactions were investigated using a judicious combination of experiment and analysis.

The complementary nature of the subjects investigated in DIVINE is illustrated in Figure III.4 where the experimental and analytical work in each Element of the Project is shown with reference to each of the most important components of the system that were studied.

Figure III.4. The vehicle-infrastructure system and DIVINE

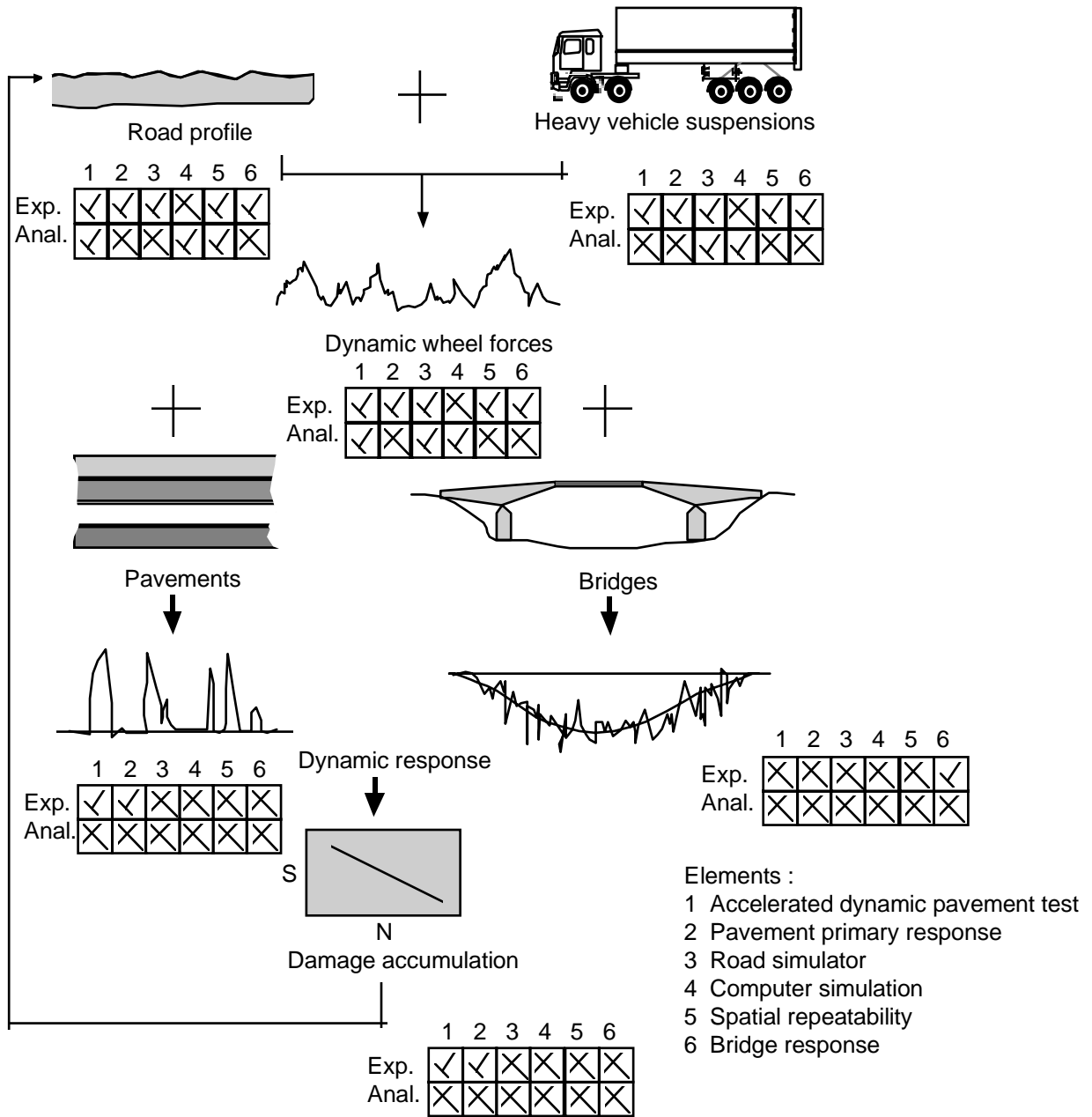

## BIBLIOGRAPHY

- BLAB, R. and B. JACOB (1997), "Test of a multiple-sensor and four portable WIM systems", Unpublished report.
- CANTIENI, R. (1992), *Dynamic Behaviour of Highway Bridges under the Passage of Heavy Vehicles*, Swiss Federal Laboratories for Materials Testing and Research (EMPA), Report No. 220, Switzerland.
- CANTIENI, R. and R. HEYWOOD (1998), *DIVINE Element 6, Bridge Research -- Report on the Tests Performed in Switzerland and Australia*, Swiss Federal Laboratories for Materials Testing and Research (EMPA), Dübendorf, Switzerland and Queensland University of Technology, Brisbane, Australia
- CEBON, D. and C. B. WINKLER (1991) "Multiple-sensor Weigh-in-motion Theory and Experiments", *Transportation Research Record 1311*, Transportation Research Board, Washington DC, United States.
- GLOVER, M.H. and W. NEWTON (1991), *Evaluation of a Multiple-sensor Weigh-in-motion System*, Research Report 307, TRL, Crowthorne, England.
- HOOGVELT, R. B. J. and P. A. J. RUIJS (1997), *DIVINE Element 4: Computer simulation of heavy vehicle dynamic wheel loads*, TNO report 97.OR.VD.016.1/RH/PR Delft, The Netherlands.
- HUHTALA, M., PIHLAJAMÄKI, J. and P. HALONEN (1997), "Pavement Response due to Dynamic Axle Loads", *Proceedings of the Eighth International Conference on Asphalt Pavements*, Volume I pp 471-485, University of Washington, Seattle.
- HUHTALA, M., PIHLAJAMÄKI, J. and P. HALONEN (1997), *Pavement Response due to Dynamic Loads*, Technical Research Centre of Finland, Espoo.
- JACOB, B. AND V. DOLCEMASCOLO (1997), *Répétabilité Spatiale des Forces d'Impact sur une Chaussée*, Laboratoire Central des Ponts et Chaussées, Paris.
- JACOB, B. and E. O'BRIEN (1996), "WAVE -- A European Research Project on Weigh-in-motion", National Traffic Data Acquisition Conference, Alliance for Transportation Research, Albuquerque.
- KENIS, W., GEORGE, D. AND J. HAMMOUDA (1997), *Pavement Primary Response to Dynamic Loading*, Report no. FHWA-RD-073, Federal Highways Administration, Washington, DC.
- KENIS, W. AND W. WANG (1997), *Analysis of Pavement Structural Variability*, Report No. FHWA-RD-072, Federal Highways Administration, Washington, DC.
- SHARP, K. G. and M. A. MOFFATT (1996), *Analysis of Performance Data Collected during Trafficking of Test Pavement by CAPTIF: Element 1 of OECD IR6 Project*, ARRB Transport Research Contract Report CR RI905/3, April.
- STEVEN, B. D., FUSSELL, A. W. and B. D. PIDWERBESKY (1996a), *DIVINE Element 1 Construction Report*, Civil Engineering Research Report 96-8, University of Canterbury, Christchurch, New Zealand.
- STEVEN, B. D., FUSSELL, A. W. and B. D. PIDWERBESKY (1996b), *DIVINE Element 1 Pavement Post-mortem Report*, Civil Engineering Research Report 96-9, University of Canterbury, Christchurch, New Zealand.
- WOODROOFFE, J. H. F. (1997), *Heavy Truck Suspensions: Methods for Evaluating Road-friendliness*, NRC & Roaduser Research, Ottawa.

## **CHAPTER IV. THE PERFORMANCE OF THE VEHICLE-INFRASTRUCTURE SYSTEM: FINDINGS OF THE DIVINE PROJECT**

The research carried out under the six Elements of the DIVINE Project provided a series of “cross-sectional” views of the nature of the interaction between the infrastructure and heavy vehicles. While an effort was made to maintain common threads of road and vehicle characteristics through the various research Elements, there is a definite limit to the ability of the DIVINE Project to provide a comprehensive and globally applicable picture of vehicle-infrastructure interaction.

Most of the Elements were concerned with the measurement or simulation of the responses of particular components of the vehicle-infrastructure system, and the DIVINE Project provides the greatest breadth of information at this level. Only Element 1 attempted to measure infrastructure wear, or “damage”, and this was limited to a single accelerated dynamic pavement testing experiment.

The implementation of the DIVINE research results will require actions specific to each of the main operational sectors involved -- i.e. pavement managers, bridge managers and the road transport industry. The findings of DIVINE are therefore presented in the following three sections:

- The response of the infrastructure (both pavements and bridges) to heavy vehicles. Research findings are drawn from the results of Element 2 (primary response of pavements), Element 5 (influence on spatial repeatability of dynamic loading) and Element 6 (primary response of bridges).
- The effects of heavy vehicle suspensions on pavement condition and performance. Research findings are drawn from the results of Element 1 (accelerated dynamic pavement test).
- The assessment of heavy vehicles for “road-friendliness”. Research results are drawn from Element 3 (vehicle assessment) and Element 4 (computer simulation of heavy vehicles).

As shown above, each Research Element falls into one or another of the operational sectors. Because of these relationships, the following sections do not present the Elements sequentially, but rather according to the operational sector to which they belong. The complete results of each Research Element are presented in a separate series of research reports and Section III.5 of this report contains summary descriptions of each Research Element.

### **IV.1 Infrastructure response to vehicles**

The application of a load to a flexible pavement comprising, generally, non-linear and viscoelastic materials sets up a system of stresses, strains, and transient and permanent deflections in the pavement. This system is frequently referred to as the response of the pavement to the load. For many years, pavement design has been concerned with the changes in the system as the magnitude and

frequency of the applied load changes because response parameters influence the nature and rate of deterioration of the pavement as traffic uses it. A knowledge of pavement response therefore provides not only guidance on the design criteria for the pavement structure, but can also be an important indicator of pavement condition. The constitutive equations describing the response of the pavement to load are complex and much effort has been devoted to their refinement and validation for use in pavement performance and response models.

It is well known that as a truck moves along a pavement its load is not steady but can vary between 10 and 40 per cent above or below the static load, depending on the type of suspension, static axle load, speed of travel and longitudinal profile of the pavement. Most vehicles generate dynamic wheel loads because of dominant vehicle bouncing and pitching motions in the 1.5 - 4 Hz frequency range, but some poorly damped axle group suspensions also generate dominant loads at frequencies of 8 - 16 Hz due to axle bounce motion. Although the DIVINE Project has considerably advanced our understanding, very little is known about the effects of dynamic loads on pavements. However, the European Union, for example, allows a higher axle load (e.g. 115 kN rather than 100 kN) in some cases if an air suspension or some other form of "road-friendly" suspension is used, although this decision is based on engineering judgement rather than on any comprehensive research.

Most pavement response models calculate the response of the pavement to a static or quasi-static load and do not allow for the complete modelling of the in-service condition, namely the dynamic loading of the pavement. The development and improvement of such models must be based on a knowledge of whether or not the flexible pavement will respond to the dynamic loads it is likely to encounter in practice. Improvements to techniques for the simultaneous measurement of strains and deflections in pavements as well as the load applied by a test vehicle have provided the tools for measuring actual pavement and vehicle responses. The DIVINE Project took advantage of these techniques to provide useful information on this topic.

The purpose of Element 2 of the DIVINE Project was, therefore, to determine, under controlled test conditions, if the ratio of dynamic load on the pavement to the strain measured within the pavement varied as the frequency and magnitude of the dynamic load varied. In order to achieve this, it was necessary to simultaneously measure, and then compare, the vehicle's dynamic wheel forces and the strains within the pavement. If the strains could be shown to be dependent on dynamically varying loads, then the benefits of road-friendly suspensions, in terms of reducing damage to the pavement, could be demonstrated.

Spatial repeatability is the tendency for a vehicle, or a set of vehicles, to impose the same load patterns during different passes on the same stretch of pavement. Of particular interest is the potential for dynamic loads to concentrate at, or near, particular points on the road surface. If spatial repeatability is significant, then the response of the pavement to that concentration of loads will clearly influence the deterioration of the pavement in that area. Furthermore, if the concentrations of loading are linked to recognisable features of the longitudinal profile of the pavement, then the pavement engineer may be able to take corrective action to prevent localised damage.

The aim of Element 5 of the DIVINE Project, therefore, was to study spatial repeatability and to identify its sensitivity to a range of parameters.

Bridge responses to dynamic loading were studied in Element 6 of the DIVINE Project.

#### ***IV.1.1 Pavement primary response and dynamic loading -- Details of Element 2 research***

The work conducted under Element 2 involved three instrumented flexible pavements, one a test road located at the FHWA (United States) (Kenis *et al.*, 1997), the others being the VTT (Finland) test sites (Huhtala *et al.*, 1997). The thickness of the bituminous pavement tested by the FHWA was 150 mm (6 inches), whilst two bituminous pavements were tested by the VTT: a “thick” pavement of 150 mm and a “thin” pavement of 80 mm. All pavements were instrumented with closely spaced strain gauges placed at both the top and the bottom of the bituminous layer and positioned along the line of a test vehicle’s passage along the pavement’s surface. This enabled the strains generated in the pavement to be measured simultaneously with the applied dynamic loads.

The FHWA pavement was trafficked by the NRC 5-axle articulated vehicle, whilst the VTT pavements were tested by the 2-axle rigid VTT vehicle, the 2-axle TRL vehicle and the NRC vehicle. In order to measure the dynamic wheel forces applied to the pavement, all test vehicles had at least one axle instrumented with strain gauges and accelerometers. The lateral and longitudinal location of the tyres with respect to the gauges was also recorded as the vehicles passed over them. Most of the testing was conducted at 45 km/h in order to duplicate the nominal speed of the CAPTIF accelerated pavement testing facility used in Element 1. However, tests were also conducted by the FHWA at creep speed and at 15, 25 and 35 km/h, and some tests were carried out by VTT at 10, 30, 50 and 70 km/h.

To take account of the fact that dynamic loading is the combined result of both body bounce (frequencies between 1.5 and 4 Hz) and axle hop (frequencies between 8 and 16 Hz), it was deemed desirable to relate both forms of loading to pavement response. Two different bumps were used in the experiments: a long plywood bump, 4 m long and 50 mm high, designed to generate vehicle body bounce, and a short steel bump, 0.3 m long and 25 mm high, designed to generate axle hop. The FHWA testing was conducted using the long bump only, whilst VTT conducted testing with both bumps. In both cases, testing was also conducted without bumps on the pavements.

Both experiments were successful in that it was possible to simultaneously, and accurately, measure the dynamic loads and the pavement response and to generate both high frequency (axle hop) and low frequency (body bounce) modes through the use of the bumps. However, accurate calibration of the sensors for pavement response measurements was found to be essential. In order to capture dynamic pavement responses to a moving load, all sensors in the array must be calibrated to have the same reading when the same load is applied in order to account for the variability between sensors due to, for example, gauge construction and placement, pavement layer thickness or material variability. These variability calibrations were undertaken at both sites using a moving load. Temperature calibrations were made in order to normalise all measurements to a standard temperature because strain gauges of the type used in the experiments are sensitive to changes of as little as 1°C.

The results of the studies showed that the horizontal longitudinal strains measured at both the top and bottom of the 150 mm bituminous layers were directly proportional to the instantaneous applied load, irrespective of the type of suspension tested (Figures IV.1 to IV.7), and increased linearly with the measured dynamic axle loads.

Because a flexible pavement system is viscoelastic, its response will be increased for slowly moving loads. Although the FHWA pavement responded in a linear elastic way at the higher test speeds, viscoelastic behaviour brought about a large increase in mean pavement strain at low or creep speed. For normal road roughness conditions, the average unit strain at the surface of the pavement increased by between 50 and 70 per cent, and at the bottom of the base course by between 40 and 55 per cent when vehicle speed was reduced from the higher test speeds (25 - 45 km/h) to creep speeds.

Without the use of the bump, maximum load for the fourth axle was 7.9 per cent greater than mean load, while maximum surface strain was 12 per cent greater than mean surface strain. Using the bump, maximum load was 32.6 per cent greater than mean load, while maximum surface strain was 32.9 per cent greater than the mean top strain.

**Figure IV.1. Tyre forces and pavement strain vs. distance, 45 km/h, 5.45 tonne load, no bump**

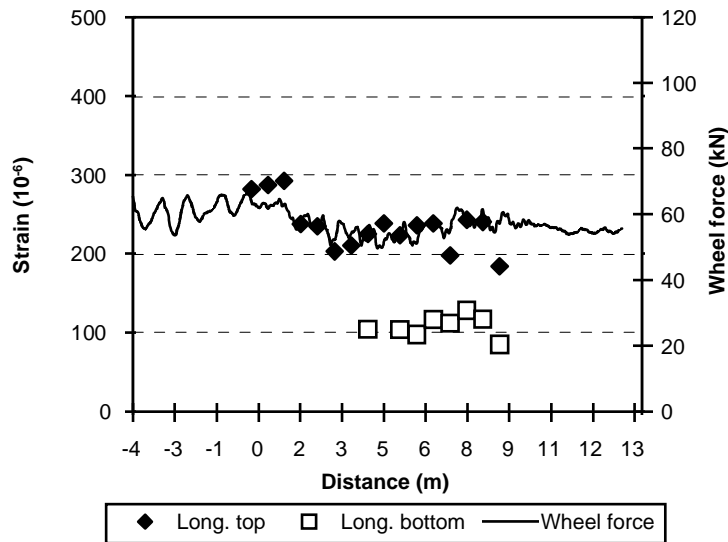

Source: Kenis et al., 1997

**Figure IV.2. Tyre forces and pavement strain vs. distance, 45 km/h, 5.45 tonne load, with bump**

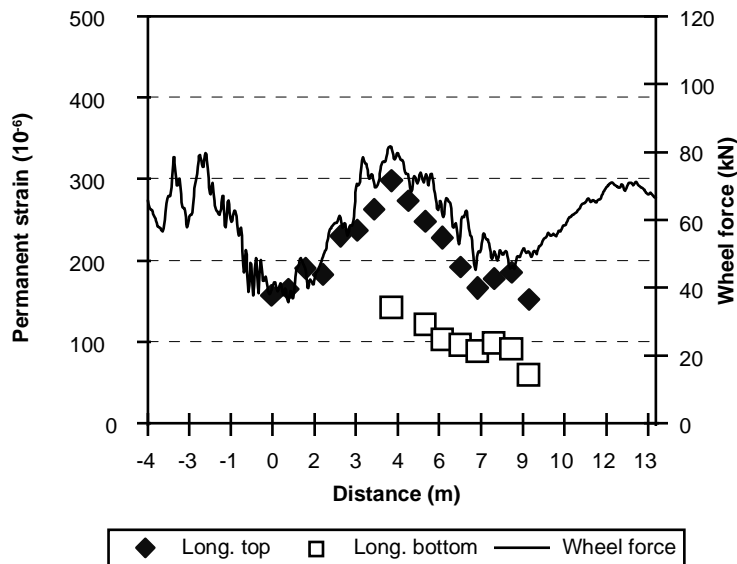

Source: Kenis et al., 1997

**Figure IV.3. Dynamic wheel loads (597, 587) and corresponding strains in pavement (S597, S587), short bump, Canadian vehicle**

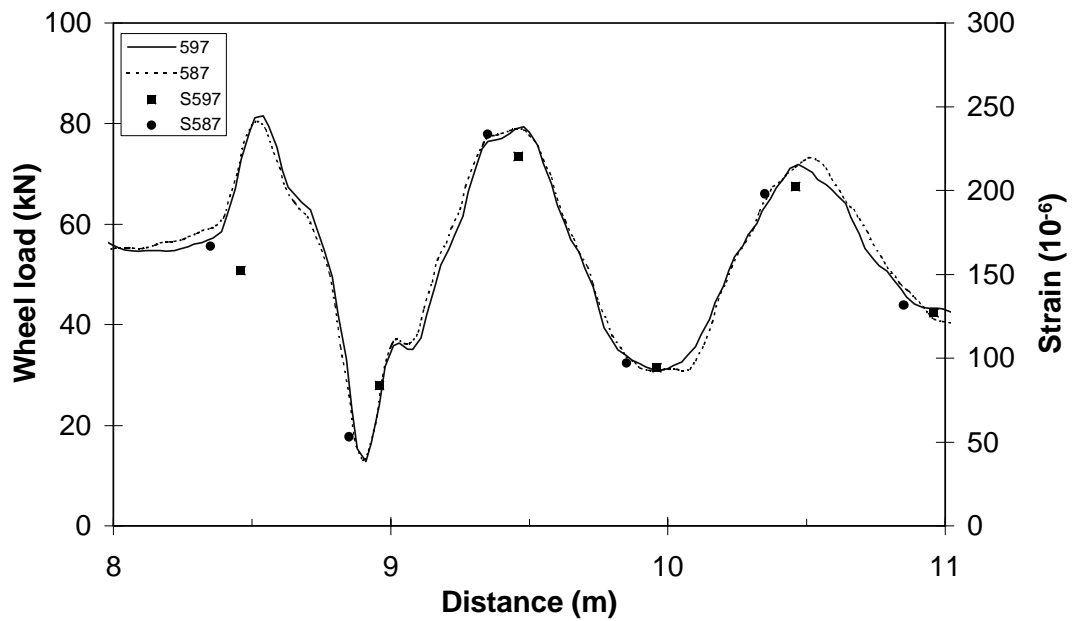

Source: Huhtala *et al.*, 1997

**Figure IV.4. Strains as a function of wheel load, thick pavement, long bump, Canadian (NRC) and United Kingdom (TRL) vehicles**

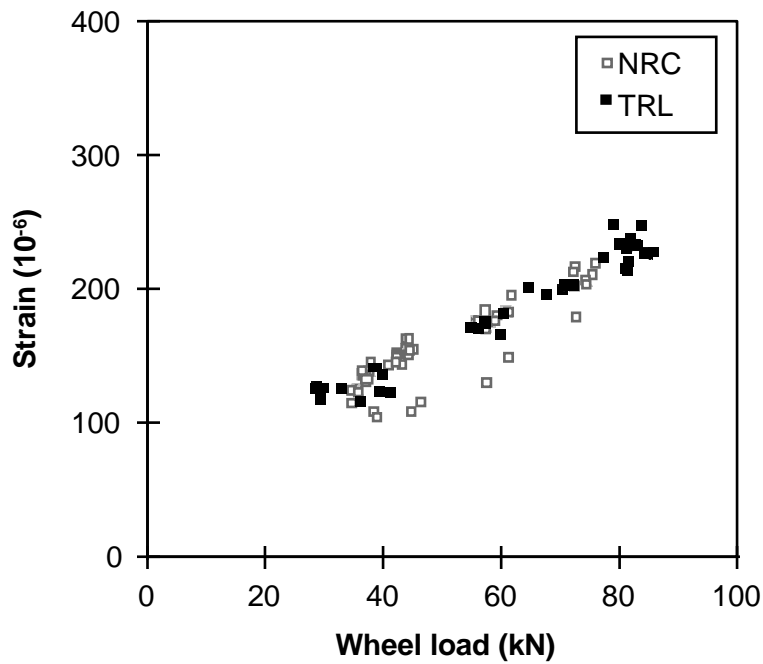

Source: Huhtala *et al.*, 1997

Figure IV.5. Strains as a function of wheel load, thick pavement, short bump

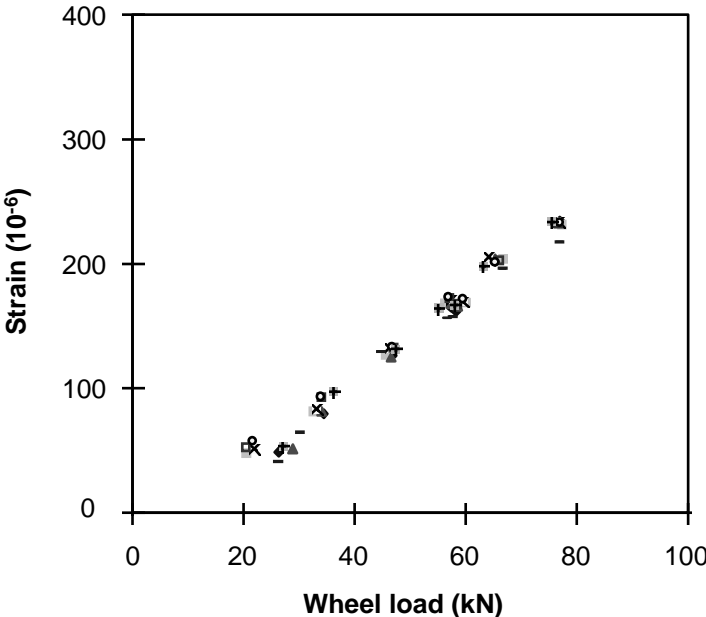

Note: Each type of mark corresponds to one vehicle pass (Canadian vehicle)

Source: Huhtala et al., 1997

Figure IV.6. Strains as a function of wheel load, thin pavement, long bump

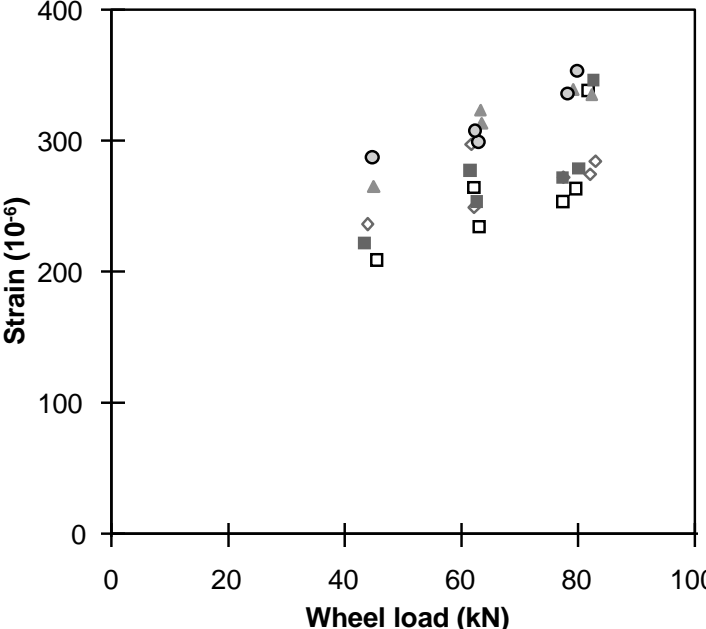

Note: Each type of mark corresponds to one vehicle pass (Canadian vehicle)

Source: Huhtala et al., 1997

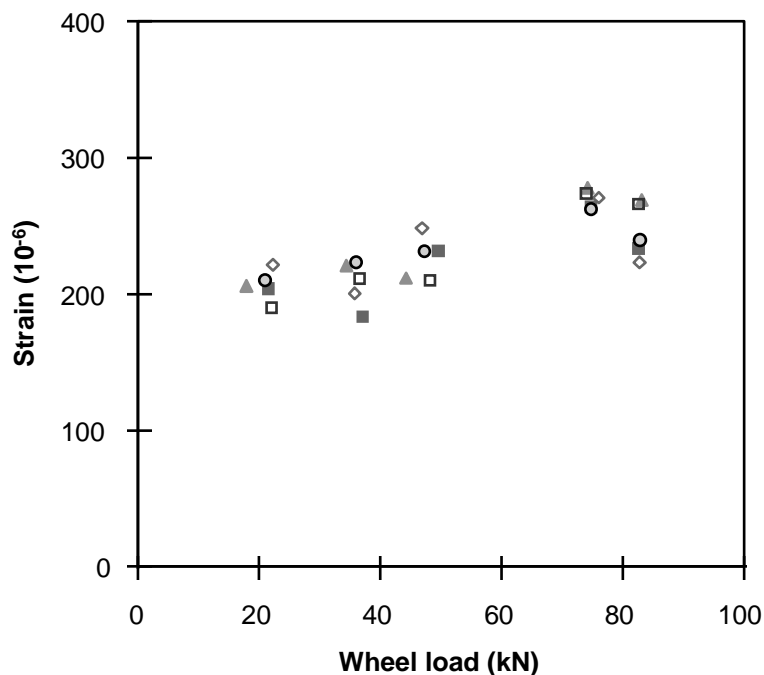
**Figure IV.7. Strains as a function of wheel load, thin pavement, short bump**

*Note:* Each type of mark corresponds to one vehicle pass (Canadian vehicle)

*Source:* Huhtala *et al.*, 1997

In the case of the thin pavement tested by VTT, the results were less clear. The measurements of strain at the underside of the base of the pavement, as a function of applied load, were more dispersed and the direct proportionality was less evident. This may have been due to the fact that, for the thinner pavement, the measured strain was more sensitive to the transverse position of the loaded wheel as it passed over the gauge, but other factors may have been equally important. These include the possibility that non-uniform contact stresses at the tyre-road interface are more influential on strains in thin pavements and that the interaction between the applied load and the shape of the strain pulse is greater on thinner pavements.

Because only two thicknesses of pavement were tested at VTT, it was not possible to determine the thickness of pavement at which the nature of the proportional relationship (between strain and applied load) changed. The relationship is probably also affected by the moduli of the bituminous surface layer and the granular base layers.

The VTT noted, however, that for thin pavements the axle hop frequency interacted with the strain pulse at the test speed of 45 km/h to produce an amplification of the strain. This suggests that these results need to be interpreted carefully.

In summary, the results indicated that, for pavements of about 150 mm bituminous thickness, there was a direct and proportional relationship between primary pavement response and the instantaneously applied load. This implies that these types of pavements in service will experience peak strain levels at the underside of the bituminous material that directly reflect the degree of dynamic loading applied to them. For the thinner test pavement, the relationship is much less clear, and a number of other

factors affecting the tyre-pavement interface and the load-spreading may be responsible for this. Such pavements will, in service, experience a wider range of peak strains for a given applied dynamic load. The effect of decreasing vehicle speed, particularly on thick pavements, is to increase the peak strain level experienced at the surface of the pavement substantially more than at the underside of the bituminous layer.

#### ***IV.1.2 Pavement dynamic loading and spatial repeatability -- Details of Element 5 research***

##### *Test sites*

As part of the DIVINE Project, an experiment was carried out on a relatively smooth (IRI of 1.73 m/km) major road in good structural condition. The road, at a site near Trappes, France, had two traffic lanes in each direction with 3 500 trucks/day on the slow, instrumented traffic lane (Jacob and Dolcemascolo, 1997). An array of 24 piezo-ceramic WIM sensors that covered a 36 m length of road was used to measure the variations of the dynamic axle loads and to detect maxima and minima in the loading applied by trucks.

Some measurements made by the TRL in 1992/93 on Motorway A34, at Abingdon (United Kingdom), were also considered. The pavement conditions were rather poor with an uneven surface (unknown IRI value), rutting and some cracking. An array of 48 uniformly spaced half-capacitive strip sensors (24 lines) was used. Because of some sensor problems, many of the measurements have been considered to be unreliable and only a few results are reported here.

##### *Instrumentation of the test site in France (Trappes, RN10)*

The design of the multi-sensor array was based on prior experience and on theoretical considerations in regard to signal processing and sampling. The purpose was to achieve the fullest possible analysis of impact force signals at different wavelengths or frequencies. Frequencies in the range of 1.5 - 2.5 Hz (body movements, wheel bounce, yaw, pitch and roll), 3.5 - 5 Hz (vibration of suspensions, first harmonic of body vibrations) and 10 - 15 Hz (vibrations of unsprung masses) were considered.

The speeds on this site were between minimum velocity ( $V_{min}$ ) of 14 m/s (50 km/h) and a maximum velocity ( $V_{max}$ ) of 25 m/s (90 km/h). For each of the three frequency ranges, the minimum length ( $L$ ) of the array and maximum sensor spacings ( $d$ ) were in the order of the following:  $L = 2.5$  m, 7.1 m and 16.7 m; and  $d = 0.375$  m, 1.12 m and 2.25 m. Initially 18 sensors were installed covering a length of 22.5 m, and a year later six sensors were added to better analyse the long wavelengths. The 24 sensor array was designed as follows:

- seven sensors at a spacing ( $d_1$ ) of 0.375 m,
- four sensors at a spacing ( $d_2$ ) of 1.125 m ( $d_2 = 3d_1$ )
- 13 sensors at a spacing ( $d_3$ ) of 2.25 m ( $d_3 = 2d_2 = 6d_1$ )

By considering some sensors separately -- i.e. outside of their primary array -- the layout created the three following sub-arrays of uniformly spaced sensors:

- seven sensors at a spacing ( $d_1$ ) of 0.375 m;
- seven sensors at a spacing ( $d_2$ ) of 1.125 m;
- 17 sensors at a spacing ( $d_3$ ) of 2.25 m.

#### *Pavement profile of the RN10*

The profile along the road section that included the WIM array was measured using an APL 72. This quantifies the wavelength in 200 m sections and produces three ratings in three wavelength bands. Measurements are carried out at 20 m/s (72 km/h). Two trailers follow longitudinal paths which correspond to the two wheel tracks of a light vehicle. The conventionally accepted wavelengths for roughness measurement are between 0.5 m and 50 m, with amplitudes of between a few tenths of a millimetre for the smallest detected wavelengths and several tens of millimetres for long wavelengths.

Measurements were carried out in November 1993 and again in December 1995. The results of these measurements were identical. The APL rating is given for three wavelength ranges as follow:

- short wave = 8 (very good);
- medium wave = 7 (good);
- long wave = 6 (moderate).

In general, these values correspond to a good level of evenness for a French trunk road. The 200 m section which included the array of piezo-ceramic bars had an IRI rating of 1.73 m/km and, therefore, generally qualifies as a good quality pavement.

#### *Measurements carried out with trucks from the traffic flow on the RN10*

Initially, vehicles of known static weight and axle configuration (test vehicles) made repeated runs at various speeds. Subsequently, similar measurements were made, both for some pre-weighed vehicles and for all vehicles, of the stream of heavy vehicles on the road. Static axle loads, gross weight and suspension type were noted for the pre-weighed trucks, while the configuration of all the measured vehicles of the traffic flow were recorded. For unweighed traffic, the static axle loads and gross weight were estimated by averaging the impact forces measured by 13 uniformly spaced sensors. It was shown that the accuracy of this estimation meets the requirement of the class B+(7) of the European Specification on WIM (Cost 323, 1997) -- i.e. approximately 90 to 95 per cent of the measured loads are within  $\pm 7$  per cent (gross weight),  $\pm 10$  per cent (group of axles),  $\pm 11$  per cent (single axle) and  $\pm 14$  per cent (single axle within a group) with respect to the static loads.

Between June 1994 and May 1995, 76 pre-weighed trucks, including eleven repeated runs using a two axle rigid truck (deflectometer), were measured over six days. During the week of 3-9 April 1995, 2 976 trucks (over 6 tons) in the traffic flow were also recorded. Table IV.1 shows the composition of these samples and confirms that the pre-weighed truck sample is representative of the whole traffic flow. Between 80 and 90 per cent of the speeds were between 70 to 90 km/h.

**Table IV.1. Comparison of the samples of pre-weighed and traffic flow trucks**

Population	Cumulative duration	Sample size N	Mean speed (km/h)	Percentage of 2 and 3 axle rigid trucks (types 1-2)	Percentage of semi-trailers (types 4-5) <sup>1</sup>
Pre-weighed	6 days	65 + 11	73.4	21	74
Traffic flow	7 days	2 976	79.1	20	67

1. type 4 = 2 axle tractor with a semi trailer equipped with a tandem  
 type 5 = 2 axle tractor with a semi trailer equipped with a tridem

Source: LCPC

### Impact factors

The impact factor for each axle on each sensor was calculated as the ratio between the measured impact force divided by the static axle load. Likewise the impact factor was calculated for each vehicle on each sensor as the sum of measured axle impact forces divided by the static gross vehicle weight. The results were carefully analysed to establish the amplitude of the impact factor *vs.* speed, suspension type, truck configuration and other criteria. The results were also used to determine whether or not statistical spatial repeatability was indicated. Figure IV.8 shows that “road-friendly” air suspensions only reduce the maximum impact factors for the rear tandem and tridem axles of the articulated semi-trailer trucks (from 1.25 to 1.15), but have no significant effect for the axles of the tractors or rigid trucks. Of the trucks analysed in the sample, air suspension was present for 30 per cent of the axles in positions 1 and 2 and for 60 per cent of the axles in positions 3 to 5.

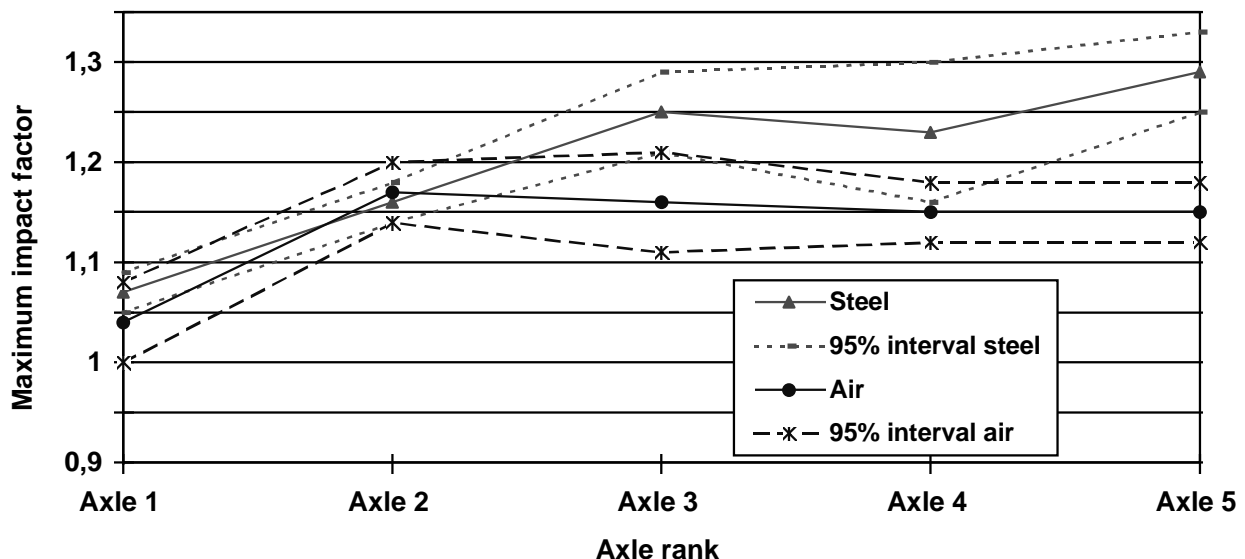
**Figure IV.8. Maximum impact factor *vs.* axle position and suspension type**

Note: Axles 1 and 2 are either those of 2 axle rigid trucks or belong to the tractor of articulated trucks; axles 3 to 5 are those of the tandem or tridem of the semi-trailers.

Source: LCPC

*Spatial repeatability*

Spatial repeatability was assessed by analysing the variations of the impact factors along the pavement, and especially the tendency for the maxima and minima to be repeated at the same point. However, this phenomenon is highly dependent on traffic and pavement conditions. For a single vehicle, under a single set of conditions (load and speed), spatial repeatability of the loading pattern takes place over a number of runs, even on a smooth pavement, as shown with the two axle rigid truck (deflectometer) in Trappes (Figure IV.9). For each speed range (45 and 60 km/h), the spatial repeatability was assessed. The wavelengths of the impact factors were almost proportional to the speed, implying that the vehicle eigenfrequency was dominant. Thus, the spatial repeatability was reduced for mixed speeds. It was also noted that spatial repeatability was more significant as the axle load increased.

**Figure IV.9. Impact factors for axle 2 of deflectometer**

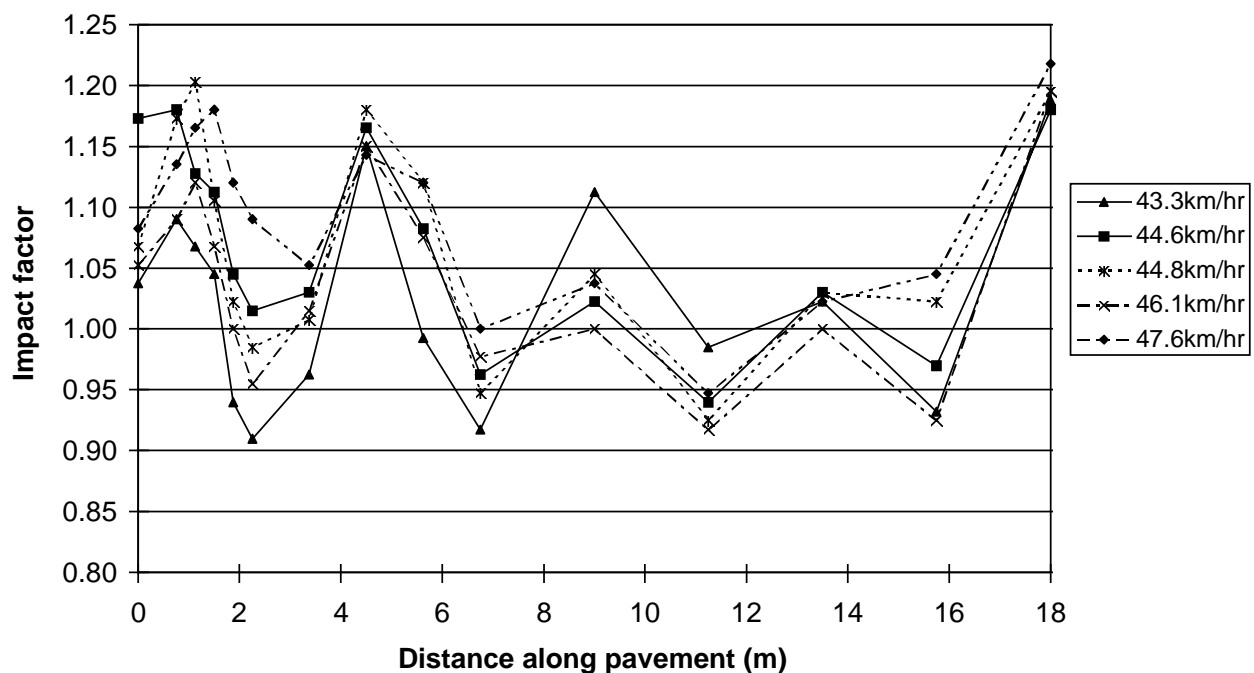

Source: Jacob and Dolcemascolo, 1997

If vehicles in the traffic stream are considered individually -- i.e. all of those with the same configuration but each with a different speed, load, suspension and dynamic characteristics -- spatial repeatability is not observed due to the random variation of speed and dynamic loads in the sample. An example is given in Figure IV.10 for the gross weights of articulated 5 axle (type 5) trucks.

If, on the other hand, the impact factors of a set of vehicles are averaged, the mean being taken over several paths -- i.e. for each point along the pavement -- it was found that for a small (5 to 10) sample of a given type of vehicle, spatial repeatability is observed, but much less than for repeated runs of the same vehicle under the same conditions. Figure IV.11 gives the results for the gross weights of a type 5 vehicle where each sample contains between 4 and 12 trucks.

However, when the sample becomes larger (40 to a few hundred vehicles), there was evidence of spatial repeatability for a given configuration of vehicle (Figure IV.12) as well as for all types of trucks

(Figure IV.13). This was attributed to the fact that, in the larger sample, the effects of random variation of speed and dynamic loading were minimised by the averaging. This phenomenon is called “statistical spatial repeatability”.

**Figure IV.10. Individual impact factors for gross vehicle (type 5) weights**

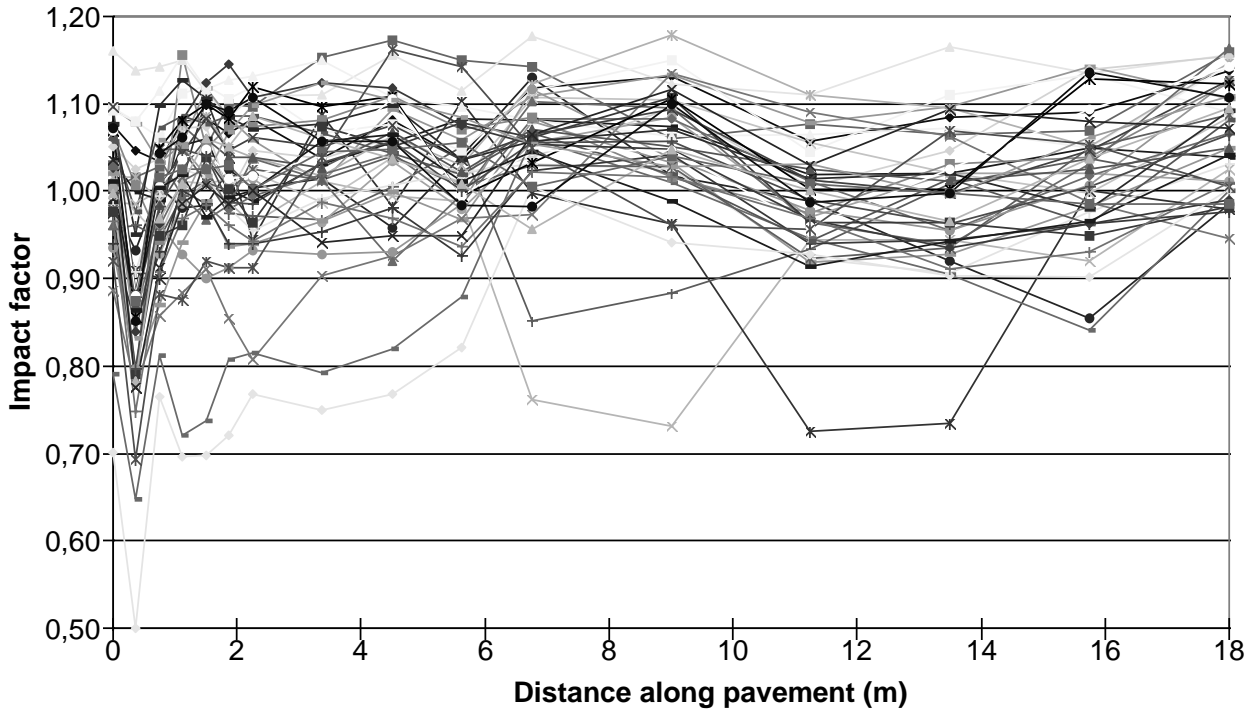

Source: Jacob and Dolcemascolo, 1997

**Figure IV.11. Mean impact factors for gross vehicle (type 5) weights -- small sample**

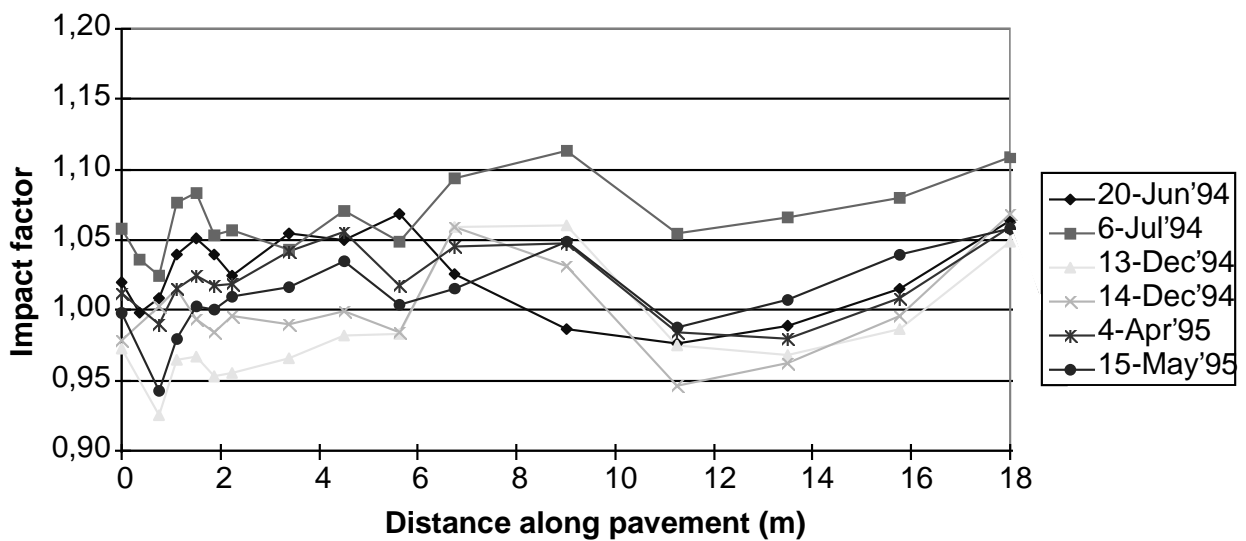

Source: Jacob and Dolcemascolo, 1997

**Figure IV.12. Mean impact factors for gross vehicle (type 5) weights -- large sample**

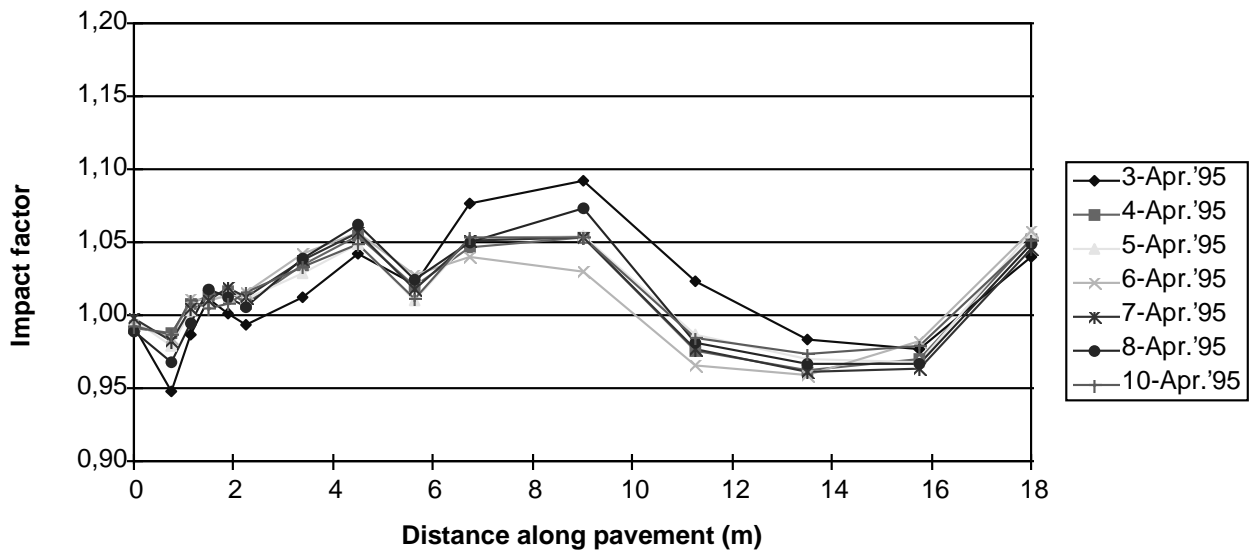

Source: Jacob and Dolcemascolo, 1997

**Figure IV.13. Mean impact factors for gross vehicle (types 1-9) weights**

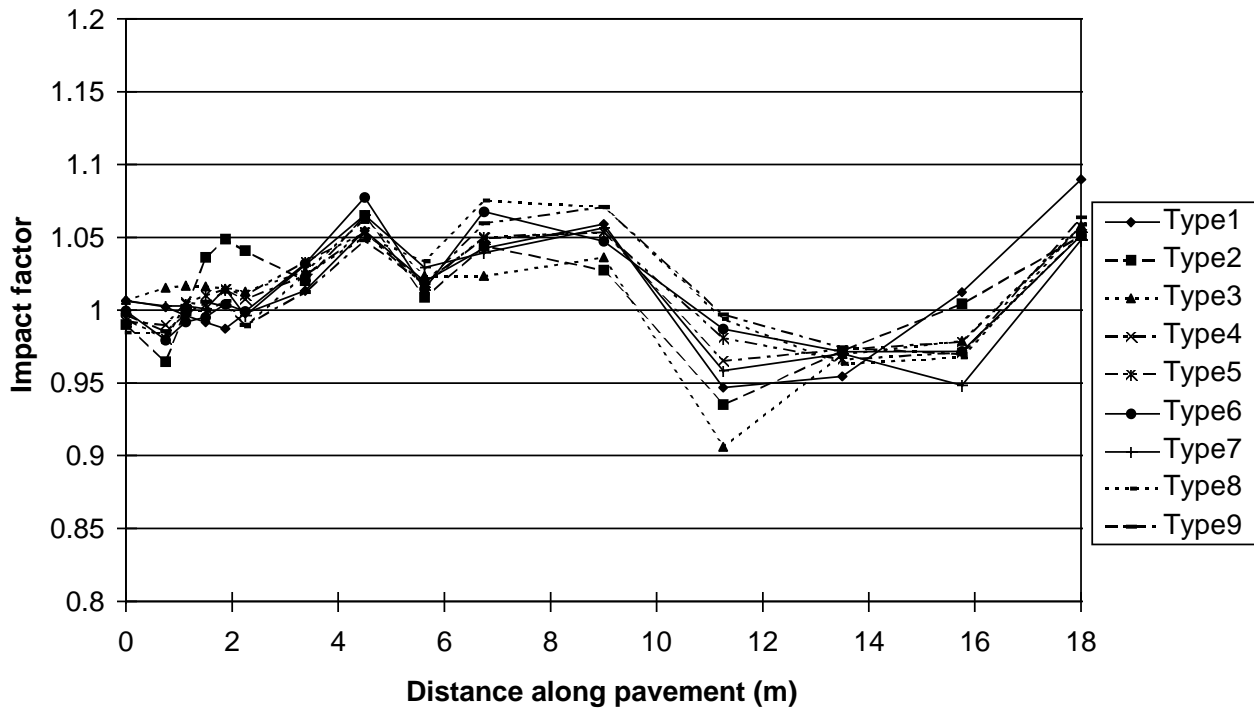

Source: Jacob and Dolcemascolo, 1997

The measurements made on the A34 in Abingdon, United Kingdom (Figure IV.14), show an increase in the mean impact factors in line with the higher roughness of the pavement. The mean impact

factors are in the range of 0.87 to 1.22 instead of 0.90 to 1.10 found on the RN10. With such a rough pavement, the spatial repeatability also becomes much higher.

**Figure IV.14. Mean impact factors for gross vehicle weights, Abingdon, A34, near-side track**

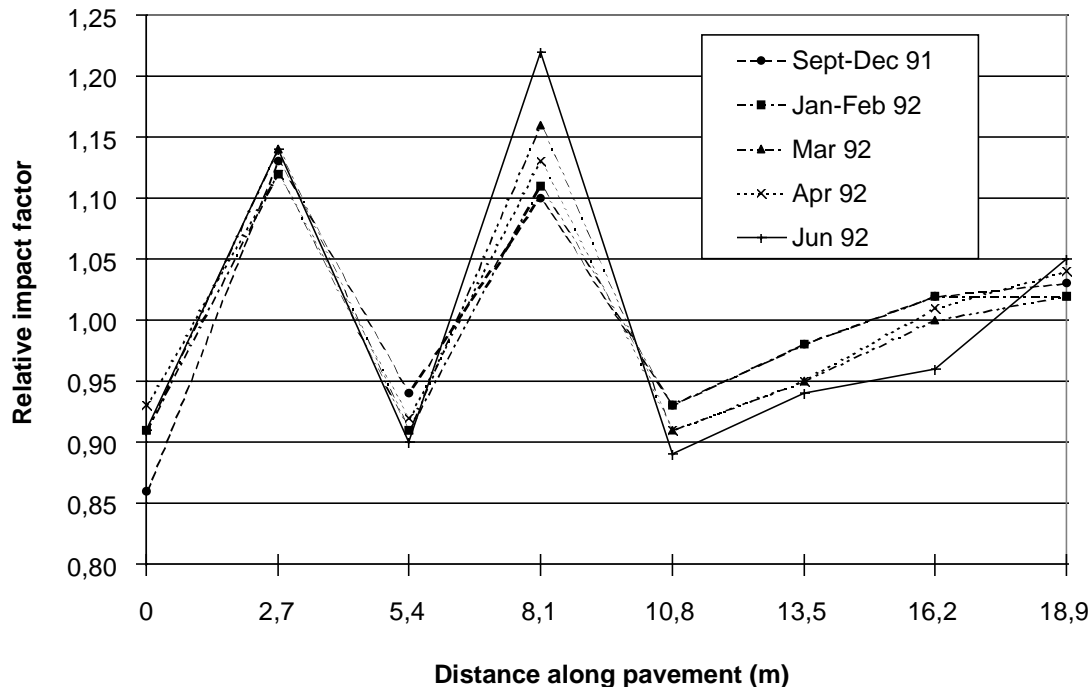

Source: TRL

#### *Pavement wear*

The implications of the Element 5 findings for pavement design and maintenance are discussed in the following chapter. However, using conventional pavement wear and fatigue relationships, the results described above suggest that dynamic loading introduces a 30 to 50 per cent increase in damage as compared with that for static loading. Extending this result to the case of a rough road shows that the figure would be substantially higher. Because the deterioration and failure modes of rigid pavements are different from those of flexible pavements, the effect of statistical spatial repeatability on such roads can only be considered theoretically. On this basis, an increase of as much as 200 per cent may be apparent on some sections of relatively smooth concrete road.

By considering the different effects of the same vehicle type equipped with either air or steel suspension, the work also concluded that the use of an air suspension, particularly on that class of vehicle responsible for the greater part of pavement damage (often the 5-axle semi-trailer), could reduce dynamic loads by 10 to 12 per cent and therefore lead to significantly reduced pavement damage.

#### *Spectral analysis and vehicle dynamics*

An extensive analysis of the wheel and axle impact force variations in the frequency and wavelength domain was performed using spectral analysis. The Power Spectral Density (PSD) was computed for the instrumented NRC truck (with air suspension) and German trailer (with both air and

steel suspensions) at several speeds and loads. At low speed (30 km/h), the wheel impact force variations are governed by the wheel imbalance which leads to a peak centred at 2.6 Hz in the frequency domain (i.e. a wavelength of 3.2 m, which is the wheel perimeter -- see Figure IV.15). With a constant wavelength, this peak frequency varies proportionately to the speed. It is still visible at 80 km/h (6.93 Hz as shown in Figure IV.16). This effect becomes even more important with the German trailer. The first two or three harmonics of this vibration are also significant, particularly if resonance occurs with vehicle eigenfrequencies. At high speed (80 km/h), the main variations of the axle impact force are a result of the truck bounce mode for air suspension (approximately 1.6 Hz) and the axle hop mode (approximately 11.5 Hz), as shown in Figure IV.16.

**Figure IV.15. PSD of the wheel impact force, NRC instrumented vehicle, 30 km/h, GW = 359 kN**

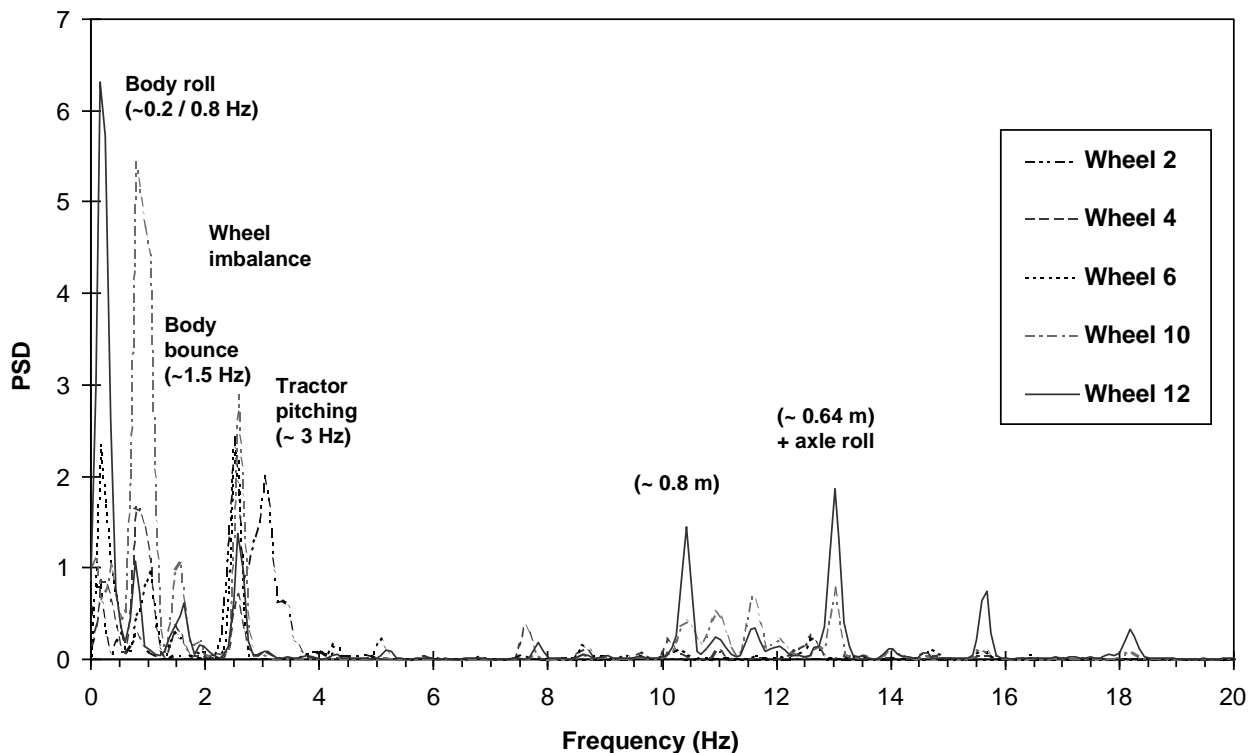

Source: NRC

These vehicle-related effects are somewhat sensitive to the suspension type because of their frequency characteristics. However, they are not in phase with the pavement profile and therefore do not increase the spatial repeatability. Nevertheless, some attention must be paid to the risk of resonance between the pavement profile medium wavelengths and the wheel perimeter or between medium/short wavelengths of the pavement profile and the vehicle/axle eigenfrequencies at speeds higher than a creep, both of which could significantly increase the impact factors.

IV.1.3 Bridge response -- Details of Element 6 research

Maximum measured dynamic increments

The dynamic increment  $\phi$  compares the maximum dynamic bridge deflection  $A_{dyn}$  and the maximum static deflection  $A_{stat}$ . The definition of the dynamic increment  $\phi$  shown in Figure IV.17 is used throughout this report.

Figure IV.16. PSD of the wheel impact force, NRC instrumented vehicle, 80 km/h, GW = 359 kN

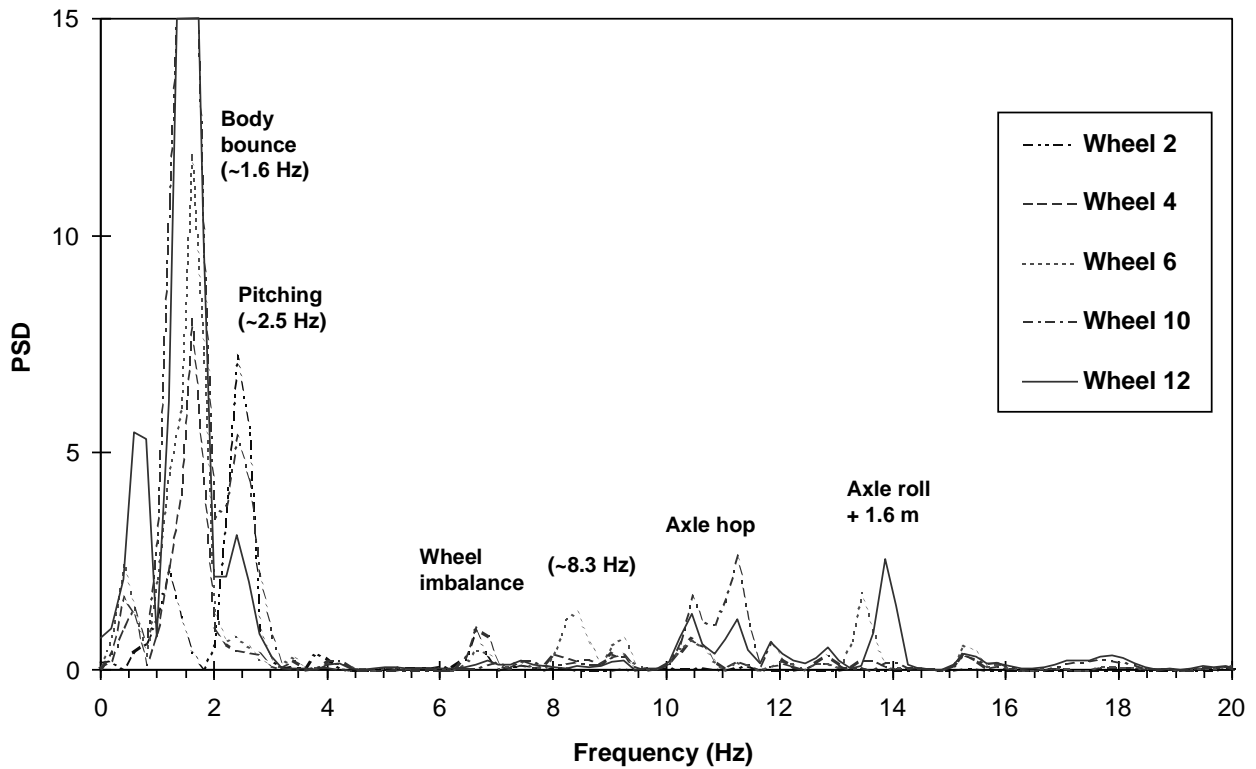

Source: NRC

Figure IV.17. Time history with the definitions of the dynamic increment  $\phi$  (per cent), the fundamental frequency  $f$  (Hz) and associated damping decrement  $\delta$  (or, damping coefficient  $\zeta$  as a percentage of critical:  $\zeta = \delta/(2\pi)$ )

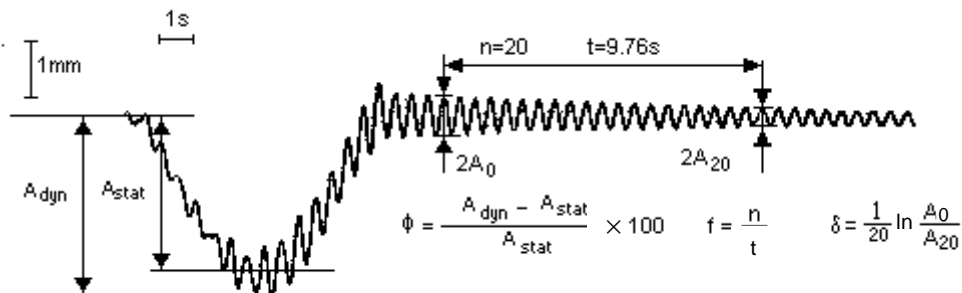

Source: Cantieni and Heywood, 1998

The maximum dynamic increment for bridge vertical deflection for each of the bridge/vehicle parameter configurations tested for the case “without axle-hop bump” is given in Table IV.2 together with other significant test parameters.

In summary, the response of the bridges to the passage of the test vehicles was consistent with the laws of physics in that the largest dynamic responses occurred when either the body bounce or axle-hop frequency of the test vehicle corresponded to the natural frequencies, especially the fundamental natural frequency, of the bridge in bending. This effect is called "frequency-matching". The surface profile of the bridge and its approaches (up to 50 m in length) was fundamental to the response of the vehicle suspension and in turn to the dynamic response of the bridge. The case of a smooth bridge and approach profile for short-span bridges could not be covered by the experiments under discussion.

**Table IV.2. Maximum dynamic increments  $\phi_{\max}$  for vertical bridge deflection measured in a specific significant bridge for passages without axle-hop bump**

Bridge	1st freq. (Hz)	Damping (per cent)	Pavement condition <sup>1</sup>	Frequency matching	$\phi_{\max}$ steel (%)	$\phi_{\max}$ air (%)
Sort	1.62	1.0	A	body-bounce, air	10	26
Deibüel	3.01	0.8	A	body-bounce, steel	21	5
Föss	4.44	1.6	B	none	15	12
Lawsons	5.1	1.0	A	none	6	3
Coxs	10.2	4.5	A	axle-hop	28	18
Camerons Creek	11.3	1.5	B-C	axle-hop	110	75 (vehicle 1) 137 (vehicle 2)
Cromarty	9.5	2.6	B-C	axle-hop	109	50

<sup>1</sup>According to ISO (1995).

Source: Cantieni and Heywood, 1998

#### *Medium- to long-span bridges*

In the case of a smooth bridge and approach profile on medium- to long- span bridges, the influence of the vehicle suspension on dynamic wheel load and bridge response magnitudes was not very significant. Under these circumstances, vehicle body-bounce vibrations were excited almost exclusively, and with a constant frequency at all speeds, with the effect that frequency-matching occurred only at the corresponding low frequencies. The following results were observed.

- The air-suspended test vehicle induced larger dynamic responses in a bridge with a fundamental natural frequency ( $f$ ) in the vicinity of 1.6 Hz [maximum span ( $L$ )  $\approx$  70 m] than in bridges with natural frequencies outside this range. The increases in dynamic increment observed were insufficient to warrant any increases in allowance for dynamic effects made in bridge design.
- The steel-suspended test vehicle induced larger dynamic responses in a bridge with a fundamental natural frequency ( $f$ ) in the vicinity of 3.0 Hz ( $L \approx$  40 m) than in bridges with natural frequencies outside this range. The dynamic increments were of the same non-critical order of magnitude as those in the case mentioned above.

- Neither the steel- nor the air-suspended vehicles induced significant dynamic responses in the bridges with natural frequencies between the body bounce and the axle-hop frequencies, i.e.  $f = 4.4 \text{ Hz}$  ( $L \approx 31 \text{ m}$ ) and  $f = 5.1 \text{ Hz}$  ( $L \approx 23 \text{ m}$ ).

The case of a rough bridge and approach profile for medium- to long-span bridges could not be considered. Neither was the case of a rough bridge and a smooth approach considered, although the case of a rough approach and a smooth bridge was included.

### *Short-span bridges*

The experiments did cover the case of a rough bridge and approach profile for short-span bridges ( $f \approx 10 \text{ Hz}$ ,  $L \approx 10 \text{ m}$ ). The results of these tests were as follows:

- When air-suspended vehicles travelled at critical speeds over axle-hop inducing features, large dynamic responses and multiple fatigue cycles were observed. These responses were up to 4.5 times the dynamic load allowance specified in bridge design. Where axle hop was not induced, the dynamic response was much smaller.
- A probable explanation for this is the fact that the very limited dynamic load sharing in air suspensions allows the axles in a group to vibrate in phase at axle-hop frequencies. “Cross-talk” between conventional steel leaf suspensions limits this possibility. This difference in behaviour was crucial in the strength of the dynamic coupling between air suspensions and short-span bridges.
- Damping of both the bridge and the vehicle suspension were found to be fundamental to controlling the dynamics in short-span bridges.
- High bridge damping reduced the respective structure’s ability to amplify dynamic wheel load effects even in the case of frequency-matching (in the axle-hop frequency range).
- Air suspensions with inadequate damping are potentially very damaging to short-span bridges.

The level of bridge damping proved to be very significant for short-span bridges but not for medium- to long- span bridges. This may be due to the fact that damping values are smaller and confined to a much narrower range for medium- to long-span bridges compared with short-span bridges. Medium- to long-span bridges show damping values ( $\zeta$ ) between 0.8 and 2 per cent whereas for short-span bridges the range is between 1 and 5 per cent.

### *Comparison with the results of standard Swiss tests*

The maximum dynamic increment for each DIVINE bridge/vehicle configuration was compared with the results of similar Swiss tests using two-axle rigid trucks fitted with steel leaf suspensions. The following comments regarding this comparison, illustrated in Figure IV.18, may be made:

- in the body bounce frequency range ( $f$ ) between 1.5 and 3 Hz, the dynamic increments are largest for the vehicle (suspension) that has a natural body bounce frequency that matches the fundamental natural frequency of the bridge;

- in the case of frequency matching at  $f \approx 1.5$  Hz, the maximum dynamic increment measured intersects the solid line given in Figure IV.18, indicating the upper limit of dynamic increments observed with earlier tests;
- in the axle hop frequency range between 8 and 15 Hz, dynamic increments lying well above the "Swiss test limit" are observed with the exception of the results for a highly damped bridge;
- between the body bounce and axle hop frequencies, the dynamic bridge response is relatively small and the type of suspension is less important;
- heavy vehicles can couple dynamically with both long-span and short-span bridges;
- the quality of the road profile is a very important parameter in determining the dynamic bridge response;
- very limited testing has been previously undertaken on bridges with natural frequencies in the vehicle axle hop range.

**Figure IV.18. Dynamic increments as a function of bridge fundamental frequency incorporating DIVINE test data**

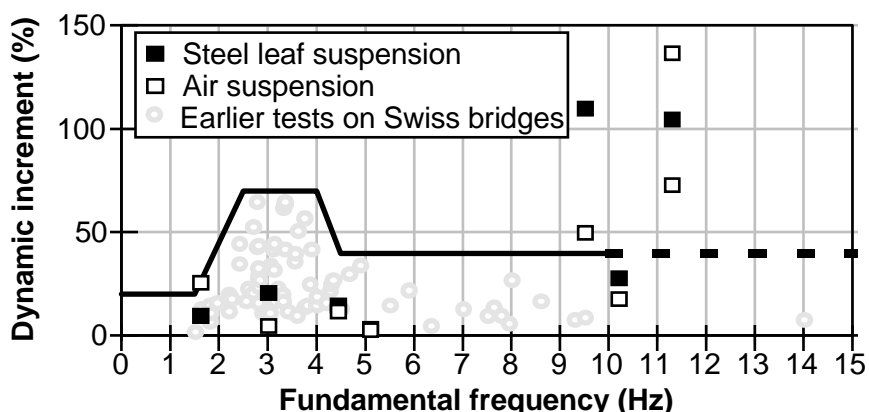

Source: Cantieni and Heywood, 1998

*General discussion of Element 6 results*

The main parameters governing the problem of dynamic bridge response to the crossing of a single heavy commercial vehicle were found to be:

- the natural properties of the bridge (frequencies, damping, mode shapes);
- the frequencies and magnitudes of the vehicle's dynamic wheel loads;
- the damping capacity of the vehicle suspension system;

- unevenness in the bridge deck and approach pavement; and
- vehicle speed.

One of these parameters, the natural properties of the bridge, is constant and independent of any external influence meaning that it can be varied only by choosing different bridges.

Pavement unevenness is also more or less constant. However, some deterioration over time and the possible presence of artificial obstacles has to be considered. Variation in the overall pavement unevenness for a given test track is almost impossible to achieve due to its limited length.

The frequencies and magnitudes of the vehicle dynamic wheel loads are closely inter-related with three other parameters, namely the pavement unevenness, the (highly variable) vehicle speed and the (uncertain) vehicle suspension damping capacity. This close and very complex inter-relationship explains why it is not possible to treat the problem of dynamic bridge response to the crossing of heavy vehicles in an isolated way. However, a number of basic issues are clear:

- No dynamic amplification (quasi-resonance) occurs without frequency-matching. The model of system coupling is suitable for medium- to long-span bridges. For short-span bridges, the model of a forced vibration process is more appropriate (see Chapter III).
- High dynamic wheel loads due to rough pavement and/or lack of vehicle suspension damping capacity yield high dynamic bridge response.
- In the case of frequency-matching, high dynamic wheel loads yield very high dynamic bridge response. This case is usually not covered by bridge design codes.

The DIVINE experiments answered only in part the questions formulated at the beginning of the project. This was due to the fact that neither the case of a short-span bridge with a smooth bridge and approach profile nor the case of a medium- to long-span bridge with a rough bridge and approach profile could be covered with the DIVINE tests. In addition, it was not possible to investigate the problem of multiple vehicle presence on the bridges.

In spite of these limitations, the DIVINE tests found that:

- For frequency-matching conditions at  $f \approx 1.5$  to 1.8 Hz, excessive bridge vibrations are not to be expected with air-suspended vehicles on bridges with smooth pavement conditions.
- For frequency-matching conditions at  $f \approx 10$  Hz, excessive bridge vibrations can be expected with both steel- and air-suspended vehicles operating on bridges with average to rough pavement conditions. The situation is especially severe if the shock absorbers on an air-suspended vehicle are ineffective.

Questions which remain open are as follows:

- For frequency-matching conditions at  $f \approx 1.5$  to 1.8 Hz, what could the maximum dynamic increment be in the case of average to rough pavement conditions?
- For frequency-matching conditions at  $f \approx 10$  Hz, what pavement quality and suspension damping performance are necessary to avoid excessive bridge vibrations?

To answer these questions, further tests or analytical studies are necessary.

## **IV.2 Vehicle suspension effects on pavement condition and performance**

Element 1 of the DIVINE Project provided the first ever comparison of changes in pavement condition related to the difference in dynamic loading produced by two suspension systems. In this test, a specially constructed and instrumented indoor pavement with an average circumference of 58 metres was subjected to 1.7 million cycles of loading by two diametrically opposed test wheels travelling at a speed of approximately 45 km/h in separate wheel paths. One test wheel was fitted with a steel suspension and was operated in the “outer” wheel path (OWP). The other was fitted with an air suspension and operated in the “inner” wheel path (IWP). Both were loaded to a static load of 49 kN. “Wide single” tyres were fitted to both test wheels. As this test was fully enclosed, the influence of diurnal temperature variations was attenuated.

All of the key vehicle-pavement dynamic system characteristics described in Chapter III were measured in this test. Because the specific aim of the test was to compare the pavement wear effects of two sets of dynamic loading produced by two different suspensions, considerable effort was devoted to ensuring that the two suspensions were considered under conditions as close to identical as possible.

### **IV.2.1 Details of test conditions**

Full details of the work are contained in the final report (Kenis and Wang, 1997). A summary of the findings follows.

#### *Test pavement*

The test pavement consisted of a flexible bituminous surfacing of average thickness 88 mm over a prepared granular base course of 199 mm average thickness and selected subgrade with a CBR of 12 per cent. By European standards, this is considered a “thin” pavement -- i.e. bituminous layer thickness of 150 mm to 200 mm is typical -- for the most heavily trafficked roads. Extensive testing of the pavement material properties and structural and environmental properties was carried out before and during construction, during trafficking and after trafficking (Kenis and Wang, 1997; Steven *et al.*, 1996a).

The pavement tests confirmed that the structural properties of the two wheel paths at construction were not significantly different (Steven *et al.*, 1996b), although the OWP was in some respects slightly stronger. The circumferential variability of the pavement’s mechanical and structural properties was also considered to be relatively small. The longitudinal (circumferential) surface unevenness was greater than anticipated and the IWP was a little rougher than the OWP at the commencement of the test.

#### *Suspensions*

The two suspensions fitted to the test wheels, although not commercially produced suspension systems, were fabricated from typical heavy vehicle suspension components and had dynamic behaviour similar to typical steel and air suspensions fitted to heavy trucks.

Drop tests (Sharp and Moffatt, 1996) of the two suspensions showed that the air suspension was very similar in frequency and damping to typical heavy vehicle air suspensions, while the steel suspension had a somewhat lower frequency and higher damping than would be expected for typical truck leaf spring mechanical suspensions. The drop tests indicated that there was perhaps less difference in the “road-friendliness” of the two generic suspension types than would occur in practice. However, there was a substantial difference in the actual dynamic wheel forces (measured as DLCs) for the two test wheels and it appears that the dynamic behaviour of the test steel suspension, when attached to the CAPTIF rotating arm, produced dynamic wheel forces similar to an actual truck steel suspension.

#### ***IV.2.2 Summarised comparison of suspension effects***

Table IV.3 summarises the differences in all the measured characteristics of the vehicle-pavement interaction for the accelerated dynamic loading test under air suspension and steel suspension. It is apparent that by most measures there was a significant increase in effect on the pavement under the action of the steel suspension. However, the analysis also showed that pavement factors, most notably variability in structural strength, also influenced the outcome of the test.

When comparing suspension effects on pavements of very similar and highly uniform structural strength (coefficient of variation of 10 per cent), the most clear-cut effect of the steel suspension related to profile changes (see Figures IV.19 and IV.20). The steel suspension produced a 15 per cent increase in roughness (as measured by the IRI). Local pavement cracking was also approximately 10 per cent greater under the steel suspension.

These differences in suspension effects are considered to be conservative in so far as:

- the steel-suspended test wheel travelled 9 per cent faster than the air-suspended test wheel, which should have resulted in lower pavement strains being induced in the OWP;
- the initial roughness of the IWP, as trafficked by the air suspension, was 17 per cent higher, which increased the dynamic loading generated by the air suspension;
- the CAPTIF test wheels may have produced significant lateral "scrubbing" forces and the lateral force may have been greater in the IWP than in the OWP.

The test also demonstrated that the dynamic loading of the steel suspension interacted with the structural variability of the pavement to produce pavement deformation and rutting. This was most evident when the effects of the OWP structural weakness near Station 21 were included in the analysis. Specifically, a structural decrement of 30 per cent along with a dynamic loading increment of 13 - 41 per cent (this increased during the test) produced a large local rut that was approximately three times the depth of the other ruts that were induced under load. This interaction of the steel suspension and the pavement structure also produced 36 per cent more total pavement cracking distress.

Of course, this interactive effect of the steel suspension and the pavement structure cannot be compared directly with any such effect which may have been produced by the air suspension, because the 30 per cent structural decrement only occurred in the outer wheel path. However, there was very little evidence that the dynamic loading generated by the air suspension, which was relatively small and produced a maximum dynamic loading increment throughout the test of 10 per cent, had any measurable influence on rutting or pavement deformation.

**Table IV.3. Comparative pavement effects of the two suspension systems**

Measured characteristic	Air-suspended test wheel (inner wheel path)	Steel-suspended test wheel (outer wheel path)	Comparison of pavement effects
Longitudinal (circumferential) pavement profile - IRI	Initially relatively high (4.8); fluctuated slightly through test but did not exceed 4.8	Initially 4.1; increased throughout test, up to 4.8	Steel suspension increased IRI relatively by 15 per cent
- waviness (10 m wavelengths)	Very little change	Significant change throughout test	Steel suspension effect 80 times higher
Pavement serviceability - PSI	Some reduction through test	Slightly more deterioration through test	Some evidence of greater deterioration under steel suspension
Rutting (excluding the large rut) - mean rut depth	8.94 mm	8.44 mm	Steel suspension produced 6 per cent less average rut depth
- sd of rut depth	1.74 mm	1.95 mm	Steel suspension produced 12-18 per cent more variability in rut depth
- coeff. of variation	0.195 mm	0.231 mm	
- max. rut depth	12.4 mm	14 mm	12 per cent greater under steel suspension
Rutting (including the large rut) - mean rut depth	8.75 mm	10.5 mm	Steel suspension produced 20 per cent more average rut depth
- max. rut depth	12.4 mm	36.9 mm	Structural weakness of 30 per cent and impact factor of 1.13 - 1.4 under steel suspension produced 200 per cent greater maximum rut depth
Cracking - total extent	64 m	87 m	Steel suspension produced 36 per cent more cracking (all data)
- intensity (29th worst station)	0.99 m per station	1.10 m per station	On average, steel suspension produced 10 per cent more local cracking

Source: CAPTIF

Figure IV.19. Variation in inner wheel path (air suspension) profiles after repeated loading

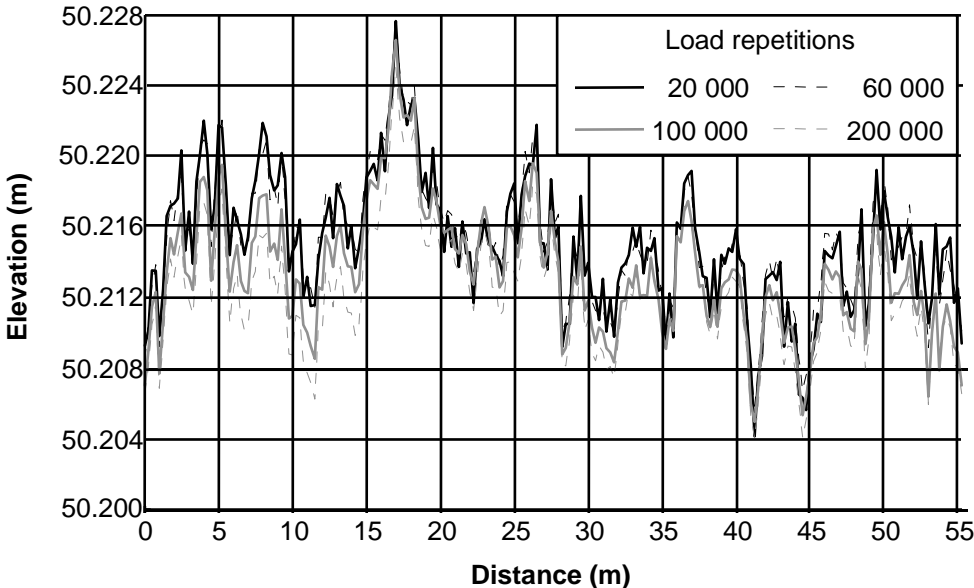

Source: CAPTIF

Figure IV.20. Variation in outer wheel path (steel suspension) profiles after repeated loading

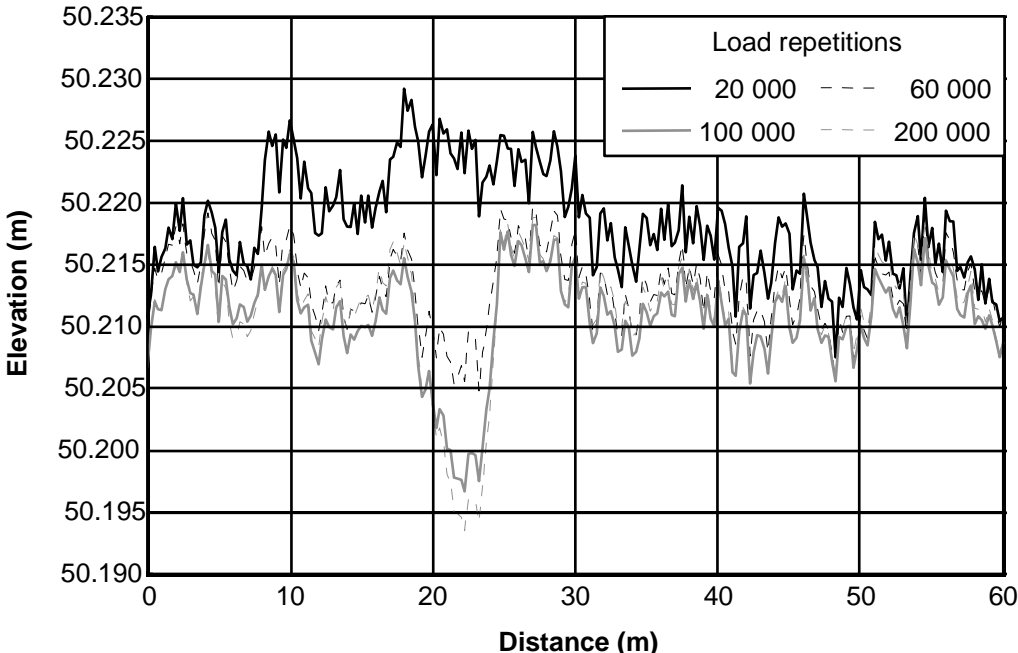

Source: CAPTIF

### *IV.2.3 Implications for suspension effects on highway pavements*

The results of the accelerated dynamic loading test give some important insights into the effects of suspension characteristics and dynamic loading on pavement performance. However, the application of these findings to real trucks and highway pavements is extremely difficult and requires careful consideration from a number of points of view.

#### *Magnitude of dynamic loading*

Both the static test wheel loads and, in the case of the steel suspension, the dynamic loading, were relatively high in the accelerated dynamic pavement test. To this extent, they were representative of the range of loading generated by trucks in service.

#### *Tyre-pavement contact stresses*

Previous research (Bonaquist, 1992) has confirmed that the use of wide single tyres in the CAPTIF test, in place of dual tyres, would have caused more localised loading on the surfacing and should have caused increased pavement responses compared with dual-wheel loading. However, results from Element 2 suggest that, for thinner pavements such as the one tested at CAPTIF, the influence of dynamic loading on pavement surface strains is lessened by changes in the shape of the tyre contact patch.

#### *Significance of profile changes*

One of the major problems in extending the CAPTIF test results to highway pavements is the representation of longitudinal profile in a way that is meaningful for both a relatively small-scale test pavement and a highway. It was found that the IRI and PSI were of limited use for the circular test track although the steel suspension increased the IRI of an already-rough pavement by 15 per cent, while the IRI of the pavement under the air suspension was virtually unaffected by extensive trafficking.

The ISO comparative density index of pavement unevenness, also referred to as the general unevenness, was found to provide good results and could be transferred to highway practice. Again, the CAPTIF track is much shorter than is recommended for this type of profile analysis and little data are currently available for highways in this format. Figure IV.21 shows the change in comparative density throughout the test for both wheel paths. It is apparent that the unevenness of the inner wheel path increased only slightly throughout the test, while that of the outer wheel path increased significantly. This increase occurred not only during the formation of the large isolated "rut" but also after it had stabilised. Fitting a regression line to the comparative density function from 400 000 loads onwards showed that the outer wheel path unevenness value increased at a rate 80 times greater than for the inner.

Such an analysis suggests that the number of cycles to bring about a given increase in unevenness is very much less (a factor of approximately 80) for the steel suspension than for the air suspension. Pavement deformations under the air suspension were mainly related to structural variability of the pavement, while those under the steel suspension were affected by both structural variability and dynamic loading in an interactive manner. Given the high degree of dynamic load concentration in the CAPTIF test and the interactive role of pavement structural variability, it is difficult to translate the effects on unevenness of suspension, not to mention dynamic loading, from CAPTIF to highway conditions. However, the fact that the air suspension had very little influence on pavement unevenness while the steel

suspension had a much larger influence suggests a strong potential influence of suspension type on pavement unevenness in practice.

**Figure IV.21. Progression of pavement unevenness (comparative density)**

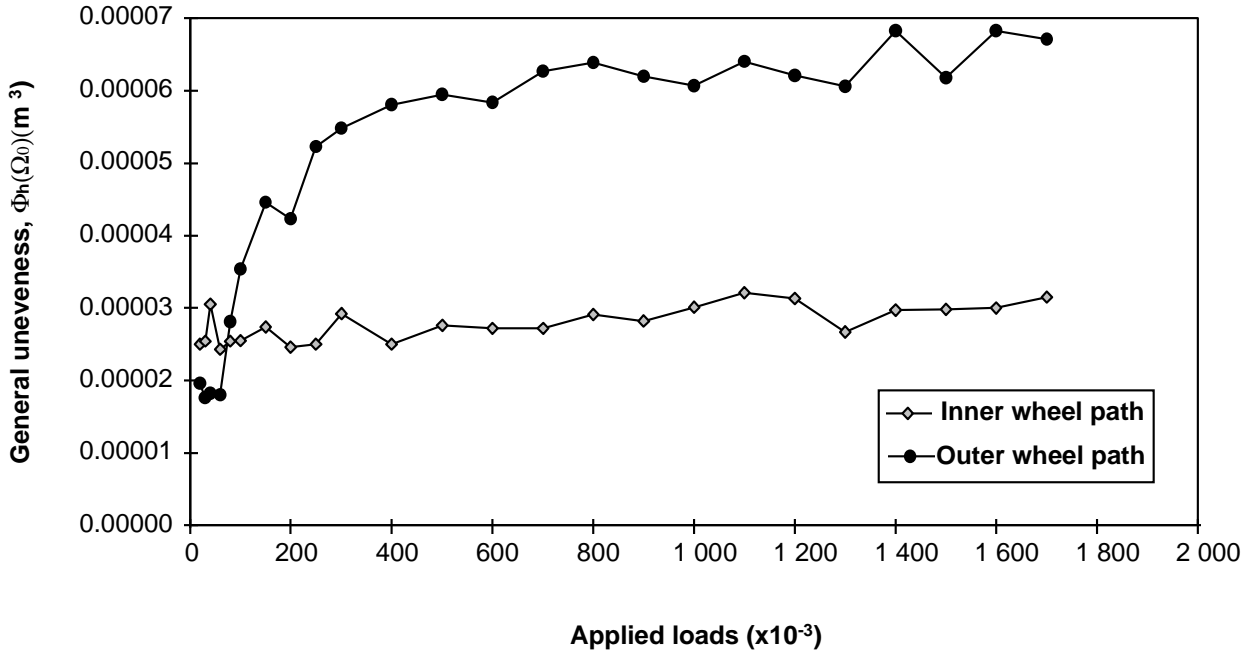

Source: CAPTIF

*Significance of rutting*

The relatively high static wheel load in the CAPTIF test, combined with the use of wide single tyres and the relatively channelised trafficking in the wheel paths, should have accelerated the development of rutting. Nevertheless, general levels of rutting were small, except for the large rut near Station 21 in the outer wheel path where the weakened base course was significantly deformed in coincidence with the application of a dynamic loading peak.

Despite the generally small degree of rutting evident in the CAPTIF indoor test pavement and the fact that the mean rut depths were the same in the two wheel paths, there were differences in the observed maximum rut depths between the two wheel paths. As well, the maximum rut depth under the steel suspension was influenced by dynamic loading. The progression of maximum rut depth in the two wheel paths, shown in Figure IV.22, shows no sign of an accelerating damage trend which could be extrapolated to some level of pavement failure to determine the relative pavement life under the two suspensions. However, if a maximum rut depth in the range 11 - 12 mm is taken as a critical level, then analysis of the rutting curves shown in Figure IV.22 shows that the air suspension would achieve 45 - 65 per cent more load cycles than the steel suspension to produce the same rutting distress. A similar analysis of the standard deviation of rut depth indicates that the air suspension would achieve 35 - 55 per cent more load cycles. The significance of this result needs to be tempered by the small overall amount of rutting distress which occurred, the accuracy of the rutting measurements and the fact that the variability in rut depth was used rather than the mean value.

Figure IV.22. Maximum rut depth versus number of load cycles

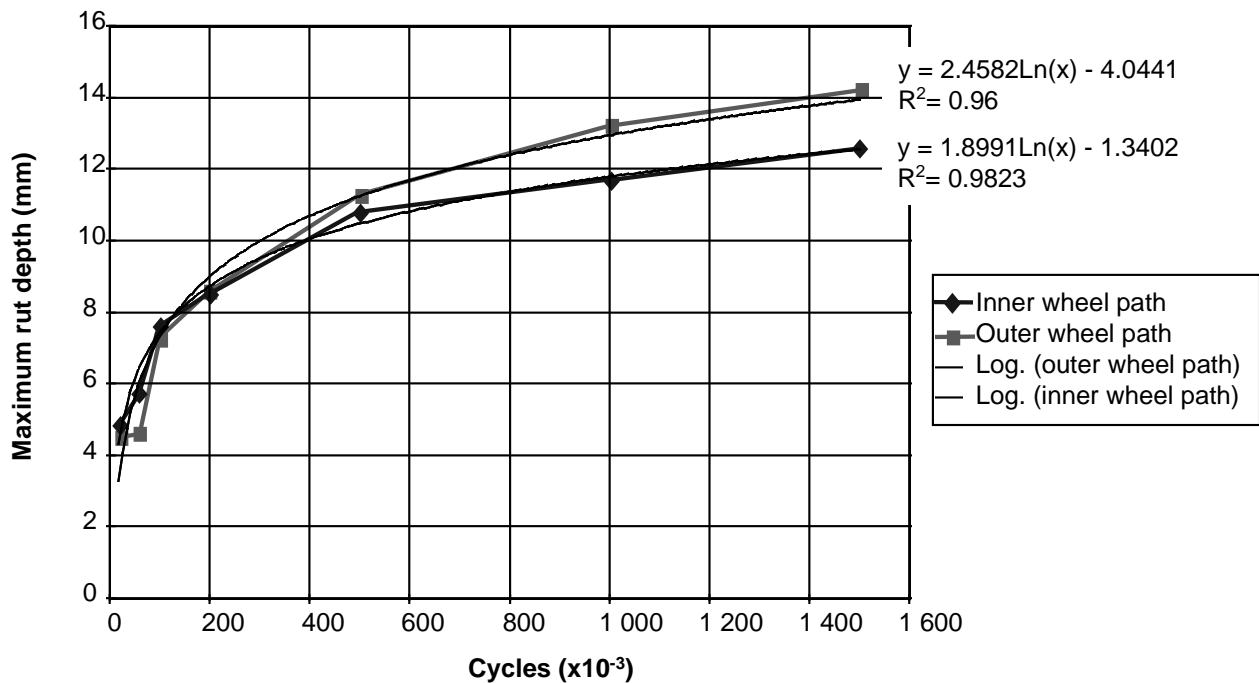

Source: CAPTIF

*Significance of cracking*

Cracking of the surfacing did not commence until 840 000 cycles were completed. The nature of the cracking was unexpected in that the cracks tended to originate at the top of the surfacing and did not propagate all the way through. The unusual nature of this cracking could have been caused by the significant lateral tyre forces generated by the CAPTIF test rig. It was found that the intensity of cracking was related to variations in pavement structural strength, and, as already discussed, it appeared to have only a weak relationship to the location of peaks in dynamic loading.

In order to provide some information concerning relative pavement lives under the air and steel suspensions, an analysis of the number of stations reaching certain levels of cracking intensity was carried out under the steel suspension.

Figure IV.23 shows the progression of the percentage of stations with total crack length exceeding a level of 2.5 m linear length of cracking per station. This level was selected to show the more rapid accumulation of stations with significant cracking distress under the steel suspension. Analysis of these curves showed that the number of test cycles required to produce a 2.5 m linear length of cracking distress in 10 per cent of stations was approximately 30 per cent less for the steel suspension (see also Table IV.3).

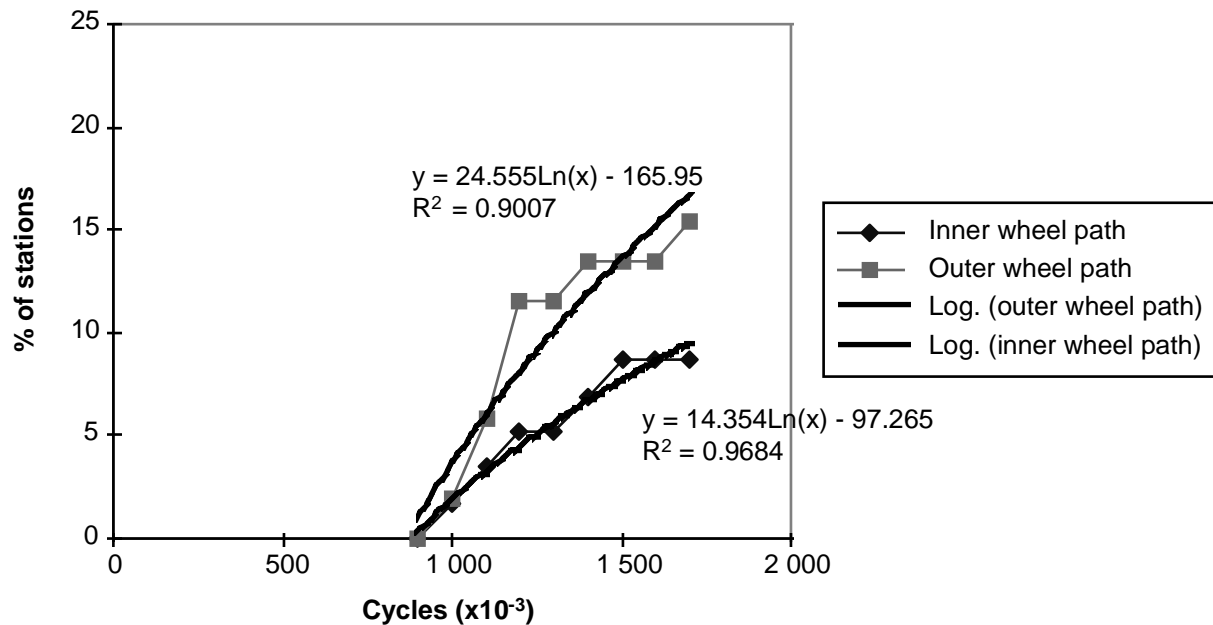
**Figure IV.23. Progression of cracking damage**

Source: CAPTIF

#### *Significance of spatial repeatability*

The dynamic loading applied in the CAPTIF test was highly repeatable. After the test wheel had traversed one revolution of the CAPTIF circular track, the dynamic loading quickly took on a pattern which was altered only by profile changes. The most significant profile changes occurred in the steel suspension wheel path, particularly during the relatively early stages of the test.

Spatial repeatability of dynamic loading on actual highways will be much less than that involved in the CAPTIF test.

#### *Overall implications for “road-friendliness”*

There are significant difficulties in extrapolating the results of the accelerated dynamic loading test to real highways and real vehicles. Some factors associated with the test would tend to increase the severity of the test relative to actual road conditions while some others would tend to decrease it.

The rate of accumulation of damage in the test pavement is likely to have been increased because of:

- the selection of a relatively thin bituminous test pavement;
- the relatively channelised tracking in the same wheel path;
- the high degree of spatial repeatability of dynamic loading around the circumference of the two wheel paths; and

- the significant lateral forces generated by the test wheels.

On the other hand, the potential for pavement damage would have been reduced by the lack of environmental influences such as extreme temperature variations and the ingress of moisture into the base layers and the subgrade.

Given that relatively little damage accrued to the pavement, despite the high intensity of trafficking, it would appear that the latter factors tended to prevail in limiting the amount of pavement damage generated during the test.

Based on the amount of rutting and cracking distress as well as roughness changes, the test produced evidence of longer pavement life under the air suspension than under the steel suspension. Some results for pavement unevenness showed that the air suspension would require approximately 80 times the trafficking to produce the same increment in unevenness. Some results for cracking distress showed that the air suspension required 30 per cent more load cycles to produce the same level of high-intensity cracking as the steel suspension. Some results for the variability of rut depth and its peak values showed that the air suspension could accommodate 35-65 per cent more cycles to bring about the same level of deterioration. Other more conventional indicators of pavement distress, such as mean rut depth and total cracking, showed little influence according to suspension type.

The stronger influence of the steel suspension on pavement unevenness, or roughness, demonstrates that suspensions and dynamic loading have important implications for pavement-friendliness, especially in view of the increasingly important role of pavement roughness in pavement management systems. Any general estimate of the magnitude of the benefit of air suspension-based results such as CAPTIF would need to be factored by:

- the rather lower degree of spatial repeatability evident for trucks operating on highways;
- the thicker, stronger pavements used in many countries on major truck routes; and
- the environmental influences acting on real pavements.

Insufficient scientific information is available from the DIVINE Project to make a firm quantitative estimate. However, the progression of significant aspects of pavement unevenness is likely to be several times as rapid under loading from steel suspension than it would be under air suspension, especially on thinner flexible pavement structures.

#### *Implications for pavement analysis*

- It was not the intention in the DIVINE Project to examine existing pavement life prediction models or pavement performance models, but rather to rank the relative performance of a single, uniform pavement subject to two different dynamic loads generated by two suspension types. Existing life prediction models were simply used to assist in the design of a pavement that, under the specified static load, would be likely to reach an unacceptable level of performance, in terms of both surface cracking and surface deformation, in an approximately equal period of time.
- Life-prediction models are typically derived from response to load parameters, particularly tensile strain at the bottom of the bituminous layer and compressive strain on the surface of

the subgrade. The observed failure modes -- i.e. cracking of the bituminous layer at the surface and deformation in the base layer -- were not in line with life-prediction models commonly in use and could have been caused by characteristics of the CAPTIF test rig. However, the failure modes observed at CAPTIF have also been observed elsewhere.

- On the basis of the CAPTIF test, it is essential that pavement structural variability and dynamic loading be included in performance models.
- More emphasis should be placed on accelerated pavement tests for monitoring surface profile at construction and changes in profile and roughness over time. The difficulty, of course, is associated with the generally short length of pavements tested by these facilities and the inappropriateness of current technology to derive meaningful data in these situations that can be realistically applied in practice.
- By definition, any accelerated pavement test should be conducted in tandem with long-term pavement performance studies and laboratory characterisation of the test materials because accelerated testing provides the link between these two activities. The lack of reliable, controlled field data is a major inhibitor to the development of meaningful pavement performance models that can be used with confidence by the practitioner.
- Though IRI provides a useful measure of pavement condition, it is not suited to accelerated testing facilities. PSD-based profile measures provide a better measure on short tracks and allow better comparison between field tests and accelerated tests.

### IV.3 Vehicle assessment for “road-friendliness”

To be classified as “road-friendly”, a suspension must, to the greatest extent possible, isolate the vehicle from road unevenness so that dynamic wheel loading is minimised for given static loads. The suspension should perform well on the complete range of road roughness profiles. It is beneficial for heavy truck suspensions to perform well on relatively new roads in good condition as well as on rougher roads nearing the end of their useful life.

There is good evidence (Woodrooffe, 1997; Magnusson *et al.*, 1984; Cole and Cebon, 1994; Rakheja and Woodrooffe, 1994) that low sprung mass frequency, reduced unsprung mass acceleration, adequate viscous damping and reduced Coulomb friction are the major contributors to suspension road-friendliness. The connection between hydraulic damping and suspension road-friendliness is a significant concern because damping, when using the Directive 92/7/EEC test protocol (Council of the European Communities, 1992), was found to be the most difficult parameter to measure (Sweatman, 1994; OECD Road Transport Research, 1992; Aurell, 1991). The reasons for the difficulties in the measurement of damping are related to the influence of such variations as vehicle response mode, damper active stroke length, drop height, damper fluid temperature and the influence of wear during the service life of the damper.

A previous OECD study (1992) found difficulties in testing suspensions. The difficulties included standardising the spring deflection and temperature as well as simultaneously applying the excitation to all axles in an axle group. The study also found that the analysis of the results suffered from a lack of accuracy in interpreting the decaying force-time characteristic and therefore recommended that the relative contributions of friction and viscous damping be considered.

It is essential that modifications to the suspension system for road-friendliness should not have an adverse effect on vehicle safety. Indeed, if possible, any developments to make suspensions more road-friendly should aim to improve safety through improvements in vehicle braking, roll dynamics and directional control.

#### IV.3.1 The EC drop test

The Council of European Communities Directive (1992) defines a road-friendly suspension and how to test for it. Underlying this Directive is the assumption that air suspensions, for which at least 75 per cent of the spring effect is caused by the air spring, qualify as being road-friendly. The test protocol applies to non-air suspended driven axles and defines an “equivalent to air” suspension as one meeting the following component and performance requirements:

- The axle must have dual tyres.
- The suspension must use hydraulic dampers. The vehicle must have a sprung mass frequency no greater than 2.0 Hz.
- The damping ratio (D) of the sprung mass must be more than 20 per cent of critical damping (with dampers fitted).
- The sprung mass must have a damping ratio no more than 50 per cent of D when all dampers are removed.

To prove compliance with the test requirements the following methods can be used:

- Traverse a specified 80 mm step (see Figure IV.24) at 5 km/h and analyse the suspension frequency and damping from the transient time history occurring after the ramp.
- Pull the vehicle chassis down so that the driving axle load is 1.5 times its maximum static load value. Release the vehicle and analyse the subsequent oscillation.
- Pull the chassis up so that the sprung mass is lifted 80 mm above the static position. Release the vehicle and analyse the subsequent oscillation.

**Figure IV.24. EC suspension test ramp**

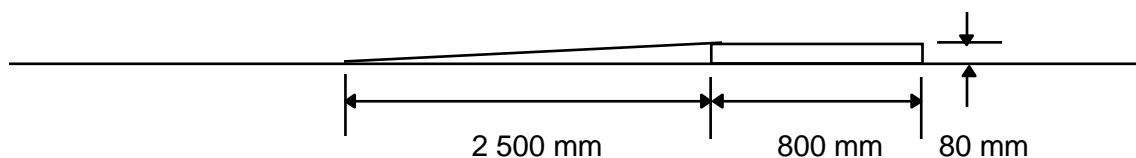

Source: European Commission

Based on research conducted to date, evidence strongly supports the appropriateness of the variables examined by Directive 92/7/EEC. That is, both frequency and damping characteristics are the key attributes to use when defining road-friendliness. However, the test methods described by Directive are not necessarily the only, or best, methods for proving road-friendliness. In addition, there is room for adjustment to the frequency and damping target values. This is discussed further in Section IV.3.3.

### ***IV.3.2 Vehicle testing***

Vehicle testing was divided into two separate tasks.

- road simulator experiments; and
- suspension testing experiments.

#### *Road simulator experiment*

The first objective of the road simulator experiment was to determine, in relation to two-axle trucks, the accuracy with which a four-actuator road simulator could reproduce dynamic wheel loads previously measured during over-the-road tests. The second objective was to investigate, in relation to a five-axle tractor/semi-trailer, the difference between the wheel loading performance of the trailer suspension evaluated in isolation versus its performance when incorporated in a vehicle system.

The road simulator test procedure consisted of:

1. selecting road sections of different road unevenness (from “good to poor”) and measuring their wheel track longitudinal profiles;
2. running tests over the selected sections with research vehicles instrumented to measure dynamic wheel loads and vehicle speed;
3. digitally constructing the desired road-simulator actuator vertical displacement signals based on the longitudinal elevation profiles, the speeds and the vehicle inter-axle spacing;
4. reproducing the desired vertical displacements using a four-actuator road simulator (Figures IV.25 and IV.26) to drive the wheels of two adjacent axles of the research vehicles and measuring dynamic wheel loads.

The test procedure produced dynamic wheel load measurements from the on-road sites for comparison with dynamic wheel load measurements from road simulator tests using road profiles that were identical to those found in the on-road measurements.

The shaker was able to approximate the over-the-road response of a simple two axle vehicle with some disagreement in the roll dynamics. The experiments proved that each axle of a multi-axle vehicle must be excited in order to approximate true vehicle response. The experiments demonstrated that it was not possible to characterise a suspension by exciting only selected axles of a vehicle. Nevertheless, the shaker tests confirmed that instrumented vehicles can produce very accurate measurements of dynamic wheel loads (better than 3 per cent of DLC), provided that the correct procedures are used to instrument and calibrate the axle load measurement system.

Figure IV.25. TRL instrumented vehicle on NRC shaker

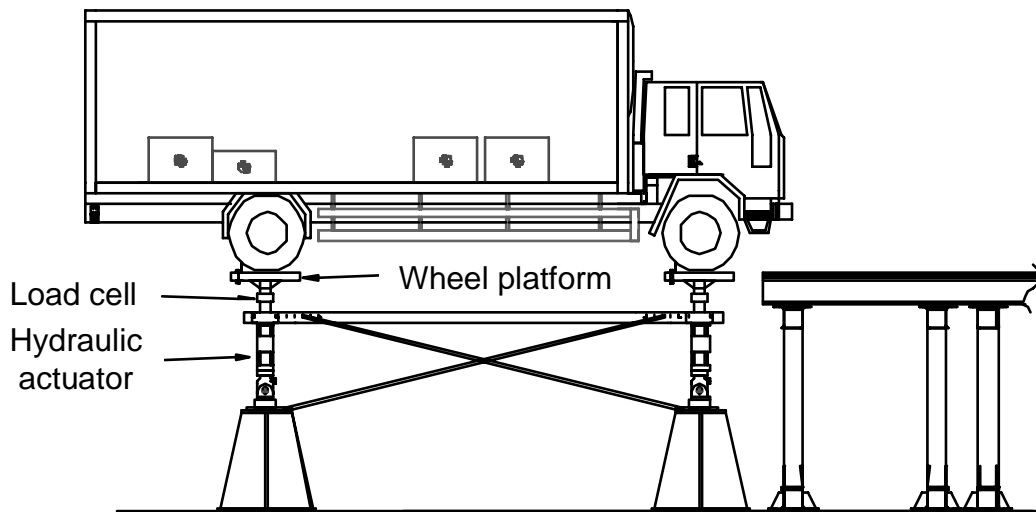
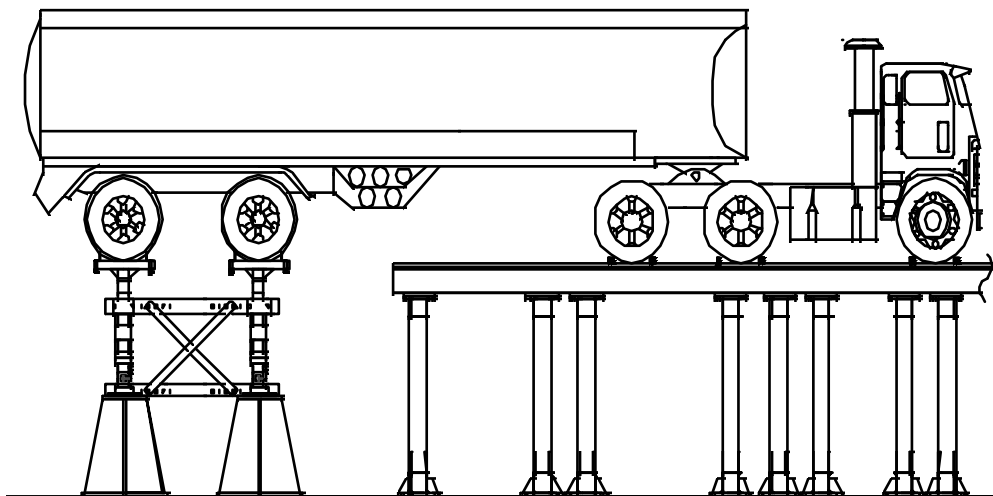

Figure IV.26. NRC instrumented vehicle on NRC shaker



*Suspension testing experiments*

A set of experiments were conducted on three different tandem axle suspensions using a specially built pendulum trailer that acted as a single degree of freedom mass system pinned at one end and supported by the test suspension at the other as shown in Figure IV.27. The test suspension was supported at each wheel by a hydraulic actuator (NRC shaker) that was computer driven to replicate real and virtual road profiles as well as constant displacement sinusoidal inputs and discrete events such as drop tests.

The objective was to explore the means by which suspensions can be evaluated for road-friendliness. The three generic suspensions examined were:

- trailing arm air suspension;
- four-spring steel leaf suspension with interleaf friction; and
- rubber suspended walking beam suspension.

All tests were conducted with tyres inflated to 7 Bar (103 psi) and individual axle loads of 90 kN. Each wheel of the suspension was supported by an actuator and the left and right wheels of a common axle were excited with identical signals to eliminate roll. To examine load equalisation, lead and trailing axles were displaced vertically under quasi-static conditions relative to each other.

Axle drop tests were simulated by subjecting lead and trailing axles to a simulated EC Directive drop test ramp at a vehicle speed of 5 km/h. The drop tests were conducted by dropping the axles both sequentially and simultaneously.

**Figure IV.27. Schematic drawing of pendulum test trailer**

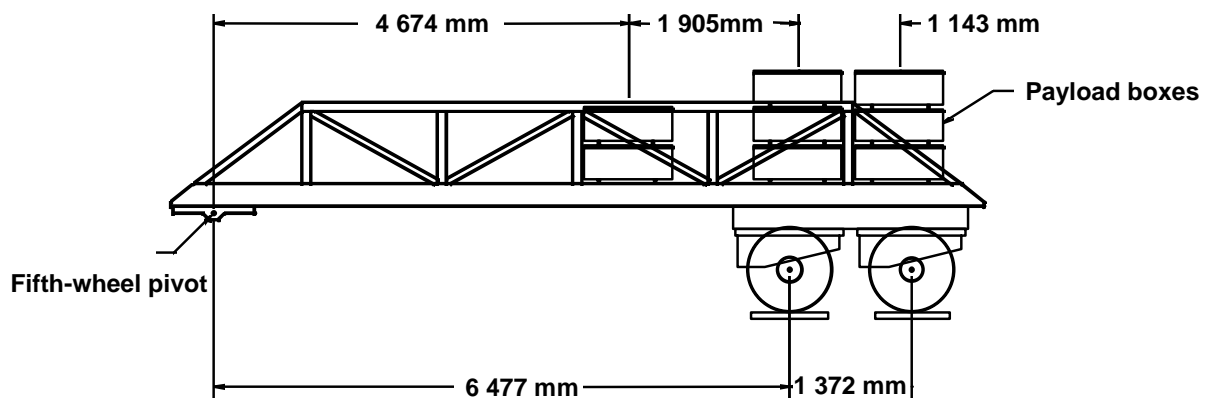

Source: NRC

The suspensions were excited by DIVINE Road Profiles and “Virtual Road Profiles” representing “good”, “average” and “poor” roads. Constant amplitude sinusoidal tests were conducted over a frequency range of DC to 20 Hz. The sinusoidal tests were conducted (i) with both axles of the tandem axle suspensions excited in phase and (ii) with both axles of the tandem suspensions excited 180 degrees out of phase.

#### Drop test

The drop test was structured to replicate the compliance test outlined in the EC drop test Directive 92/7/EEC that defines the equivalency of non-air suspensions to air suspensions. Tests were conducted on the tandem axle suspensions using both the sequential and simultaneous drop test techniques. The sequential drop test did not produce useful results and proved to be an impractical test method for multi axle suspensions. The simultaneous drop test did produce satisfactory results and simultaneous drop tests were conducted to examine the sensitivity of the damping parameter to drop

heights of 40, 60, 80, 100 and 120 mm. Directive 92/7/EEC requires that when a vehicle is subjected to an 80 mm drop, the sprung mass frequency must not be greater than 2.0 Hz and that the damping ratio ( $D_{1,2}$ ) must be greater than 20 per cent of critical. (The 80 mm drop height was chosen for the Directive to impose dynamic loads of  $\pm 50$  per cent as would be expected on poor roads.) The damping ratio can be resolved by measuring the successive peaks of the vehicle wheel load or body displacement responses (Figure IV.28) immediately after the event and then applying the values to the standard damping ratio equation below.

**Figure IV.28. Successive peaks of a damped transient response**

$$D_{1,2} = \frac{1}{2\pi} \cdot \ln\left(\frac{A_1}{A_2}\right)$$

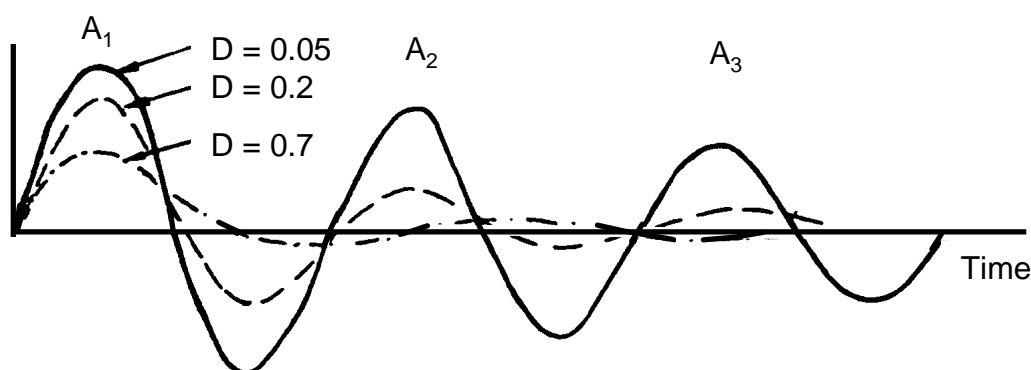

The axle drop tests resulted in the excitation of the unsprung mass, but at times the first cycle contained substantial dynamics from the unsprung mass. In some cases the first peak was not distinguishable and therefore could not be analysed with any degree of confidence. To maximise the potential for comparative analysis, the damping was also calculated using the second and third peaks as well as the third and fourth peaks from the force response curve.

$$D_{2,3} = \frac{1}{2\pi} \cdot \ln\left(\frac{A_2}{A_3}\right)$$

$$D_{3,4} = \frac{1}{2\pi} \cdot \ln\left(\frac{A_3}{A_4}\right)$$

The results given in Tables IV.4 to IV.7 and Figures IV.29 to IV.32 indicate that the damping value determined by the drop test is dependent on drop height and the response peaks chosen for the analysis. In general, the damping ratio decreases with increased drop height. The damping ratio of the air suspension increases as successive response peaks are used to calculate damping. Overall, the drop test did provide a means for determining the damping ratio, although there are some variations in the results. Dropping the axles simultaneously through a vertical distance of 80 mm is considered to be a valid test for compliance with Directive 92/7/EEC.

Air suspension

The results of the air suspension tests (Figure IV.29 and Table IV.4) show a clear linear relationship between the damping ratio and drop height for drop heights between 40 and 120 mm. A 20 mm increase in drop height results in a 19 per cent decrease in damping ratio. This relationship changes, however, for drop heights greater than 80 mm. The findings also show that the damping ratio changes depending on the successive peaks used for calculation. Analysing the third and fourth peaks of the response curve yields a damping ratio that is 29 per cent greater than the value found when calculating the second and third peaks. When tested without dampers (Table IV.5 and Figure IV.30), the damping ratio was less sensitive to drop height and to calculations using successive response peaks. The average sprung mass frequency for the air suspension with dampers was 1.53 Hz. Without dampers, the sprung mass frequency dropped to 1.49 Hz. The suspension damping was found to be 7 per cent, which is substantially below the minimum target value of 20 per cent. The dampers used on this suspension were in working order, although they were installed at a large angle of inclination which substantially reduces their effectiveness.

**Table IV.4. Simultaneous axle drop for air suspension**

Drop height (mm)	Nat. freq. Hz	Damping (percentage of critical)		
		D <sub>1,2</sub>	D <sub>2,3</sub>	D <sub>3,4</sub>
40	1.60	n.d	10.6	12.2
60	1.52	n.d	8.9	10.7
80	1.51	n.d	7.2	9.3
100	1.51	n.d	6.6	8.0
120	1.51	n.d	8.0	7.0

Note: n.d = not distinguishable

Source: NRC

**Table IV.5. Simultaneous axle drop for air suspension (no dampers)**

Drop height (mm)	Nat. freq. Hz	Damping (percentage of critical)		
		D <sub>1,2</sub>	D <sub>2,3</sub>	D <sub>3,4</sub>
40	1.48	2.0	1.7	1.6
60	1.49	1.9	1.5	1.4
80	1.49	1.1	1.1	1.3
100	1.49	1.6	1.4	1.3
120	n.d	n.d	n.d	n.d

Note n.d = not distinguishable

Source: NRC

**Figure IV.29. Damping ratio of an air suspension: simultaneous axle drop**

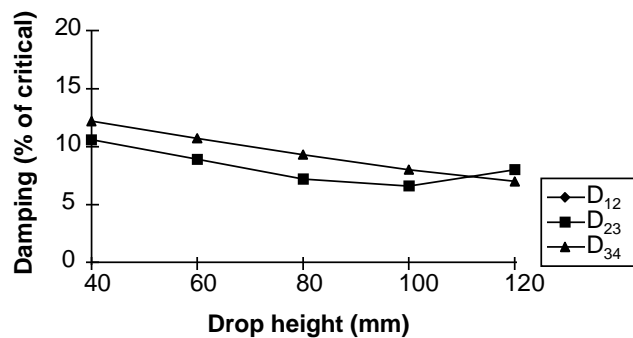

**Figure IV.30. Damping ratio of an air suspension (without dampers): simultaneous axle drop**

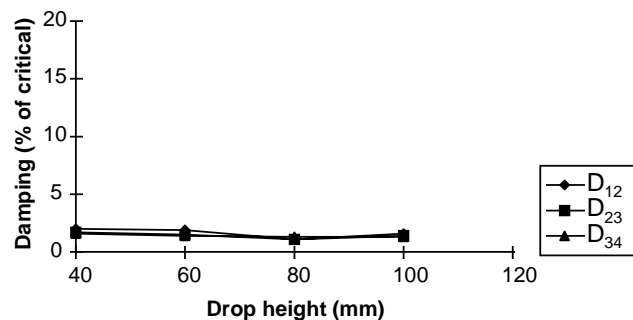

Steel suspension

The results of the steel suspension drop test, shown in Table IV.6 and Figure IV.31, are not as consistent as the air suspension tests. Drop heights in excess of 80 mm produced vehicle response signals that were not distinguishable and therefore are not included in the table or graph. The damping of the steel suspension is generally less sensitive to drop height than the air suspension. However, the steel leaf suspension is more sensitive to the response peaks chosen for the analysis than the air suspension. Both of these findings are consistent with the characteristics of Coulomb damping. The steel spring suspension was not equipped with viscous dampers. The average sprung mass frequency for the steel suspension was 3.19 Hz.

**Table IV.6. Simultaneous axle drop for steel suspension**

Drop height (mm)	Nat. freq. Hz	Damping (percentage of critical)		
		D <sub>1,2</sub>	D <sub>2,3</sub>	D <sub>3,4</sub>
40	3.23	10.0	7.2	4.7
60	3.19	9.5	9.2	4.9
80	3.16	8.3	10.2	7.4
100	n.d	n.d	n.d	n.d
120	n.d	n.d	n.d	n.d

Note n.d = not distinguishable

**Figure IV.31. Damping ratio of a steel suspension: simultaneous axle drop**

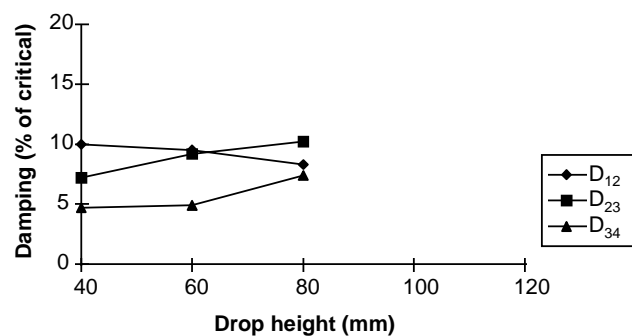

Source: NRC

Rubber suspension

The results of the rubber suspension tests shown in Table IV.7 and Figure IV.32 were very consistent. As with the other suspensions, increased drop height yielded lower damping ratios. There was little difference in the damping ratio determined by successive response peaks. Drop heights greater than 80 mm produced results that were indistinguishable. The average sprung mass frequency for the rubber suspension was 2.43 Hz.

Summary of drop tests

The results of the experiments show that simultaneous axle drop tests provide a clear separation between mechanical and air suspensions with regard to sprung mass frequency and damping. This test also clearly indicates that, due to system non-linearities, damper performance is related to drop height. The EC drop height of 80 mm was found to give reliable results. Adherence to a common drop height is imperative if accurate comparisons of suspension performance are to be achieved.

The air suspension did not meet the 20 per cent damping requirement as specified by the Directive 92/7/EEC. The most probable reason for this failure was poor damper location and orientation. This finding gives evidence that not all air suspensions meet the EC Directive and that in the future, all suspensions should be evaluated irrespective of their generic category.

**Table IV.7. Simultaneous axle drop for rubber suspension**

Drop height (mm)	Nat. freq. Hz	Damping (percentage of critical)		
		D <sub>1,2</sub>	D <sub>2,3</sub>	D <sub>3,4</sub>
40	2.49	n/r	5.1	4.8
60	2.44	4.6	3.8	4.2
80	2.36	2.6	2.6	3.8
100	n.d	n.d	n.d	n.d
120	n.d	n.d	n.d	n.d

Note: n.d = not distinguishable

Source: NRC

**Figure IV.32. Damping ratio of a rubber suspension: simultaneous axle drop**

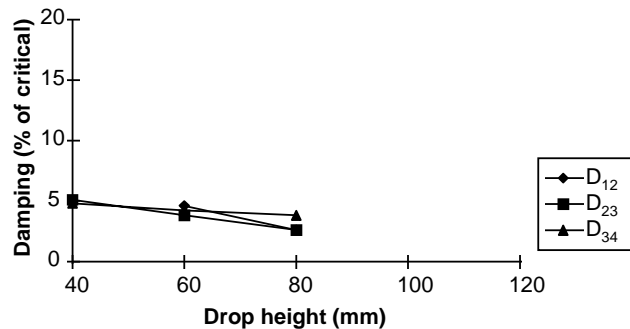

Simulated road profiles

A series of experiments were conducted using the road simulator to replicate wave forms common to roadways. Three “actual” road sections representing roads of good, average, and poor unevenness were selected to serve as a standard road set for the DIVINE Project. Vertical profiles of the wheel paths were measured and the International Roughness Index (IRI) for the sections was calculated as shown in Table IV.8.

**Table IV.8. International Roughness Index for DIVINE road profiles**

Road surface unevenness	International Roughness Index
“NRC good”	0.97
“NRC average”	2.23
“NRC poor”	4.46

Source: NRC

The profiles were used to drive the simulator in order to assess the response of the three suspensions at different speeds. The profiles were created by measuring the vertical profile of left and right wheel paths. To eliminate roll input to the vehicle while on the shaker, the left wheel path profile was used to drive both the left and right actuators. Road simulator tests were conducted for the three profiles using three different suspensions fitted to the standard test trailer. The DLCs were calculated and plotted to permit comparison.

A second set of similar experiments was conducted using a “virtual” road profile representing generic good, average and poor roads. The character of the virtual road profile was defined in terms of the slope of the power spectral density (PSD). A slope of -2 on a displacement spectral density (m<sup>3</sup>/cycle) versus wave-number (cycles/m) was found to represent a strong first order approximation of the actual road profiles and also produced constant power as a function of frequency. The magnitude of the virtual

road profile was adjusted to approximate the good, average and poor unevenness of the DIVINE road profiles. Evaluated at the wave-number of  $1/(2\pi)$ , the magnitudes used are listed in Table IV.9.

**Table IV.9. Magnitude of virtual road profiles and approximate IRI equivalency**

Road surface unevenness	International Roughness Index	Displacement spectral density ( $m^3/cycle$ )
“NRC good”	0.97	$2.7 \times 10^{-7}$
“NRC average”	2.23	$4.5 \times 10^{-6}$
“NRC poor”	4.46	$2.7 \times 10^{-5}$

Source: NRC

Exciting suspensions using the DIVINE or virtual road profiles provides a comprehensive means for suspension assessment. However, both of these tests can only be performed on a full-scale shaker, which is limiting. Because of the high capital costs of shaker systems, this test would not be a practical means of assessing suspension road-friendliness compliance at intervals during the life of the suspension.

#### Sinusoidal frequency sweep

The in-phase sinusoidal excitation was conducted for a range of constant amplitudes from DC to 20 Hz. The constant single amplitude displacements used were: 1, 2, 3, 4, 6 and 8 mm. The results clearly show that a very small constant amplitude sine forcing function can cause significant suspension response at the sprung and unsprung mass frequencies. The effects of suspension damping variations is illustrated well at high and low frequencies as shown in Figures IV.33 and IV.34.

This method shows strong promise as a means for assessing suspension road-friendliness as well as a practical means for assessing damper condition. Since the test is based upon constant amplitude input, it is practical for a relatively simple mechanical device to be developed to generate the driving function.

The in-phase constant amplitude sinusoidal sweep excitation test has proven to be most effective at distinguishing suspension response at both the sprung mass and unsprung mass frequencies, as shown in Figure IV.35. Note that in Figure IV.35, the bars labelled low frequency represent the sprung mass frequencies and the bars labelled high frequency represent peak unsprung mass frequency for the air, steel and rubber suspensions. This method clearly separates the suspensions by type and also permits the calculation of the damping coefficient. Forcing function amplitudes of 1 or 2 mm produced excellent results. Displacements greater than 2 mm generated excessive vehicle response, particularly at the unsprung mass frequency.

While the constant amplitude sinusoidal sweep excitation shows strong promise as a suspension test, work is still needed to define appropriate criteria for suspension road-friendliness using this test. A comprehensive modelling and test programme will be required to establish the test protocol and criteria.

**Figure IV.33. Constant 1 mm displacement sinusoidal input: air suspension with dampers -- both axles excited in phase**

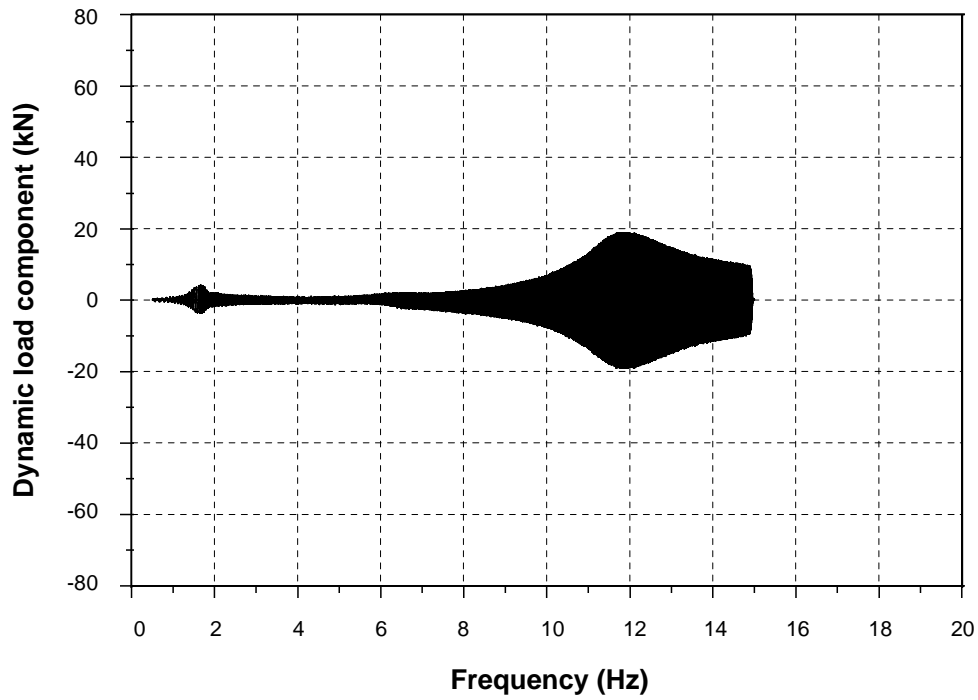

Source: NRC

**Figure IV.34. Constant 1 mm displacement sinusoidal input: air suspension without dampers -- both axles excited in phase**

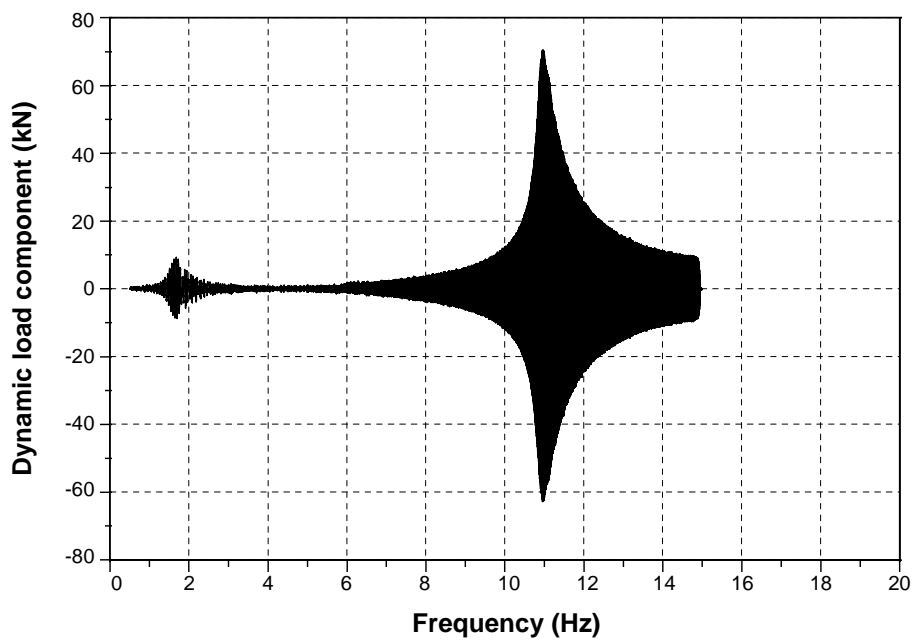

Source: NRC

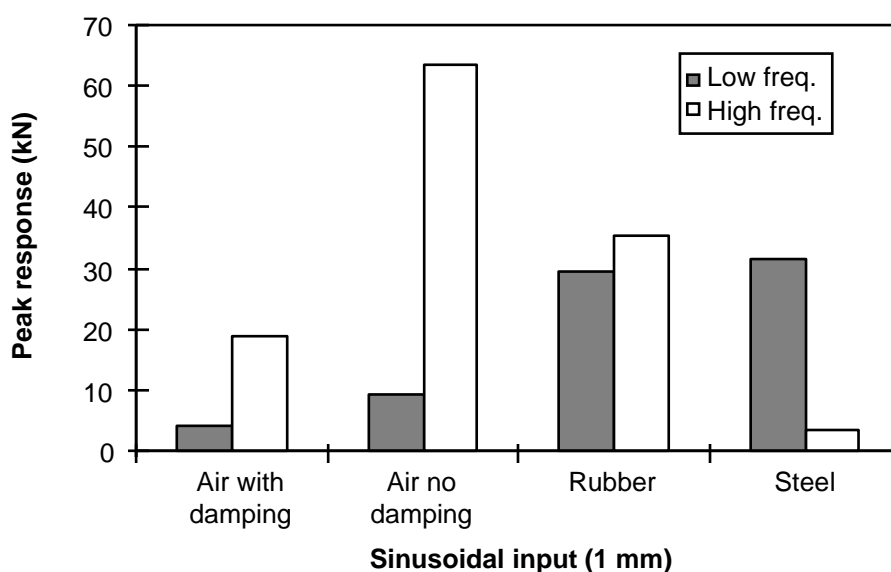
**Figure IV.35. Peak frequencies at sprung and unsprung mass frequencies for various suspensions**

Source: NRC

### IV.3.3 Evaluation of computer models

#### Description of task

The computer simulation task was a means to determine the ability of various computer models to predict dynamic wheel loads and vehicle vertical response due to a defined input. The exercise was coordinated by the Road-Vehicles Research Institute of the Netherlands Organisation for Applied Scientific Research (TNO-WT) working under the auspices of the DIVINE joint research programme (Hoogvelt and Ruijs, 1997). Owners of computer models were invited to a blind trial of their model.

All participants were given:

- Identical vehicle parameters and road profile input data from instrumented vehicle tests.
- Specifications governing the format for vehicle data, road data and delivery of results.
- Measured response and dynamic load time histories of the experiments. This was provided after the results were delivered. The model owners were then allowed to tune their model and submit a second set of simulated dynamic loads.

A smooth road profile was chosen to validate the models because small excitations would distinguish differences between linear and non-linear models by testing their ability to simulate the stick-slip behaviour of the steel suspension. The frequency range of interest was between 0.5 and 15 Hz.

The TRL two axle instrumented vehicle was selected as the candidate vehicle for the computer simulation task. Vehicle speeds at which validation data existed were 65, 75 and 85 km/h. Spring and

damper characteristics and the key mechanical attributes of the truck were measured and supplied to the package owners.

### *Description of models*

The following six organisations responded to the invitation and participated in the modelling and simulation task:

- Pennsylvania Transportation Institute (United States);
- Scania Truck and Bus (Sweden);
- TNO Road-Vehicles Research Institute (Netherlands);
- Roaduser Research Pty Ltd. (Australia);
- Federal Highway Administration (United States);
- Osaka University (Japan).

Pennsylvania Transportation Institute (PENNSYLVANIA) submitted a simplified linear model using PCMATLAB. The mathematical model represents a linear quarter-truck model and consisted of four linear state equations.

Scania Truck developed a model using the general purpose, multi-body simulation program DADS (Dynamic Analysis & Design System). It is a three-dimensional assembly of three rigid bodies (sprung mass, front and rear axles), four leaf springs, four dampers and six tyre elements. An in-house Scania leaf spring model with estimated parameter values was used.

TNO Road-Vehicles Research Institute developed a model using the program PARADYME, a dedicated layer of modelling macros related to the TNO in-house multi-body simulation program BAMMS. BAMMS is a symbolic multi-body program that generates FORTRAN 77 code for each model. The PARADYME shell offers users a flexible simulation environment based on a database principle. All model parameters are stored in a database of ASCII data files in a strict hierarchical structure. This model contains two rigid axle components that differ in the steering parameter as well as the stiffness, damping and geometry parameters. Each suspension model is described by a separate parameter file.

Roaduser Research developed a two axle Infrastructure Interactive Model as one in the series of Roaduser AUTOSIM Truck Engineering Dynamics (RATED) models that predict the dynamic behaviour of various heavy vehicle configurations ranging from two-axle rigid trucks to 28-axle road trains. The RATED models were developed using the AUTOSIM multi-body simulation code and were validated by field testing. The RATED model of the TRL truck included the UMTRI leaf spring model.

The Federal Highway Administration (FHWA) Truck Pavement Interaction (TPI) group developed a modelling and simulation tool VSIM3D. The software has been validated against experimental data from shaker table testing. The software is comprehensive enough to simulate various vehicles and roads allowing for easy modification. On-going efforts are being made to validate the model with test road data.

The Osaka University used a seven degree-of-freedom model (7-DOF) initially designed to analyse the dynamic response of bridges under moving vehicles. It is used as a stand-alone model.

#### *Results of modelling exercise*

Three characteristics were used to validate and/or compare the models:

1. the DLC values predicted by the models were compared with DLC values calculated from actual wheel load measurements;
2. the cumulative distribution function of the wheel load was used to analyse the dynamic components;
3. the harmonic content of the wheel load was used to analyse the frequency range of the different models.

One of the six participants (TNO) responded to the proposed model-tuning option of performing a second simulation run with knowledge of the measured wheel loads. In this second try, the only part that was changed were the suspension characteristics of the UMTRI suspension model for leaf springs (see Figure IV.36). The change improved the model performance considerably and demonstrated that it is essential to have a realistic spring model to simulate vehicle behaviour (Hoogvelt and Ruijs, 1997).

**Figure IV.36. Spring characteristic of rear axle**

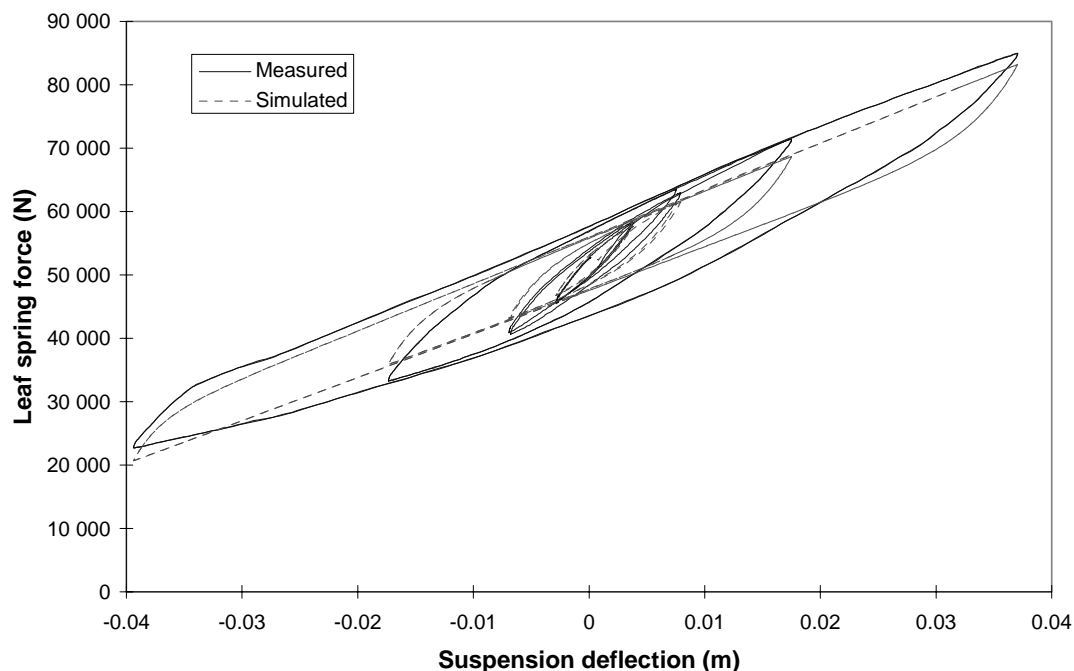

Source: TNO

As a result of the modelling exercise it appears that the cumulative histogram function is the best function to analyse and validate the models (see Figures IV.37 and IV.38). The harmonic content gives

good qualitative information on the models (see Figure IV.38). The DLC value has a limited role in validating models.

**Figure IV.37. Cumulative distribution function of simulated front left wheel load at 65 km/h**

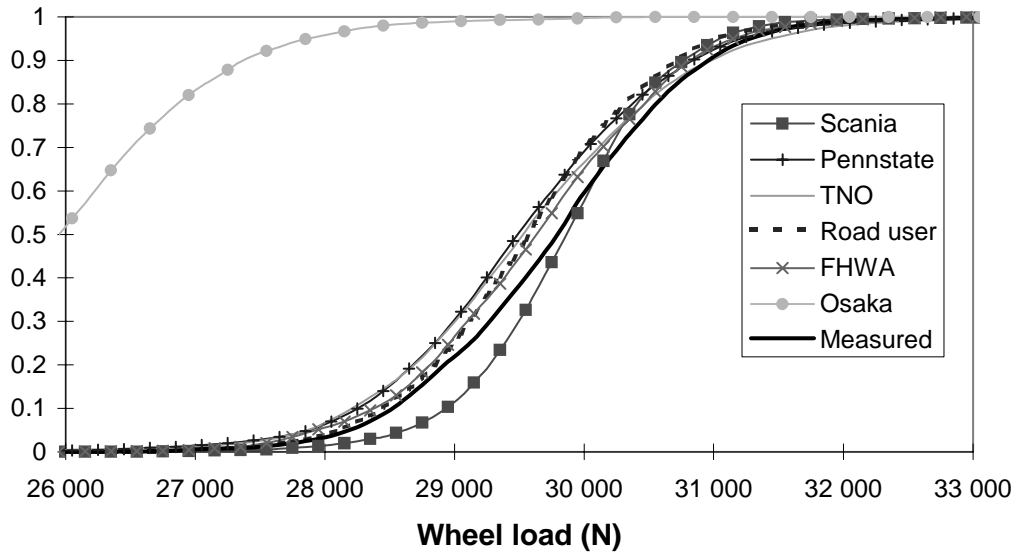

Source: TNO

**Figure IV.38. Cumulative distribution function of simulated rear left wheel load at 85 km/h**

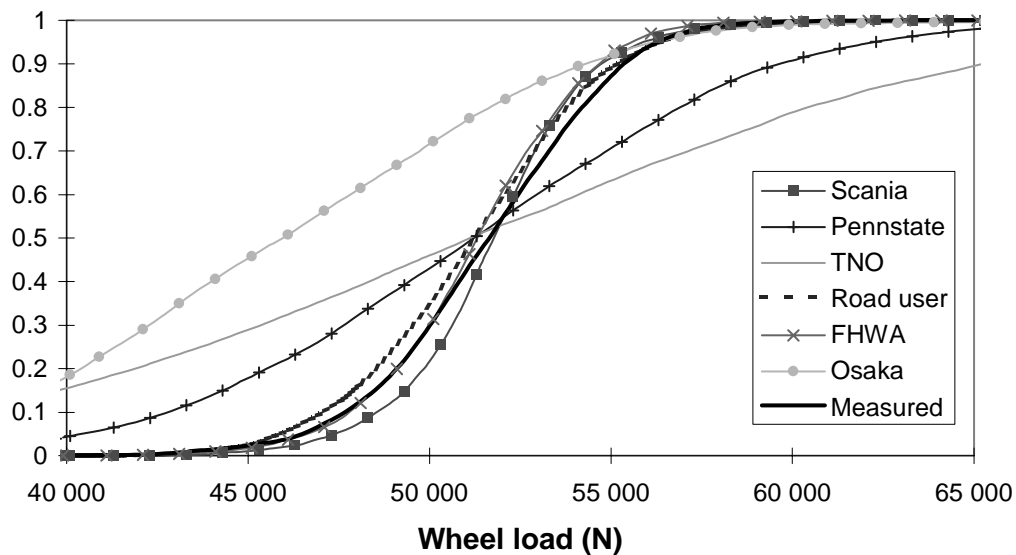

Source: TNO

Some computer simulations of dynamic wheel loads are capable of calculating these loads to an accuracy of between 5 and 10 per cent. It is essential for these models to accurately represent the non-linear characteristics of the suspension, particularly the Coulomb friction that causes stick-slip motion

of the suspension elements (see Figure IV.36). The models that are capable of simulating the dynamic wheel loads to the above-mentioned accuracy are similarly able to predict the actual DLC values (see Figure IV.39 and Table IV.10).

**Figure IV.39. DLC values of simulated wheel loads at 85 km/h**

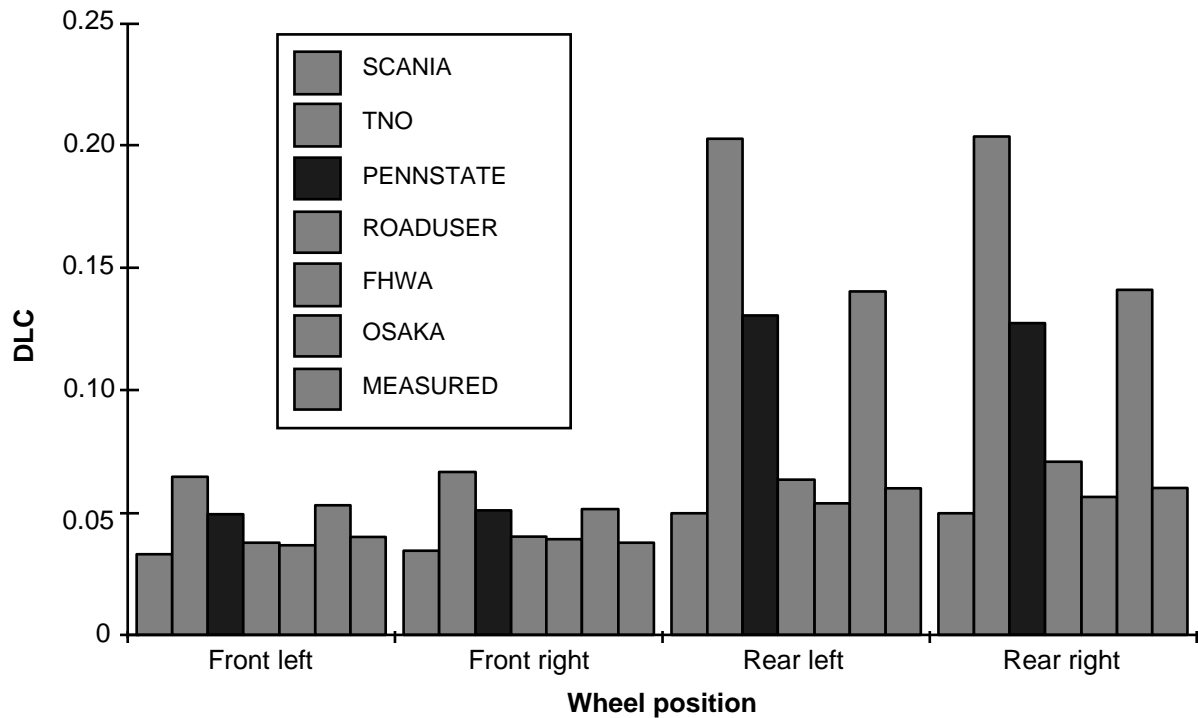

Source: TNO

**Table IV.10. DLC values of simulated wheel loads**

Location	Speed (km/h)	Scania	TNO	Pennstate	Roaduser	FHWA	Osaka	Measured
Front left	65	0.0257	0.0385	0.0361	0.0313	0.0333	0.0466	0.0328
	75	0.0309	0.0486	0.0452	0.0372	0.0354	0.0531	0.0394
	85	0.0331	0.0647	0.0492	0.0376	0.0364	0.0530	0.0399
Front right	65	0.0267	0.0392	0.0373	0.0342	0.0358	0.0430	0.0337
	75	0.0318	0.0483	0.0459	0.0398	0.0380	0.0501	0.0371
	85	0.0344	0.0669	0.0510	0.0402	0.0391	0.0513	0.0377
Rear left	65	0.0308	0.0956	0.0825	0.0539	0.0434	0.0881	0.0511
	75	0.0432	0.1576	0.1228	0.0596	0.0502	0.1325	0.0572
	85	0.0497	0.2027	0.1304	0.0634	0.0540	0.1404	0.0598
Rear right	65	0.0314	0.0978	0.0839	0.0606	0.0452	0.0911	0.0531
	75	0.0434	0.1579	0.1230	0.0651	0.0522	0.1316	0.0609
	85	0.0496	0.2037	0.1277	0.0706	0.0564	0.1410	0.0601

Source: TNO

None of the models intended to simulate the dynamic loads due to wheel imbalance; this type of dynamic load can greatly influence the amplitude of axle hop frequency, when the frequency of the wheel imbalance mode exceeds the axle hop frequency.

The RATED model and the VESYM3D were found to be the most accurate models in estimating the wheel loads of the truck for all circumstances. The Scania model was third in ranking.

#### IV.3.4 Suspension properties for road-friendliness

Spring stiffness and damping characteristics are the two fundamental properties of heavy truck suspensions that affect suspension road-friendliness. A suspension having low spring stiffness, free from Coulomb damping (inter-leaf friction) and combined with an appropriate level of viscous damping, will result in the desirable outcome of low dynamic loads at the sprung mass frequency.

To determine the appropriate limit for sprung mass frequency and the minimum viscous damping required to qualify as “road-friendly”, the relationship between sprung mass frequency and viscous damping with respect to dynamic load coefficient (DLC) was studied by computer simulation. The RATED model was used to characterise various generic suspensions on a fully loaded two-axle vehicle.

##### *Sprung mass frequency*

Figure IV.40 shows that a strong relationship exists between the sprung mass frequency and DLC. Table IV.11 lists the suspension frequency and damping variations examined by simulation. As the sprung mass frequency of a suspension increases, the DLC increases. The rate at which the DLC increases, as a function of the mass frequency, depends on road roughness. The more uneven the road, the greater the increase in DLC.

**Figure IV.40. The relationship between sprung frequency and DLC (damping 20 per cent)**

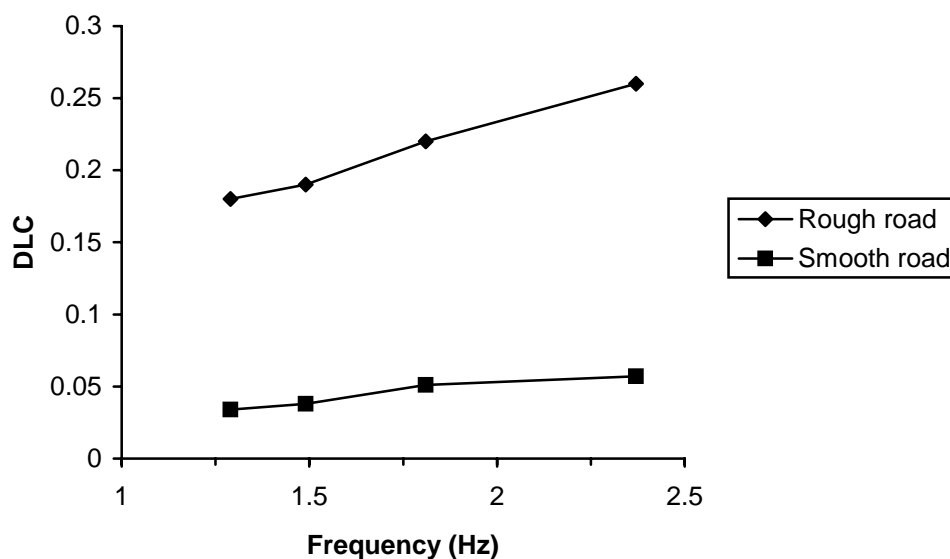

Source: NRC

**Table IV.11. Sprung mass frequency and damping variables used for mechanical and air suspensions**

Sprung mass frequency Hz		Damping percentage of critical	
Mechanical	Air	Mechanical	Air
2.00	1.33	20	7 - 30
2.17	1.50	17	5 - 27
2.63	2.00	11	7 - 27
2.94	2.50	5.4	5 - 9

Source: NRC

The simulation study also showed that the relationship between sprung mass frequency and DLC is affected by the amount of viscous damping present. The more viscous damping that is present in the suspension, the lower will be the rate of increase in DLC as a function of sprung mass frequency.

The Directive 92/7/EEC requires that a suspension with dynamic loading performance equivalent to air suspension have a sprung mass frequency of not greater than 2.0 Hz. It is clear from Figure IV.40 that a reduction of the sprung mass frequency requirement from 2.0 Hz to 1.5 Hz achieves a net improvement in suspension performance of approximately 24 per cent (assuming a rough road condition). Given that current air suspensions generally have sprung mass frequencies below 1.5 Hz, reducing the maximum value of sprung mass frequency from 2.0 to 1.5 Hz will not impose undue hardship on the industry. It would, however, significantly reduce the ability of many steel spring suspensions to be regarded as road-friendly. Nevertheless, reducing the sprung mass frequency requirement to 1.5 Hz will ensure that the maximum benefits of suspension road-friendliness will be achieved within practical limits.

#### *Viscous damping*

As shown in Figure IV.41, viscous damping has a strong influence on DLC. The system response is most sensitive to damping -- i.e. DLC increases more rapidly with decreased damping -- for values below 15 per cent of critical. Based on this finding it appears that the minimum requirement of 20 per cent damping stated in Directive 92/7/EEC is appropriate. However, it should be noted that damping greater than 20 per cent yields diminishing benefits, thus implying that damping values significantly higher than 20 per cent are not necessarily useful.

Viscous dampers wear over time and must be serviced or replaced. The rate of wear is often gradual, resulting in a reduction of damping performance. It is therefore important to consider a serviceability limit for suspension damping. It is recommended that dampers be serviced or replaced once the suspension damping falls below 20 per cent, although significant reduction in road-friendliness may not occur until damping falls below 10 - 15 per cent.

#### *Coulomb damping*

The presence of Coulomb damping (sliding friction) has been found to adversely effect suspension performance. The Directive 92/7/EEC requires that the Coulomb damping ratio not exceed 50 per cent of the viscous damping. Coulomb damping is measured by performing the drop test with the

viscous dampers removed. This requirement is an important element in defining the road-friendly performance of mechanical suspensions.

**Figure IV.41. The relationship between viscous damping and DLC**

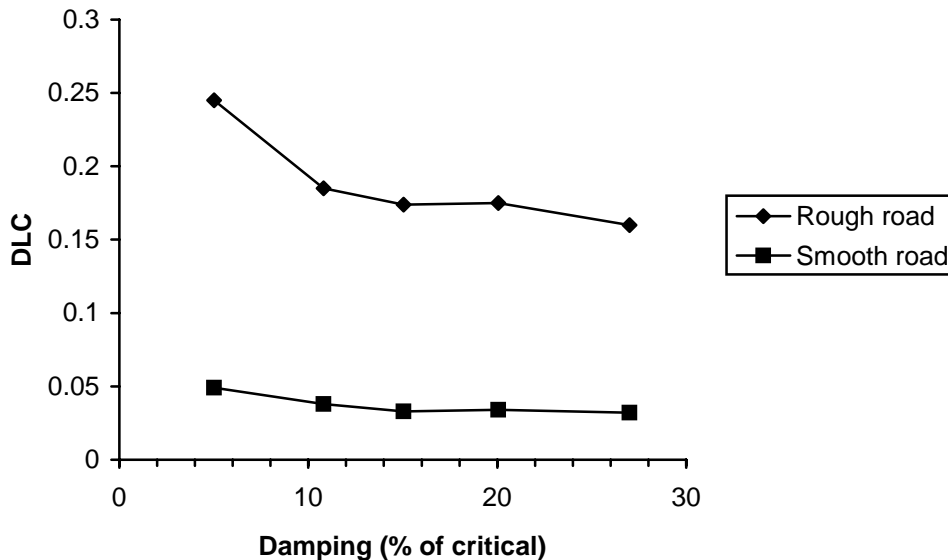

Source: NRC

#### *Suspension load equalisation*

Suspension load equalisation expresses the ability of the suspension to maintain equal mean axle loads on all axles in an axle group (tandem or tridem). Load equalisation within tandem and tridem axle groups is a very important performance attribute because those systems that equalise axle loads poorly impose consistently higher road loading than those that equalise them well. This suspension characteristic has implications in vehicle design and operation. For example, semi trailers are coupled to different power units with different coupling heights resulting in trailer pitch angle variations. Variations in pitch angle can result in changes in trailer axle load equalisation. The effects of such variations can be minimised by establishing performance standards governing suspension load equalisation performance.

Load equalisation may be evaluated on the basis of average load variation per unit of relative vertical axle displacement (for example, 100 mm of travel). Figure IV.42 shows the load equalisation characteristics of both a steel and air tandem axle suspension and a recommended limit for axle load equalisation performance. This figure does not, however, include any offset due to the axle load. To qualify as a road-friendly tandem suspension, it is recommended that differential axle load variation must be no greater than 0.3 kN/mm based on a 9 tonne axle load.

**Figure IV.42. Axle load equalisation (stationary conditions) by suspension type (tandem axle trailing arm air suspension and tandem axle steel spring suspension)**

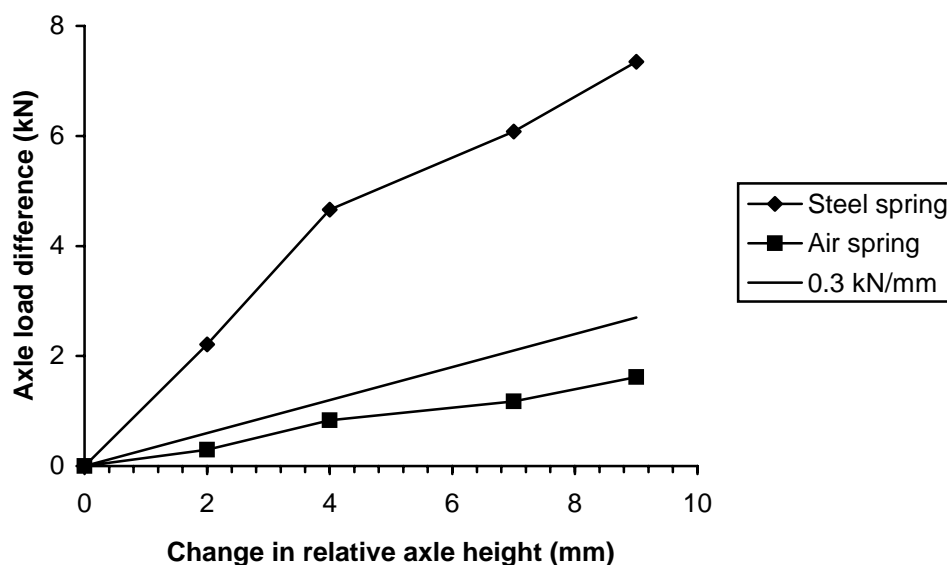

Source: NRC

#### IV.3.5 Evaluating suspension performance

Evaluation of suspensions as independent vehicle sub-systems offers a practical solution to the problem of testing road-friendliness.

Treating the suspension as a sub-system allows for low-cost, simplified test methods to be implemented with high-quality results. The findings from the shaker experiments conducted as part of the DIVINE Project proved that hydraulic shaker systems are an effective means of assessing suspension performance provided that all axles of a given vehicle are excited at the same time by the shaker. This will produce vertical vehicle response with characteristics similar to the over-the-road experience.

Less complex options for exciting and evaluating suspension assemblies have also proven useful. A test concept emerged from the experiments whereby the suspension can be excited by a constant amplitude sinusoidal displacement function that is swept through a given frequency range. The excitation can be achieved with a shaker or, alternatively, a relatively simple and cheap mechanical mechanism. This method is able to determine both the sprung and unsprung mass frequencies as well as damper function. A similar test is used in European countries to determine the road-worthiness of passenger car suspensions. Suspension sprung mass and unsprung mass frequencies as well as viscous and Coulomb damping can be determined by this method. More work is required before this method is ready for implementation with heavy vehicles.

The simultaneous 80 mm suspension drop test has proven to be a useful means of assessing suspension road-friendliness for multiple axle load sharing suspensions. It is recommended that a suspension be considered road-friendly if the natural frequency does not exceed 1.5 Hz and the damping is at least 20 per cent of critical. For mechanical suspensions presented as road-friendly candidates, it is recommended that the Coulomb damping ratio does not exceed 50 per cent of the viscous damping.

## BIBLIOGRAPHY

- AURELL, J. (1991), "On the Influence of Different Suspension Parameters of Commercial Vehicles on Dynamic Wheel Loads", *Proceedings of the Inst. Mech. Eng. Conference on Dynamic Road Loading*, London.
- BONAQUIST, R. (1992), "An Assessment of the Increased Damage Potential of Wide Based Single Tires", *Proceedings of the 7th International Conference on Asphalt Pavements*, Vol. 3. ISAP.
- CANTIENI, R. and R. HEYWOOD (1998), "Dynamic Load Testing of Road Bridges in Switzerland and Australia", EMPA Draft Report, Swiss Federal Laboratories for Materials Testing and Research, Dübendorf, Switzerland, and Queensland University of Technology, Brisbane, Australia.
- COLE, D. J. and D. CEBON, (1994), *Truck Suspension Design to Minimize Road Damage*, CUED/C-MECH/TR64, Cambridge.
- COST 323, (1997), *European Specification on Weigh-in-motion of Road Vehicles*, draft 2.2, EUCO-COST/323/5/1997, Cost Transport, EC/DGVII, Brussels.
- COUNCIL OF THE EUROPEAN COMMUNITIES (1992), Council Directive 92/7/EC, Brussels.
- HOOGVELT, R. B. J. and P. A. J. RUIS (1997), *OECD - IR6 DIVINE Element 4. Computer Simulation of Heavy Vehicle Dynamic Wheel Loads*, TNO Report 97.OR.VD.016.1/RH/PR, TNO, Delft, The Netherlands.
- HUHTALA, M., PIHLAJAMÄKI, J. and P. HALONEN (1997), "Pavement Response due to Dynamic Axle Loads", *Proceedings of the Eighth International Conference on Asphalt Pavements*, Volume I pp 471-485, University of Washington, Seattle.
- HUHTALA, M., PIHLAJAMÄKI, J. and P. HALONEN (1997), *Pavement Response due to Dynamic Loads*, Technical Research Centre of Finland, Espoo.
- INTERNATIONAL ORGANIZATION FOR STANDARDIZATION (ISO) (1995), *Mechanical Vibration - Road Surface Profiles - Reporting of Measured Data*, ISO/DIS 8608:1995(E), Geneva.
- JACOB, B. AND V. DOLCEMASCOLO (1997), *Répétabilité spatiale des forces d'impact sur une chaussée*, Laboratoire Central des Ponts et Chaussées, Paris.
- KENIS, W., GEORGE, D. AND J. HAMMOUDA (1997), *Pavement Primary Response to Dynamic Loading*, Report no. FHWA-RD-073, Federal Highways Administration, Washington, DC.
- KENIS, W. AND W. WANG (1997), *Analysis of Pavement Structural Variability*, Report No. FHWA-RD-072, Federal Highways Administration, Washington, DC.

- MAGNUSSON, G., CARLSSON, H.E. and E. OHLSSON (1984), *The Influence of Heavy Vehicles' Springing Characteristics and Tyre Equipment on the Deterioration of the Road*, VTI Report 270.
- OECD ROAD TRANSPORT RESEARCH (1992), *Dynamic Loading of Pavements*, OECD, Paris.
- PIDWERBESKY, B. AND J. DE PONT (1995), "Results of CAPTIF Pavement Testing and Analysis", *Proceedings of the Dynamic Loading of Heavy Vehicles and Road Wear Mid-term Seminar*, Sydney. Austroads.
- RAKHEJA, S. and J. H. F. WOODROOFFE (1994), *Role of Suspension Damping in Enhancement of Road-friendliness of Heavy Vehicles*, Engineering Foundation Conf., Noordwijkerhout NL.
- SHARP, K. G. and M. A. MOFFATT (1996), *Analysis of Performance Data Collected during Trafficking of Test Pavement by CAPTIF: Element 1 of OECD IR6 Project*, ARRB Transport Research Contract Report CR RI905/3, April.
- STEVEN, B. D., FUSSELL, A. W. and B. D. PIDWERBESKY (1996a), *DIVINE Element 1 construction report*, Civil Engineering Research Report 96-8, University of Canterbury, Christchurch, New Zealand.
- STEVEN, B. D., FUSSELL, A. W. and B. D. PIDWERBESKY (1996b), *DIVINE Element 1 pavement post-mortem report*, Civil Engineering Research Report 96-9, University of Canterbury, Christchurch, New Zealand.
- SWEATMAN, P. F. (1994), *Implementation of requirements for road-friendliness of heavy vehicles*, Roaduser Research 92-93-46.
- WOODROOFFE, J. H. F. (1997), *Heavy Truck Suspensions: Methods for Evaluating Road-friendliness*, NRC & Roaduser Research, Ottawa.

## **CHAPTER V. IMPROVING THE VEHICLE-INFRASTRUCTURE SYSTEM: IMPLICATIONS OF THE DIVINE RESEARCH**

The research carried out under the DIVINE Project provides the scientific basis for a new approach to the management of trucks and roads as a transportation system and the results point the way to new initiatives in the design, construction and maintenance of pavements, bridges and vehicles. This chapter suggests ways in which the DIVINE findings may be applied to each of these sectors. An even greater challenge will be to deal with the significant interactions which occur in the vehicle-infrastructure system. While the results of the DIVINE Project will create an awareness of these interactions, it is likely that further research will be needed to find better ways of managing the total system. This chapter therefore also suggests strategic directions for research in the vehicle-infrastructure system.

One of the strongest themes arising from the DIVINE Project is the continued need for a multi-disciplinary approach to vehicle-infrastructure issues. From now on, pavement, bridge and vehicle sector technologies should take into account impacts on all other sectors. Similarly, future research must truly cross the boundaries of the traditional engineering disciplines involved.

The remainder of this chapter deals separately with the different components of the system, and concludes by stating the research needs identified by the DIVINE Project in each of these areas.

### **V.1 Pavements**

For a variety of reasons, the science of pavement engineering is, in global terms, less well-developed than that of bridges and vehicles. Given the many unresolved questions in pavement engineering performance, it will not be easy to include a further set of complex dynamic factors in methods for the design and maintenance of pavements. However, if this challenge can be met, the rate of progress in resolving pavement research questions is likely to be greatly accelerated.

In considering the physical interaction between the vehicle and the performance of the pavement on which it is travelling, a number of characteristics of the pavement clearly come into play. These include, for example, the longitudinal profile of the road which influences the dynamic loads generated, the current structural condition of the pavement which determines how the pavement responds to the imposed dynamic loads, and conditions at the tyre-road interface which affect the transmission of the dynamic load to the pavement structure. It is clear, therefore, that the degree of interaction will change as any or all of these parameters change during the life of the pavement.

The results of this interaction are manifested in the long-term performance of the pavement and, in this regard, various means are available to measure and monitor pavement performance. To a lesser extent, the physical interaction of the vehicle and pavement are taken into account in the design of the pavement and various techniques, including mechanistic design and accelerated pavement testing, are available to assist in this process.

Important decisions also need to be made concerning allowable vehicle weight limits, attribution of costs to truck use and maintenance intervention. This requires the support of appropriate concepts of pavement life, consumption of the available pavement life and measures of pavement wear or damage.

### ***V.1.1 Pavement response to vehicles***

In terms of pavement response to vehicles, the DIVINE Project has established several important facts that have important implications for the pavement component of the system. For instance, the work on pavement primary response in Element 2 confirmed that for relatively thick pavements (160 mm of bituminous material), horizontal strains measured at the bottom of the asphaltic layer were almost directly proportional to the dynamic wheel force. A 10 per cent increase in dynamic wheel load, for example, produced a 7 to 12 per cent increase in strain. Given the accepted relationship(s) between strain and pavement damage, this implies significantly increased pavement wear under traffic which consistently applies such loads.

The design of these thick pavements should therefore take account of the potential increase in damage. As a first step, it may be necessary to adopt a relatively coarse approach to account for this damage in the pavement design process. In order to refine the approach, further research is recommended to determine how to estimate the dynamic loads arising from a fleet of vehicles with widely varying axle, wheel and suspension configurations on a deteriorating longitudinal profile.

The research effort also found that the pavement strain response to dynamic loading is not dependent on the frequency of the dynamic wheel loading. The response to high-frequency axle-hop loading is therefore the same as the response to low-frequency body-bounce loading. By contrast, a 10 per cent increase in dynamic wheel load on thin pavements produced a much lower (2 - 3 per cent) increase in strain than for thick pavements. This suggests that the load-spreading mechanisms in thin pavements are substantially different from those in thick pavements, and may be heavily dependent on conditions at the tyre-road interface. The contact stresses, for example, may contribute more strongly to the deterioration of the wearing course than do the strains generated within the pavement. At present, it seems unlikely that these effects can be taken into account in a design method for thin pavements since little is known of them. The findings from DIVINE have placed some emphasis on this problem and it is recommended that further research into these effects, using a wide range of tyre, wheel and pavement types, is undertaken in order to propose meaningful changes to current mechanistic or empirical design procedures.

DIVINE also confirmed that dynamic wheel force depends on the suspension type, the profile of the road pavement and the speed of the vehicle. The research has further quantified these effects. On reasonably smooth roads, for example, steel suspensions produced impact factors of 1.3, and air suspensions produced factors of 1.1 to 1.15 for the bogie axles of semi-trailers, although the difference was almost negligible for the single axles of rigid trucks or tractors. On rough roads, however, steel suspensions produced impact factors of 1.4 to 1.5 and air suspensions 1.2 for these bogies. Clearly, this implies that, by “controlling” longitudinal profile, there is scope to reduce dynamic impact factors for both steel and air suspensions which will, in turn, lead to improvements in life for all types of pavement. However, when the effect of suspension type is coupled with the effect of dynamic load on pavement strains, it is evident that thinner pavement constructions will be particularly at risk. Thus, the “deterioration cycle” for thinner pavements will evidently be considerably shorter than for thicker pavements, despite the fact that they have been designed for less traffic.

At the practical level, such longitudinal profile control can currently only be economically applied during pavement construction or resurfacing. The DIVINE results suggest that a basis for an economically justifiable intervention to restore longitudinal profile to an acceptable level will require considerable development and that the monitoring and control (where possible) of profiles to provide quantitative information on their deterioration related to the traffic they carry will be necessary to this development. As was noted in the results of the accelerated pavement test, the use of current international indicators of longitudinal profile may not be best suited to this purpose.

For fatigue damage, the rigid and semi-rigid pavements are much more sensitive than flexible pavements to the dynamic load increase because of the higher power in the fatigue law. The results from DIVINE do not allow the determination of an accurate threshold value -- i.e. above which some maintenance intervention is desirable -- for the longitudinal profile, but for IRI indices above 2.5 to 3 the dynamic loads increase rapidly.

The work on pavement primary response also confirmed the dependency between vehicle speed and pavement response. It was concluded that at creep speeds, the strain generated by a given wheel load is much higher than at normal traffic speeds. This may have important implications given that some regions continue to experience serious congestion on heavily-trafficked roads. This is especially relevant because localised pavement damage can be disproportionately expensive to reinstate, particularly on heavily-trafficked roads, due to the interference with the normal flow of traffic. The effects of slow-moving truck traffic on these roads may therefore need to be allowed for in their design or rehabilitation.

The spatial concentration of dynamic wheel loads is potentially very significant for all types of pavement. The DIVINE research results on spatial repeatability demonstrate the existence of this potential, but also draw attention to the fact that the phenomenon is heavily dependent on the road profile, the mix of suspensions in use on the vehicles in the traffic stream, the wheel-bases of those vehicles and the range of their speeds. In circumstances where the composition of the truck traffic flow tends to be confined to a few particular types, the risk of pavement damage from spatial repeatability will be higher. Such circumstances are increasingly frequent, particularly as the nature of heavy goods vehicles tends to be function-specific. In Europe, for example, most long-haul journeys are made by 5- or 6-axle semi-trailers, the majority of which are equipped with air suspension. While this will reduce dynamic loading, there will also be a tendency for spatial repeatability to occur.

Another finding of the DIVINE work is that dynamic axle load increments not only increase the pavement fatigue damage when spatial repeatability is present, but also for random phasing of the impact forces. This results from the non-linearity of the fatigue law for bituminous materials. Under these conditions, the main vehicle and axle vertical motions, such as body bounce and axle-hop, as well as the wheel perimeter effect -- i.e. unbalanced forces and perimeter defects -- on smooth road profiles, can increase damage by as much as 5 per cent on roads of good evenness and between 30 and 50 per cent where evenness is poor.

Better knowledge of the dynamic wheel and axle loads and their spatial repeatability may be obtained through the use of MS-WIM systems that provide impact force measurements at different locations along the pavement. Such systems could help to monitor the traffic loads and their relationship to the pavement profile deterioration. This type of monitoring is recommended.

In summary, DIVINE has shown that pavement response to vehicle dynamic loading is sufficient to warrant specific consideration in pavement design methods, but the attention required may differ depending on the thickness of the pavement being considered. In particular, more research is needed on the responses of thinner pavements and on tyre contact effects. The results from DIVINE also indicated

that the longitudinal profile of the road played a significant role in bringing about spatial repeatability and there is, therefore, a need to monitor and control longitudinal road profiles in order to determine their effect on spatial repeatability. Such monitoring will also assist in the development of an algorithm to establish limiting profiles for repeatability. Similarly, profiles need to be monitored and controlled in order to reduce the degree of dynamic loading. The IRI may provide some assistance but better algorithms and more appropriate indices may be needed. For these reasons, as well as for those noted previously, control of the longitudinal profile is highly desirable.

### ***V.1.2 Pavement design and performance***

This section of the report discusses the significance of dynamic loading for pavement design and analysis, particularly in response to the findings of the DIVINE accelerated dynamic pavement test.

#### *Pavement design tools*

One of the most significant developments in the field of pavement engineering in the past half century has been the introduction of mechanistic (or structural) pavement design methods to replace the traditional empirical methods. See Annex A for further details. Mechanistic procedures involve two steps: (i) the response model, where the response -- stresses, strains and displacements -- of a given pavement to a load is calculated; and (ii) the performance model, where the responses are input into some type of life-prediction model which is generally based on some form of a "power law".

Some of these models attempt to take account of the fact that the behaviour of pavement materials is not linear elastic but either stress dependent and/or viscoelastic. However, because of their complexity, mechanistic pavement design methods tend to be based on elastic layer models which, while more simplistic, still cater to materials characteristics such as degrees of anisotropy and multi-axle loading situations. They are also more likely to be accepted into practice, and in fact are being accepted into practice, because designers can take advantage of PC-based applications of these methods. More complicated viscoelastic and, particularly, finite element models are used as research tools. Although their introduction into current practice should be encouraged, further development is needed before they are likely to be adopted by practitioners.

Materials characteristics, climatic conditions, traffic conditions and construction standards vary throughout the world. This has led to the development of many models, each specific to local conditions and frequently developed or validated using local empirical data. The pavement thicknesses adopted for the CAPTIF test pavement were selected on the basis of providing a pavement that was acceptable to Australasian, European and North American practice. New Zealand empirical design practice at the time suggested that the pavement life was likely to be of the order of 1 to 2 million standard axles (1 - 2 MESALS) for cracking, and approximately 10 MESALS for rutting. At the loading selected for the CAPTIF test, these figures equate to approximately 500 000 loading cycles for cracking and about 2 000 000 loading cycles for rutting.

As an initial step in the accelerated pavement test, several empirical procedures were used to forecast pavement life under the (known) test conditions. Although accurate data could not be provided for all the necessary input parameters, local knowledge of the materials was used to provide reasonably accurate estimates. It was found that not only was the range of lives predicted by the procedures very wide, but also none of the procedures accurately forecast the measured life of the pavement to within an acceptable (+/- 50 per cent) error. Major unknown factors included the effect of the concentrated

wheel path distribution and the lack of adverse environmental influences. This is clearly an issue deserving attention, particularly in view of the important trend towards the use of performance-related specifications for pavement design.

Because most design procedures have been developed and calibrated based on data obtained from in-service pavements, it is quite common for design procedures to inaccurately predict life under accelerated loading. Some of the reasons for this are as follows:

- Although suitable for the primary aim of the study, namely the comparative ranking of performance under two different suspension types, the fact that the test pavement was contained in a concrete tank may have produced edge effects which artificially stiffened the test pavement at its outer boundaries, thus leading to an increased life. Such stiffening could not be monitored during the course of the test as resources did not permit the measurement of stiffness other than at the centrelines of trafficking. As well, such an exercise would have been restricted to a comparison of absolute deflection bowl data rather than back-calculation.
- The CAPTIF facility is located indoors and the occurrence of rain and direct sunlight on a pavement in service contributes to its rate of deterioration. However, the fact that CAPTIF is located indoors was one of the main reasons for its selection because environmental influences would have affected the results from the point of view of isolating the effects of the two suspension types from the effects of any changes in environment, particularly subgrade strength, during testing.
- The distribution of the traffic loading, as is the case with most facilities of this type, is much narrower and much more controlled than would occur with in-service pavements.
- The construction methods used were not typical of normal practice because of the need to construct the pavement within a circular trapezoidal tank and the requirement for uniformity. In addition, the asphalt was hand-laid and compacted using conventional plant.

Even allowing for these factors, the results confirmed that current design procedures, particularly the models used to predict pavement life, are probably conservative. This is especially true in relation to subgrade deformation life models as they are often derived from existing empirical design methods which are, by their very nature, inherently conservative.

An important output of the DIVINE research in this area was the confirmation that the FWD proved to be a very valuable tool in terms of providing the correlation between the deflection data and performance indices, particularly roughness and cracking. The FWD and other similar devices have a very important role to play in the construction process, especially as an aid in ascertaining structural variability. While there was no evidence at CAPTIF that the periodic use of the FWD through the life of the pavement, including its use at construction, would provide any better information regarding long-term performance, this may be different in field situations where factors such as the ingress of water cause local variations in structural strength. Indeed, devices such as the FWD are now being widely used in long-term pavement performance studies and have formed a key part of the US Strategic Highway Research Program (SHRP) Long Term Pavement Performance Program.

### *Pavement performance models*

Mechanistic models are designed to evaluate structural performance whereas pavement performance models are designed to evaluate functional performance. Although a large number of models have been developed for determining pavement response, very few mathematical models have been developed for the prediction of pavement performance -- i.e. roughness, cracking, rutting, etc. There are two major reasons for this: (i) the complexity of the models; and (ii) the lack of relevant performance data that can be used to develop or validate these models.

It was never the intention during the research on the accelerated pavement test to validate performance models or to develop new models. However, on the basis of the CAPTIF test, it would appear to be essential that pavement structural variability and dynamic loading be included in performance models because structural strength and dynamic force were shown to interact. Specifically, a structural weakness of 30 per cent combined with a dynamic impact factor of 15 - 40 per cent caused the only observed failure.

Other factors, such as cracking and rutting, need to be considered in pavement performance models. Cracking damage is slow to accumulate and difficult to measure both in the field and in accelerated tests. Therefore, the characterisation of cracking used in models should reflect the extent of highly cracked areas rather than overall averages of the amount of cracking. Rutting, on the other hand, is a reliable measure of pavement damage and is relatively easy to accurately measure. However, maximum, minimum and standard deviations, as well as the mean values, should be included in monitoring for pavement management systems.

In conclusion, a major pavement-vehicle field testing effort is needed to confirm and expand on the DIVINE findings and validate a vehicle-pavement interactive model. Such a model needs to include the interactive effects of pavement profile, pavement structural variability and dynamic loading throughout pavement life.

#### ***V.1.3 Concepts of pavement life and performance***

As was noted earlier in this report, there are a variety of ways to describe the current structural and functional conditions of a pavement as well as their progress with time and/or traffic. It was stated earlier that both are needed to describe the overall condition of a pavement. This is an important consequence of the DIVINE research, particularly because the results highlight the difficulty of interpretation in only one of these contexts. DIVINE has shown, for example, that from the point of view of vehicle-pavement interaction, functional condition is the most important of the two because of the strong effects of longitudinal profile on the degree of dynamic loading experienced.

It must be remembered, however, that the DIVINE results also underline the interaction between structural condition and functional condition. Variability in the initial structural condition of the pavement leads to the development of changes in longitudinal profile that, in turn, bring about increased dynamic loading. The structural condition of the pavement, including variability in that condition, is most important at construction, and appears to become less important as the effects of changes in longitudinal profile become apparent.

The need to review concepts of pavement performance and consumption of pavement life is emphasised by the DIVINE results. According to the pavement damage results of the accelerated pavement test, air suspensions increased pavement life by 45 - 65 per cent for a particular rutting criterion

and by 30 per cent for a particular cracking criterion. Similarly, the results of the research on pavement primary response indicate that using air suspension in place of steel would increase pavement life by approximately 60 per cent for the thicker pavement studied and by about 15 per cent for the thinner pavement. Taken together, these results suggest that there is a need to consider whether current pavement design methods should be modified to take into account both the consequences of dynamic loading -- including a provision for the different effects on thicker or thinner pavements -- and the important question of structural variability.

The results of the spatial repeatability tests indicate that, on a road of smooth to medium roughness, pavement life would be reduced by 30 - 50 per cent as a result of the concentration of wheel loads at certain locations. Clearly this result has some significance for the pavement design method used, but it is perhaps more relevant to the matter of the longitudinal profile of the road, and its maintenance at, or better than, a given characteristic value. The results of DIVINE therefore suggest that it will be necessary to review the concept of pavement life, both from the point of view of structural condition and functional condition.

## **V.2 Bridges**

The main parameters governing the problem of dynamic bridge response to the passage of heavy commercial vehicles are:

- the bridge natural frequencies;
- the longitudinal profiles of the bridge approaches and the bridge itself;
- the frequencies of the vehicle's dynamic wheel loads; and
- the magnitude of the dynamic wheel loads.

Bridge response to heavy vehicles is usually expressed as a static component plus an allowance for dynamic effects. The dynamic load allowance (DLA) is a portion of the static component and has traditionally been a function of the average span of the bridge. Some modern codes express the DLA as a function of the fundamental frequency of the bridge, others specify one value for all bridges and still others include provisions to take account of the longitudinal profile. The DIVINE Project has demonstrated that there is a need to include DLA in all cases.

The quality of heavy vehicle suspensions is not considered by bridge design codes as there are no established procedures for including the effects of vehicle suspension in design. Road profile is similarly neglected despite being universally recognised as very significant in relation to the dynamic response of bridges. The DIVINE research has shown that the dynamic response of bridges can only be understood when considered as part of a system which incorporates the bridge, the road profile and the vehicle mass, configuration and speed as well as the vehicle suspension. The need to understand this complex system is becoming increasingly important in an era when ageing and deteriorating bridge infrastructure must carry ever increasing loads in response to industry and government efforts to improve transport efficiency.

The DIVINE Project has gathered some unique data which suggest ways of providing improved guidance for those involved in each aspect of the bridge industry -- design, maintenance, evaluation and

management. Likewise, the DIVINE research suggests the need to develop more “bridge-friendly” suspension systems.

### ***V.2.1 Bridge response to dynamic wheel loads***

#### *Long-span elements of bridges ( $L > 100$ m)*

The type of vehicle suspension is of little significance on bridges in this category unless the road profile is poor. This is because the effect of live load is relatively small in comparison to the critical events corresponding to the summed effects of groups of vehicles that each vibrate with their own characteristics. It is also less critical than the dead load imposed by stationary vehicles. Furthermore, the fundamental frequency is less than those evident in heavy vehicles and thus these bridges tend to attenuate the dynamic components of the wheel forces.

#### *Medium-span bridges ( $L \approx 30 - 100$ m)*

Frequency-matching with the truck body bounce frequencies occurs in medium-span bridges. Softer air suspensions will result in increased dynamic responses compared with steel-suspended vehicles on bridges with natural frequencies in the range 1.5 to 1.8 Hz (maximum span  $L \approx 70 - 60$  m). The reverse is true for bridges with natural frequencies in the 2 to 4 Hz range ( $L \approx 60 - 30$  m). The testing showed that the dynamic responses were well within code recommendations for high-quality road profiles. Further research is required to quantify the effects of rougher profiles.

#### *Short to medium-span bridges ( $L \approx 15 - 30$ m)*

Bridges with natural frequencies in the range of 4 to 8 Hz tend not to dynamically couple with vehicles at either body bounce or axle-hop frequencies. Generally, air-suspended vehicles will induce less response than the equivalent steel-suspended vehicle and the response is likely to be less than the code recommendations as long as the road profile is acceptable.

#### *Short-span bridges ( $L \approx 8 - 15$ m)*

The DIVINE research has demonstrated that “quasi-resonance” occurs between short-span bridges and the axle-hop vibrations of heavy vehicles, but with minimal amplification. The effects of body bounce are also transmitted to short-span bridges with minimal amplification. The dynamic response of short span bridges can be much larger than expected for dynamic effects. This is true for both steel and air suspensions provided the road profile exhibits short wavelength roughness sufficient to excite axle-hop vibration.

The largest dynamic increment recorded was 137 per cent. It was associated with the passage of an air-suspended vehicle crossing a short-span bridge at a speed of approximately 60 km/h and highlighted the importance of road profile and the need for effective dampers. This, and other slightly smaller events, demonstrated that the passage of a single legal vehicle (with “road-friendly suspensions” or conventional suspensions) over a short-span bridge exhibiting short wavelength roughness can induce

effects whose magnitude is equivalent to a grossly overloaded vehicle or two design vehicles plus the code recommended DLA.

The short-span bridge response to air-suspended vehicles exhibited a large number of damaging stress cycles with amplitudes in excess of the maximum deflection/strain. The amount of fatigue damage can be one to two orders of magnitude greater than the assumption of one stress cycle per vehicle. These effects were limited to a relatively narrow speed range (around 60 km/h) where the axles in the group vibrated in phase. The effects are true of air suspensions with good damping and are exacerbated for vehicles with ineffective dampers. Increased damping in the bridge also reduces this effect.

### V.2.2 *Summary*

The implications of the DIVINE research into bridges are as follows:

1. Vehicle suspensions are important in determining the dynamic response of bridges under a single vehicle.
2. Air suspensions may induce smaller dynamic responses in bridges.
3. For short-span bridges without smooth profiles, soft or so-called “road-friendly suspensions” may not be “bridge-friendly” if the bridge has a natural frequency corresponding to the body bounce frequency or if it has a short-span (natural frequency corresponding to axle-hop) and exhibits short wavelength roughness.
4. Road profile is very important in determining the dynamic response of bridges. To effectively maintain a bridge also includes maintaining the profile within acceptable criteria. These criteria require development.
5. The dynamic load allowances specified in bridge design codes should be a function of both the fundamental natural frequency (extended to include axle-hop frequencies) and the road profile. The DLA is different at the serviceability, fatigue and strength limit states.
6. The effective damping of soft suspensions is essential. Further understanding of the effectiveness of dampers fitted to both new and used air-suspensions is required.

The maintenance of smooth approaches and profiles across bridges is a very important factor in reducing damage to bridges. Long wavelength roughness is important for all bridges in that it induces body bounce forces which are transmitted with limited amplification in short-span bridges and amplified by medium- and long-span bridges.

Axle-hop inducing short wavelength roughness is less important for the main longitudinal elements of medium- to long-span bridges because no frequency-matching and, consequently, no quasi-resonance effects occur. However, the presence of short wavelength roughness such as pot holes and mis-aligned joints will result in axle-hop vibrations that are amplified by short-span bridges and short-span sub-elements of longer-span bridges. Bridges with a smooth road profile are largely insensitive to vehicle suspension.

Intuitively, it is clear that a poor profile is detrimental to the performance of a bridge. However, bridge design codes provide little or no quantitative advice related to the significance of the road profile to

those designing or evaluating the strength of bridges or maintaining bridges. The DIVINE research has shown that road profile, bridge natural frequency and bridge damping are important elements that need to be controlled by those responsible for bridges.

Road profile measurement is now routine and signal processing technologies are being invoked to improve the quantitative summaries of the data. The measurement of dynamic wheel forces and bridge responses can now also be undertaken relatively straightforwardly. The DIVINE Project also demonstrated that dynamic vehicle models can accurately reproduce dynamic wheel forces and many researchers have demonstrated that the bridge/vehicle interaction problem can be solved analytically. The tools are therefore in place to address the need to develop and validate bridge code models that include road profile and bridge natural frequency in their recommendations for dynamic load allowances. It is recommended that guidelines be developed to facilitate the identification and ranking of longitudinal profiles of bridges and road approaches in terms of their damaging effects to both bridges and heavy vehicles.

As the trend towards heavier vehicles operating on an ageing bridge infrastructure continues, the need for a closer understanding of the vehicle/road profile/bridge system is of crucial importance. Although the DIVINE Project investigation has been restricted to a limited number of vehicles and bridges, the research has shown that the dynamic response of bridges is sensitive to subtle changes in the road profile, the type of bridge and the vehicle suspension. For example, the number of axles in a group, the effectiveness of dampers in air suspensions and the position of short wavelengths in the road profile are likely to be important for short-span bridges. It is also known that the number of vehicles on a bridge tends to decrease the dynamic effects in bridges.

There are many variables involved in determining the level of performance of dampers. These involve both the geometric arrangements of the damper as part of the suspension system, and its damping performance. The technology to cost-effectively determine if a damper is properly operating while it remains fitted to a heavy commercial vehicle is not yet available to the transport industry. It is therefore entirely possible that vehicles can operate with ineffective dampers and thus increase their effects on short-span bridges. The effects of dampers on dynamic loading in the axle-hop modes and their related consequences for short-span bridges require further investigation. It is therefore recommended that the effectiveness of the suspension damping of heavy vehicles in service is investigated with a view to: (i) understanding the likely damaging effects on bridges; and/or (ii) determining the level of suspension performance validation that is necessary.

### **V.3 Vehicles**

As well as building on a decade of research into various aspects of the general topic, the DIVINE Project originated as a result of technological improvements in vehicle suspensions and the desire to investigate the benefits of these changes on pavement life. The trend towards the use of air suspensions on heavy vehicles has been under way for several years. But even as many new vehicles are being fitted with air suspensions in a number of OECD Member countries, the majority of trucks using the roads are fitted with steel suspensions. In addition, at this stage, the use of air suspension on new trucks remains far from universal or standard as some countries are tending to have air suspensions on new trailers and some are tending to have air suspensions on new trucks and tractors.

There are many reasons for the use of air suspensions on newer vehicles. In addition to better ride quality for both drivers and freight, air suspensions have the potential to improve almost every aspect of heavy vehicle dynamic performance, including the safety-related aspects of stability, braking and

tracking. They also distribute loads more evenly between axles and reduce the heavy vehicle environmental impacts related to noise and vibration.

Relative to conventional steel suspensions, current air suspensions are known to reduce most aspects of dynamic wheel loading by virtue of a low bounce frequency, very little friction and a large degree of viscous damping provided by hydraulic shock absorbers which are an integral part of the suspension. There have been some concerns about the performance of air suspensions when the dampers lose part of their effectiveness in service. Although it has been suggested, for example, that air suspensions with worn shock absorbers may have no advantage over steel spring suspensions and may actually create higher dynamic loading under some circumstances, there is little current evidence to support this claim.

It is also known that some modern steel spring suspensions, such as taper-leaf types, have dynamic properties similar to air suspensions and therefore also have the potential to reduce dynamic road loading. For this reason, the EC introduced a simple bounce test which could be used to prove the equivalence of steel spring suspension to air suspension. Thus, while current air suspensions and some steel suspensions are known to have desirable characteristics, some efforts are under way to further improve suspension technology and it may be that further gains in road-friendliness can be achieved.

The DIVINE Project concentrated on suspension effects because the suspension is the single element of the vehicle-infrastructure system which can be readily changed to make a positive improvement in system performance. It is recognised that vehicle configurations and wheel-bases can also influence dynamic wheel loads and it has also been shown that tyre contact affects the manner of transmission of dynamic wheel forces through the various pavement layers. However, the main focus of DIVINE was to effectively quantify the benefits to highway infrastructure of road-friendly suspensions.

### ***V.3.1 Current air and steel suspensions***

A range of current suspensions -- including air, steel and rubber springs -- were involved in the experiments carried out in Elements 2, 3, 5 and 6 of the DIVINE Project. From Table V.1, it is apparent that there was a high degree of convergence for the damping of the steel suspensions and for the frequency of air suspensions. However, the damping in the test air suspensions varied dramatically whereas steel suspensions exhibited variations in frequency.

**Table V.1. Frequency and damping of the test suspensions**

<b>Suspension</b>	<b>Frequency</b>	<b>Damping</b>
Older North American air suspension:	1.51 Hz	7 per cent
Newer North American air suspension:	1.45 Hz	20 per cent
Newer European air suspension:	1.4 Hz	35 per cent
Older North American steel suspension:	3.16 Hz	10 per cent
Newer North American steel suspension:	2.75 Hz	6 per cent
Older Australian steel suspension:	3.2 Hz	10 per cent
Newer European steel suspension:	2.08 Hz	11 per cent

It is clear that the current EC requirement of 2 Hz maximum frequency and 20 per cent minimum damping generally succeeds in differentiating between air and steel suspensions but is less appropriate to its original purpose of specifying performance equivalent to air suspension.

### ***V.3.2 Suspension performance requirements***

The results of Element 3 of the DIVINE Project showed that the dynamic loading generated by suspensions is sensitive to both the frequency and damping of the suspension, as measured in the EC bounce test. It was also found that the frequency and damping of air and steel suspensions are not independent parameters. For practical reasons, it is difficult to design a steel suspension with good damping and a frequency below 2 Hz.

The sensitivity of dynamic loading to suspension damping is such that there is very little increase in dynamic loading as the damping reduces from 20 to 15 per cent, a slightly greater increase as damping is further reduced to 10 per cent and then a strong increase as damping is reduced below 10 per cent. This is particularly true if the suspension frequency is limited to 1.5 Hz.

It was also found that there is limited value for reducing dynamic pavement loading in reducing suspension frequency below 1.5 Hz or in increasing damping beyond 20 per cent. However, damping greater than 20 per cent could have benefits for heavy vehicle safety performance and for reducing axle-hop vibrations under severe conditions of road roughness.

It is recommended that a “road-friendly” suspension should be defined by the following criteria, as determined in the EC bounce test:

- frequency of 1.5 Hz or less;
- damping of 20 per cent or more.

### ***V.3.3 Assessing vehicles for road-friendliness***

The EC bounce test was found to be a useful test for characterising suspension frequency and damping. It is recommended that the analysis of the test data is modified to specify that only the second and third peaks are taken into account for determination of the damping coefficient.

It would also be desirable to have a simple suspension test that could be applied in service, either in government test stations or in vehicle maintenance workshops. Element 3 of the project developed a 1 mm Simultaneous Sinusoidal Sweep (SSS) test which proved effective in differentiating between the dynamic characteristics of the suspensions tested. It is recommended that this test be further developed for in-service use.

### ***V.3.4 Road simulators***

Road simulators can be used to generate dynamic loading closely representative of on-road behaviour provided that all axles of the vehicle are excited by the simulator.

### **V.3.5 Computer simulation models**

Simulation models which model the vehicle in three dimensions and utilise non-linear hysteretic representations of steel springs have the potential to predict dynamic wheel loads with acceptable accuracy.

### **V.3.6 Performance under extreme conditions of road roughness**

It was found in Element 6 of the DIVINE Project that, under extreme conditions of abrupt changes in road profile on some bridge approaches, it was possible to generate high dynamic loading related to high-frequency axle-hop vibrations. Levels of suspension damping higher than that recommended in Section V.3.2 would be required to control such vibrations and further investigation of the need for, and feasibility of, controlling such axle-hop vibrations using suspension performance standards is recommended.

### **V.3.7 Implementation of suspension performance standards**

In order to reduce pavement wear and to provide the potential for increased axle weight limits, it is recommended that road-friendly suspension performance standards, based on the criteria recommended in Section V.3.2, are introduced. Such standards could be introduced on a type-approval basis and requirements should be adopted uniformly among OECD Member countries.

The question of how much additional static weight could be carried on a road-friendly suspension for the same pavement wear remains difficult to answer. Element 1 of the DIVINE Project has provided some experimental evidence that air suspensions will provide longer pavement life than steel suspensions for the same static load. Pavement primary response results from Element 2 of the DIVINE Project, assuming a fourth power law, suggested that air suspensions increase pavement life by 15 to 60 per cent, depending on the pavement thickness. This would equate to a static load increase of 4 to 12 per cent, again using a fourth power law. Such increases in axle weight would provide a highly significant improvement in road freight productivity and a significant reduction of indirect user costs.

It is recommended that further experimental work is now undertaken to compare pavement performance under steel and air suspensions, with the air suspension carrying a higher static load. This would provide a firmer basis for setting differential weight limits for steel and air suspensions.

## **V.4 Research needs**

### **V.4.1 To what extent did the DIVINE project meet its objectives?**

#### *The influence of heavy vehicle suspensions on road life and costs*

The results showed that suspensions and dynamic loading directly affect pavement responses and that changes in pavement unevenness, and other forms of distress, progress more rapidly under steel suspension than under air suspension. The power of these findings is limited by the circumstances of the single accelerated pavement test carried out and difficulties in extrapolating the results to actual highways.

More work is definitely needed in this area and the DIVINE results provide a strong basis for the design of future experiments.

No information was obtained to directly relate changes in pavement life to pavement costs.

#### *The influence of heavy vehicle suspensions on bridge life and costs*

For medium- to long-span bridges, the influence of the live traffic loads on bridge design and maintenance costs is limited because the ratio to the dead load is generally rather small. On the other hand, live loads are likely to be important for short-span bridges. Provision for dynamic loads has already been introduced in current codes and in the newly-drafted Eurocode 1, Part 3 (Traffic Loads on Road Bridges). The dynamic traffic loads may also lead to life reduction by an increase of the fatigue damage in steel bridges or steel parts of composite bridges. Extensive research work was carried out on this subject by the European Community for Steel and Coal from 1978 to 1992. The output of this work was taken into account in the Eurocode 3 (Steel Construction). Additional research work would be useful to better account for the effect of vehicle characteristics such as the suspension type on these dynamic loads.

#### *Consequences for bridge design of road-friendly vehicle suspensions*

The DIVINE results show that some additional design code considerations should be introduced for medium-span bridges. Additional design considerations for suspensions should be developed for short-span bridges with rough approach and bridge deck conditions. Further work is therefore needed to assess the need for, and feasibility of, such suspension design changes.

#### *Specification and testing of road-friendly vehicles*

The DIVINE results provide a performance specification for road-friendly suspensions which builds on the EC specification for equivalence to air suspension and provides rational criteria based on limiting dynamic road loading

#### *Maintaining road-friendly vehicle performance in-service*

It was found that damper effectiveness is important to road-friendliness. Element 3 developed a new suspension test which could be applied in-service and which has distinct advantages over the drop test and full-scale shaker tests. This test is able to provide a more accurate assessment for suspension damping and to extend the parametric specification to the high-frequency as well as the low-frequency behaviour of the suspension. It could be further developed to be applied in government test stations and vehicle maintenance facilities. More work is needed to make this new test fully operational. It is also important to ensure that suspension damping meets appropriate safety criteria because safety considerations may place greater demands on damper performance than road-friendliness and may require further research.

#### *Road condition indices relevant to truck effects*

PSD-based profile indices provide more information than IRI on vertical surface deformations related to dynamic loading.

The DIVINE Project has demonstrated the importance of spatial repeatability of dynamic road loading. Further work is needed to determine whether a profile index could be developed which would provide information on the spatial repeatability potential of road profiles.

#### *Encouragement of the design and use of road-friendly vehicles*

Through its six Research Elements, the DIVINE Project has produced a much clearer view of the physical effects of road-friendly suspensions relative to conventional suspensions. This information can be used at many levels to encourage the use of road-friendly vehicles.

#### *Policy options for axle loads and axle configurations*

The DIVINE results apply mainly to the influence of suspensions and the effects of dynamic loading. Extensive work is needed to fully understand the effects of axle loads and closely spaced axle groups on pavement wear and pavement life. DIVINE provided improved understanding of the vehicle-infrastructure interaction that will provide guidance in designing suitable experiments and investigations.

It would also be desirable to develop WIM networks to perform large-scale recording of the real axle impact forces applied on pavements as well as to control loads with respect to legislation. This is necessary for infrastructure -- bridge and road -- protection, but also to ensure fair competition between the various transport modes.

#### *Road cost allocation*

The DIVINE results provide no direct information on road cost allocation but indicate that current pavement design and strategic evaluation procedures may over-estimate the effect of wheel loads in relation to pavement condition effects. Given the important place of cost recovery in road funding, and the significant allocation of road costs to truck weight and truck travel, extensive research is needed to better understand the relative contributions of truck weight, vehicle road-friendliness, road initial and current condition and environmental effects to road wear and road damage. Again, the DIVINE results will greatly assist in designing an effective research programme.

### ***V.4.2 What research is needed to further improve the relationship between heavy vehicles and the infrastructure?***

#### *Vehicles and pavements*

The largest question touched on by the DIVINE results is the overall role of heavy vehicles and their wheel loads -- static or dynamic -- in creating pavement wear and pavement damage. The DIVINE results show that it is difficult, and probably inappropriate, to partition the influences of the vehicle, the pavement and the environment. These elements need to be researched in an interactive way. The DIVINE results indicate that current pavement design and evaluation techniques may tend to over-estimate the direct contribution of heavy vehicle loads to the shortening of pavement life in relation to the influence of pavement profile, pavement structural variability and the environment. Further research questions have been raised and the DIVINE results should be used to design an appropriate research

programme to address these questions. The results of this research are highly relevant to the issue of cost allocation.

Subsidiary to this overall issue is policy-related information concerning heavy vehicle regulations and possible incremental changes in such regulations as described in the following:

- How much more road maintenance and other costs are associated with a certain increase in axle weights?
- How much more weight can be allowed when a further axle is added to a vehicle (for example, substituting a tridem for a tandem axle group)?
- How much more weight can be allowed when a road-friendly suspension is substituted for a non-road-friendly suspension?

The results of DIVINE show that such issues need to embrace a full range of pavement construction, pavement condition and vehicle configuration variables in order to arrive at realistic and credible answers. Although the DIVINE Project has made a promising start in these areas, further research is needed and should be based on analysis of pavement functional condition.

To support the implementation of improved regulatory policies, it is necessary to have access to credible and practical tools for assessing pavements and vehicles. Although further research is required, DIVINE made a strong contribution in the following areas:

- *Measurement of pavement structural condition and its variability:* DIVINE found that the FWD or similar devices are powerful tools for this purpose.
- *Measurement of pavement functional condition:* Although profilometer technologies are well developed, DIVINE found that current profile indices require further development to better reflect dynamic loading and spatial repeatability.
- *Means of assessing the road-friendliness of suspensions:* DIVINE provided several methods for doing this.
- *Means of assessing tyre effects:* More research is needed into the way dynamic loads are transmitted through the tyre into the pavement structure, especially for thinner pavements.
- *Validated modelling of pavement functional condition in response to the dynamic interaction of vehicles and pavements:* DIVINE provided guidance on effective vehicle models and further work is now needed to develop, evaluate and validate vehicle-pavement dynamic models of functional condition.
- *Measurement, on a large scale, of dynamic axle and vehicle loads and impact forces by developing WIM networks:* MS-WIM systems should be used for further investigation of the patterns of the dynamic loads.

In addition to the above research involving the interaction of vehicles and the pavement, the DIVINE Project has highlighted the need to enhance technologies for the design and function of pavements. Specific areas in which the DIVINE results have highlighted the need for further research are:

- improved methodologies for pavement mechanistic design;
- review of damage criteria used in mechanistic pavement design;
- increased emphasis on pavement functional condition, along with structural condition in mechanistic design;
- greater consideration of structural variability, dynamic loading and spatial repeatability in mechanistic pavement design;
- benchmarking of accelerated pavement tests against field tests, especially with regard to functional performance; and
- development of improved pavement response instrumentation with better reliability and accuracy in addition to lower cost so that higher quality data may be obtained for developing and validating pavement models.

### *Vehicles and bridges*

The largest question raised by the DIVINE bridge results focuses on the relationship between bridge primary response, in terms of deflections and stresses, and bridge fatigue life and costs. The DIVINE Project has shown that, under certain conditions, dynamic loading from heavy vehicles can generate multiple cycles of amplified bridge responses. Research is needed to determine the effect of such responses on bridge deterioration and costs.

The DIVINE bridge results have shown that bridges, with the exception of those with very long spans, need to be designed for dynamic loading across the full spectrum of vehicle dynamic loading. Current bridge design codes consider only low-frequency vehicle loading and take little account of the evenness of bridges and their approaches. Further research is needed to support the inclusion of these effects in the Dynamic Load Allowances in bridge design codes.

It is also necessary to have the means for identifying existing bridges which are likely to be susceptible to dynamic loading from heavy vehicles. The DIVINE Project has shown that the natural frequency of the bridge and the profile of the bridge and its approaches are important factors in the generation of dynamic loading and in the amplification of the bridge's response to that loading. Research is needed to develop guidelines for the identification of bridges which are exposed to dynamic loading effects and for maintenance activities to improve the approach profile.

The DIVINE results have also shown that vehicle suspensions, particularly those with poor damping, can interact with bridges. Further research is needed to determine whether suspension design changes, or additions to currently proposed "road-friendliness" requirements, are needed to take account of these unique vehicle-bridge interactions.

### ***V.4.3 How can improved knowledge of the physical interactions lead to practical models of costs to road providers as well as road users?***

More effort is needed to develop comprehensive models of costs of road transport to agencies and to users. The greatest difficulties in developing and using such models lie in the ability to predict:

- the effects of maintenance activities on functional condition and structural condition of pavements;
- the effects of high-intensity dynamic loading of bridges on bridge life and agency costs; and
- the effects of pavement functional condition on vehicle operating costs, including the influences of speed and travel time, tyre wear, fuel consumption, vehicle ride quality and vehicle durability.

With regard to future research efforts in these areas, the DIVINE results have demonstrated the need to place more emphasis on the influence of maintenance activities on structural variability and on improving the functional condition of road pavements.

## **V.5 Summary findings**

In summary, the DIVINE project led to the following significant scientific findings:

1. Primary responses of pavements reflect the total dynamic loading applied by heavy vehicles for dynamic wheel loading frequencies up to at least 15 Hz.
2. Primary responses are directly proportional to total load, including dynamics, for thick pavements (approximately 150 mm thick) and are proportional, with a lower sensitivity, for thin pavements (approximately 80 mm thick).
3. An accelerated dynamic test has shown that pavement profile deteriorates more rapidly under a steel suspension than under an air suspension carrying the same load. Some aspects of cracking and the maximum rut depth were also greater under the steel suspension. Pavement wear under the steel suspension was at least 15 per cent faster than under the air suspension.
4. Road simulators (shakers) replicate dynamic wheel loads measured on the road provided that all axles of the vehicle are excited. The accuracy of replication of dynamic loads is typically 3 per cent or better as measured with the Dynamic Load Coefficient.
5. The essential properties of road-friendly suspensions have been confirmed as low spring stiffness, very low Coulomb friction and an appropriate level of viscous damping. Such properties are to be found in well-designed and well-maintained air suspensions and it is unlikely that steel spring suspensions could achieve the desired level of performance. A method of measuring these parameters is suggested that may be more accurate and consistent than the drop and step tests currently used.
6. The use of air suspensions on the drive and trailing axles of heavy vehicles (perhaps with the exception of the steering axle) would reduce road wear and should be encouraged.
7. Some computer simulations of dynamic wheel loads are capable of calculating these loads to an accuracy of approximately 5 per cent, as measured with the Dynamic Load Coefficient. It is essential for these models to accurately represent the non-linear characteristics of the suspension, particularly the Coulomb friction in steel leaf springs.

8. Under mixed traffic, dynamic loads typically tend to concentrate at points along a road at intervals of 8 - 10 metres. On a smooth road, the cumulative sum of axle loads at a point of concentration is about 10 per cent. On a rough road, this effect is at least twice as large. The concentration of dynamic loads for air suspension has only about half the magnitude of that for steel suspensions.
9. The surface profile of a bridge and its approaches are fundamental to the response of the truck suspension and in turn the dynamic response of the bridge. For a smooth profile, the influence of the truck suspension is insignificant but its importance increases as the unevenness of the profile increases.
10. For medium- to long-span bridges (20 - 70 metres) with smooth profiles, dynamic responses are relatively small for both air-suspended and steel-suspended vehicles. Within this range, increased responses occur for air-suspended vehicles on 1.6 Hz (70 metre) bridges and for steel-suspended vehicles on 3.0 Hz (40 metre) bridges. For short-span bridges (10 metres) with poor profiles, large dynamic responses occur for both air-suspended and steel-suspended vehicles. The highest measured responses were for short-span bridges with poor damping that are traversed by air-suspended vehicles with specifically-excited axle-hop vibrations.

**ANNEX A**  
**TERMINOLOGY AND BRIEF OVERVIEW OF PAVEMENT DESIGN, PAVEMENT**  
**CONDITION ANALYSIS AND BRIDGE DESIGN**

**A.1 Terminology**

**A.1.1 Pavement primary response**

The current state of stress, strain or displacement occurring at some point in the pavement due to the passage of a loading unit on the surface of the pavement.

**A.1.2 Damage**

Pavements do not experience catastrophic failure. They normally fail due to the incremental accumulation of small but finite quantities of *damage* that exist after one or more repetitions of the loading unit. The damage may occur in terms of finite amounts of shear or volumetric permanent deformations or in terms of finite tensile strains sufficient to cause an incremental amount of fatigue damage. In either case, these small but finite amounts of damage accumulate to become visible and non-visible defects -- permanent deformations or cracks -- throughout the pavement.

**A.1.3 Distress**

The defects which occur at the weakest points in the pavement and at points where the loading is highest are further influenced by environmental effects and through interactions with other defects. They are finally manifest in visible (or measurable) surface defects called pavement *distress*.

**A.1.4 Pavement wear**

An expression of the rate of progression of the various modes of the measurable distresses. For roads subject to *fatigue cracking*, pavement wear is exponentially related to wheel load, perhaps according to a fourth power relationship. In the case of roads subject to *permanent deformation*, the pavement wear relationship also has a "power" relationship, perhaps as low as unity (OECD, 1992). The term pavement wear is sometimes applied to the deterioration of pavement surface properties such as skid resistance, but in this report it will be used as defined above.

## **A.2 Development of pavement structural design procedures**

### ***A.2.1 Empirical design***

The origins of empirical pavement design charts can be traced to the California State Highway Department which developed the California Bearing Ratio (CBR) method of pavement design (Porter, 1942). Between 1928 and 1942, the Department examined the quality and thicknesses of base, sub-base and subgrade materials under both failed and sound sections of flexible pavements throughout the California highway system. From these data, curves were formulated for determining the total depth of construction (base, sub-base and imported fill) required to carry the anticipated traffic.

In the late 1940s the United Kingdom's Road Research Laboratory (RRL) compared the total pavement thicknesses required by the Californian CBR method with actual thicknesses of roads of various condition. Later, a series of full-scale experiments of in-service roads was conducted to examine the performance of roads with variations in materials and layer thicknesses. Sufficient data were available by 1960 to issue preliminary design standards (Road Research Laboratory, 1962). In 1965, the second edition was extended to lightly-trafficked roads.

It should be noted that empirical models have their limitations. They have been developed from regression analyses of experimental or observed data. For this reason, although these models are useful when the mechanism of pavement performance is not understood, they should not be used beyond the range of data from which the model was developed.

### ***A.2.2 AASHO Road Test***

The start of modern road pavement testing using controlled, accelerated loading, as opposed to "in-service" experimental sections built into a highway network, can be taken as the American Association of State Highway Officials (AASHO) Road Test (Highway Research Board, 1962), which was conducted in Illinois between August 1956, when construction of the test facilities commenced, and November 1960, when trafficking was terminated. The principal objective of the research was to establish relationships between performance, structural design (i.e. component thicknesses of the pavement structure) and loading (i.e. the magnitude and rate of application of axle loads). As one of the basic aims of the study was to evaluate the performance of pavements through failure, many were designed to fail under load or at least show severe distress.

The findings were presented in the form of equations and graphical representations showing the specific effects of particular variables on pavement performance. This presentation allowed the change in performance to be associated with specific changes in axle load and the number of load repetitions.

The original axle load equivalency concept developed from the AASHO Road Test was used to convert the number of passes of a particular axle load and configuration which caused a certain level of terminal pavement damage into the number of Equivalent Standard Axle Loads (ESALs) which would cause the same damage. The concept was expressed in the form of a "power law" and because a power of four was obtained from an analysis of the AASHO Road Test data, the law became known as the "fourth power law".

This law was later widely adopted into practice, especially in empirical design procedures, because it allowed the "design traffic" to be expressed in terms of ESALs over the design period rather than "number of commercial vehicles". In other words, use of the law allowed design to be based on mixed traffic of various axle loads and configurations.

For the same reasons that empirical design procedures should not be used beyond the range of data from which the model was developed, the use of the "fourth power law" may not be appropriate in all situations unless the environment, traffic, pavement type and pavement construction methods are the same as, or very similar to, those in the AASHO Road Test.

The remaining problem with the application of vehicle damage factors (ESALs) is that, although they may be useful in assessing various pavement design options, they give no indication in themselves of long-term pavement performance, which is dependent on a range of other factors. With the benefit of widespread and lengthy experience in their use, it may also be suggested that some of the assumptions behind the derivation of the exponents in the expressions for these factors can also be criticised, such as the premise that loads causing equal deflection also cause equal damage.

In addition to its pioneering work in the field of pavement performance, the AASHO Road Test also encompassed pioneering work in the experimental investigation of dynamic vehicle/bridge interaction and of simulating the related processes with computer models.

### **A.2.3 Mechanistic design**

Pavement design has evolved from the empirical approach to a more fundamental approach where the pavement is treated as a civil engineering structure which, with knowledge of the properties of the constituent materials, is amenable to an analysis of, firstly, its response to an applied load -- i.e. the stresses, strains and displacements developed in the structure in response to the applied load -- and, secondly, its performance when subjected to many repetitions of the applied load -- i.e. the progressive deforming of all materials and the initiation and progression of cracks in bound (bituminous or cemented) materials.

The most common response models used are linear elastic models, although response can also be determined using various types of finite element models and viscoelastic models. The response to load data are then input into some type of performance model and the "life", or number of repetitions of that load used in the response modelling, determined. The procedure is iterative in that the thickness and/or stiffness of the constituent materials is adjusted until the predicted life is greater than the "design", or anticipated, life.

Various performance models have been adopted. For example, the most commonly used model for the fatigue life of bituminous materials is that used in the Shell design method (Shell, 1978), which was based on the results of laboratory testing. Many performance models for cemented materials are also based on laboratory testing but, more recently, these have been refined following controlled accelerated pavement testing (Jameson *et al.*, 1992). The damage exponents in these models vary widely, with values as high as 18 being reported in the literature. Similarly, a variety of models have been suggested for the performance of granular and subgrade materials. Those based on empirical design charts for granular materials generally include an inherent design conservatism that has implications for the appropriate subgrade strain criterion for use in pavement design and overlay design.

Although the use of primary response measures such as changes in stress, strain and deflection due to imposed loads on the pavement is useful for designing pavements with new materials, it does not lead on its own to a pavement performance prediction model. This is because the performance of a pavement with time depends on variables that are often not directly related to primary response measures. The progression of a functional performance measure, such as pavement evenness, is largely due to pavement and subgrade strength variations, layer thickness variations throughout the pavement structure, and the non-uniform change of these properties with time under the dynamic nature of pavement loading and the environment.

One of the first operable mechanistic design procedures produced to predict long-term pavement performance was the Viscoelastic Structural Subsystem (VESYS) (Kenis, 1978). The extensive amount of detailed input data required for meaningful performance estimates was sufficient, however, to limit its use to researchers and to the university classroom. Several advanced versions have since been developed and the latest version, VESYS 5, should be ready for dissemination in 1998. Although the program inputs are as complex (if not more so) as earlier versions, and allow for viscoelastic materials, multiple axles and dual or single wheels, it is hoped that with the current and improved level of knowledge of mechanistic design and with the availability of increased computer computation speed and accuracy, practical field usage will ensue.

The Mathematical Model of Pavement Performance (MOPP) (Ullidtz, 1987) was developed between 1976 and 1985, and is of particular interest because of its ability to predict longitudinal roughness. Like VESYS, the model is complex, but good agreement was obtained between its predictions and the actual results obtained from part of the AASHO Road Test, and with results obtained from tests in an accelerated pavement test facility. Cambridge University (Collop and Cebon, 1995) has recently developed a new "Whole-Life" Pavement Performance Model (WLPPM) using primary response measures, including dynamic load effects, to predict long-term pavement performance. The model is at an early stage of development and uses a number of simplifying assumptions regarding the nature of the pavement variables. Parametric studies so far indicate reasonable correlation of the model with observed long-term pavement behaviour.

#### ***A.2.4 Accelerated pavement testing***

Although many existing pavement thickness design and material selection procedures are based on the findings of many full-scale pavement tests conducted in many countries, this approach has its limitations in terms of its relevance to the increased vehicle numbers and loads and the new axle and wheel configurations now encountered. For this reason, there has been a trend in recent years for road agencies to conduct major research programmes in which "in-service" long-term pavement performance (LTPP) monitoring is combined with full-scale accelerated pavement testing (APT), and laboratory materials characterisation in an attempt to better understand road pavement performance.

In addition, the need to optimise available resources has led to the development of new, innovative, marginal or non-standard materials and by-products. APT is well suited to these types of studies because data regarding the performance of materials can be quickly collected and easily compared to the performance of those materials already commonly, and successfully, used in practice. In other words, APT can be used to "rank" materials and/or processes.

APT can be defined (Metcalf, 1996) as the controlled application of a prototype wheel loading at or above the appropriate legal load limit to a prototype or actual layered, structural pavement system to determine pavement response and performance under a controlled, accelerated accumulation of damage in

a compressed time period. The acceleration of damage is achieved by means of increased repetitions, modified loading conditions, imposed climatic conditions (e.g., temperature and/or moisture), the use of thinner pavements with a decreased structural capacity and thus shorter design lives or a combination of these factors. Full-scale construction by conventional plant and processes is desirable in order that the results can be more confidently incorporated into practice.

The United States National Co-operative Highway Research Program (NCHRP) recently commissioned a review of full-scale APT throughout the world (Barbour, 1993). The survey found that, although mechanistic design procedures are being developed in many countries, they have often not replaced existing empirical and semi-empirical methods or design "catalogues". The validation of theoretical response models and performance prediction procedures is thus an important feature of APT programmes. For example, Scazziga *et al.* (1987) applied APT to the evaluation of pavement stress/strain measurement technologies for bituminous pavements at the OECD co-ordinated test track experiment (Nardo, Italy) conducted in 1984 (OECD, 1985). It was found that the strain measurements were susceptible to large variations due to the heterogeneity in properties of the materials and layers, variation in pavement temperature and to the transverse location of the loads with respect to the location of the strain gauges within the pavement. Other difficulties in correlating measured and predicted strains and deformations can also be related to variation in construction quality and the fact that the assumptions inherent in many of the pavement response models (e.g. linear elastic behaviour) do not relate to actual behaviour.

For example, the application of deformation modelling requires the estimation of material behaviour to evaluate the permanent strain response under repeated loading. Studies at the Shell facility (Hofstra and Valkering, 1977) which led to the Shell design method for bituminous pavements showed that linear elastic theory did not agree well with pavement response, with the importance of temperature effects on bituminous pavements being clearly demonstrated. Studies of the fatigue life of full depth bituminous pavements (Ullidtz, 1982) concluded that, with respect to cracking, there was "a considerable difference between the predicted and the observed number of loads (at failure)", indicating the difficulties involved in comparing fatigue behaviour in the laboratory with that under accelerated full-scale loading.

Several studies (Vuong *et al.*, 1994) have found that deformation has occurred in the base layers rather than in the subgrade layers, which has cast some doubt on the applicability of many performance relationships which are based on the maximum vertical strain on the subgrade layer.

As the above discussion suggests, the primary application of APT has been the empirical comparison of different pavement configurations and materials under different loading configurations, the results of which form the basis of current pavement design and material selection procedures. A secondary application has been the evaluation of theoretical models of pavement response and material behaviour. By its nature, APT is not able to take account of the interaction of environmental factors and loads, and in particular the deterioration of pavement materials with exposure to sun, water and time. There is significant evidence that the environment in which a load is applied, especially with regard to the presence of moisture and extremes of temperature, has a major influence on its effect.

APT was pursued in Element 1 of the DIVINE Project because the main objective was to compare the performance of a well-defined flexible pavement under two suspension types and, as such, to "rate" the suspension systems. Such a study could not have been attempted via a long-term field trial because, apart from the time required to collect the data, control of the trafficking conditions (i.e. ensuring that the same load was applied to the same section of pavement by two different suspension systems), control of the environment and tight control over the construction process would have been impossible. On the other hand, it was imperative that the APT study was conducted in association with other studies,

not only in Element 1 (laboratory characterisation, suspension characterisation, etc.), but also with the other elements if an improved understanding of the interaction between the dynamic wheel load and the road was to be gained.

### A.3 Development of pavement condition analysis procedures

It was realised during the AASHO Road Test that an explicit definition of "terminal condition" was required if any design procedures arising from the test were to have widespread application. It was also more widely accepted that roads were constructed for the benefit of the road user who was ultimately the judge as to whether a certain pavement condition was acceptable or not. Panels of road users were therefore asked to drive over specific sections of road and rate the condition between 0 (impassable at normal speed) and 5 (perfect). They were also asked whether they considered the condition to be acceptable. This rating was termed the Present Serviceability Rating (PSR).

It was realised that it would be impracticable to have panels of drivers rate all roads, and so the subjective PSR was correlated with an objective measure of condition called the Present Serviceability Index (PSI).

The original equation derived from the AASHO Road Test for flexible pavements was:

$$PSI = 5.03 - 1.9 \times \log(1 + SV) - 1.38 \times RD^2 - 0.01 \times \sqrt{(C + P)}$$

where

SV = slope variance (slope expressed in  $\mu$ rad and measured over a distance of 1 foot);

RD = rut depth in both wheeltracks (inches) measured with a 4-foot straight edge;

C = major cracking (square feet cracked per 1 000 square feet area); and

P = area of bituminous patching (square feet).

It has, however, been found that cracking, rutting and patching counted for only 5 per cent of the PSI value. PSI values reported today by most roadmeters (in contrast to profilometers) are based only on the profile, or rather on some profile statistic converted to PSI through a correlation to the abbreviated PSI formula:

$$PSI = 5.03 - \log(1 + SV)$$

Other functional performance indices which have been related to PSI include the Canadian-based Riding Comfort Index (RCI) (Rilett *et al.*, 1989).

In simple terms, road unevenness, or roughness, is a measure of a driver's perception of the variation in the surface profile along the road. As a functional performance measure, it has the distinct advantage of being able to be objectively measured by a standardised measuring device such as a profilometer, as the measured roughness is not influenced by the ride characteristics of the host vehicle. A commonly used measure of road unevenness, the International Roughness Index (IRI in mm/m), "is a scale for roughness based on the response of a generic motor vehicle to roughness of the road surface. Its true value is determined by obtaining a suitably accurate measurement of the profile of the road,

processing it through an algorithm that simulates the way a reference vehicle would respond to the roughness inputs, and accumulating the suspension travel. Thus, it mathematically duplicates a roadmeter” (Gillespie, 1992).

It is acknowledged that road roughness may not always be an appropriate measure for assessing when and what types of pavement maintenance and rehabilitation are required during a pavement's life-cycle. Specific pavement distress measures such as rutting and cracking are more appropriate for this function.

#### **A.4 Development of bridge design with regard to dynamic loading**

The situation has developed somewhat differently for bridges than for pavements. It became apparent in the middle of the last century that it was not sufficient to consider only the static load effects in the case of railway bridges. In 1847, after a series of railway bridge collapses in the United Kingdom, a study was commissioned on the effects of dynamic loads produced by railway vehicles. The study not only attempted a solution to the theoretical problem of the response of a beam to the passage of a force and/or mass moving at a given speed, but also carried out what were probably the first tests on a model bridge and in-service bridges. As a result of this and later work, the Dynamic Load Allowance for railway bridge loads was defined as being a function of the bridge average span.

The first codes dealing with highway bridge loading at the beginning of the century made use of the philosophy established for railway bridges. However, as early as 1931, an American Society of Civil Engineers (ASCE) committee found that "there is no scientific reason for the average bridge span being the parameter to be considered when dealing with the effects of dynamic wheel loads on the bridge response". Forty years later, experimental and computational methods were sufficiently well developed to prove that the dynamic bridge response to the actions of heavy vehicles is mainly a function of, on the one hand, the bridge fundamental natural frequency and, on the other hand, the frequency content and magnitude of the dynamic wheel loads exerted by the vehicle during its passage over the bridge. Pioneering experimental work was carried out some ten years later in Canada and Switzerland on the matter of frequency-matching and quasi-resonance. As a result, bridge design codes were developed in which the Dynamic Bridge Allowance was a function of the bridge fundamental frequency. While the bridge fundamental frequency is basically constant and is mainly independent of other parameters, the vehicle's dynamic wheel load frequency content and magnitude depends on the vehicle suspension system and speed as well as the pavement longitudinal profile.

The newly developed bridge loading codes, such as Eurocode 1, Part 3, SIA 160 (1989), BS 5400 and the 1992 Austroads Bridge Design Code, include provision for dynamic loads based on the multiple experimental and analytical studies carried out in several countries. Nevertheless, further work is necessary in order to bring about a greater understanding of the vehicle/bridge interaction and to account for vehicle types, suspensions and surface roughness.

## BIBLIOGRAPHY

- AMERICAN SOCIETY FOR CIVIL ENGINEERS (1931), "Impact in Highway Bridges", Final Report of the Special Committee, with discussion, Trans. ASCE 95, Paper No.1786.
- BARBOUR, I. A. (1993), *Multiple-sensor Weigh-in-motion Trials at Abingdon (A34)*, Research Report 375. Transport Research Laboratory, Crowthorne.
- COLLOP, A. C. and D. CEBON (1995), *A Parametric Study of Factors Affecting Flexible Pavement Performance*, Department of Engineering, University of Cambridge, Cambridge.
- GILLESPIE, T. D. (1992), "Everything You Always Wanted to Know about the IRI But Were Afraid to Ask", paper presented at the Road Profile Users group Meeting 22-24 September Lincoln Nebraska.
- HIGHWAY RESEARCH BOARD (1962), *The AASHO Road Test. Report 7: Summary Report*, National Academy of Sciences - National Research Council Publication 1061, Washington DC.
- HOFSTRA, A. and C. P. VALKERING (1977), "The Modulus of Asphalt Layers at High Temperatures; Comparison of Laboratory Measurements under Simulated Traffic Conditions with Theory", *Proc. 3rd International Conference on the Structural Design of Asphalt Pavements*. pp. 430-43. University of Michigan, Ann Arbor.
- JAMESON, G. W., SHARP, K. G. and R. YEO (1992), *Cement-treated Crushed Rock Fatigue under Accelerated Loading: the Mulgrave,(Victoria) ALF Trial, 1989/1991*, Australian Road Research Board, Research Report, ARR No. 229, July. ARRB.
- KENIS, W. J. (1978), *VESYS IIM Predictive Design Procedure, Users' Manual*, FHWA Report RD77-154. FHWA, Washington DC.
- METCALF, J. B. (1996), "Application of Full-scale Accelerated Pavement Testing", NCHRP Synthesis 235, Transportation Research Board. National Research Council, Washington DC.
- OECD ROAD TRANSPORT RESEARCH (1985), *Full-scale Pavement Tests*, OECD, Paris.
- OECD ROAD TRANSPORT RESEARCH (1992), *Dynamic Loading of Pavements*, OECD, Paris.
- PORTER, O. J. (1942), "Foundations for Flexible Pavements", *Proceedings of the Highway Research Board*, 22, pp. 100-36. TRB, Washington DC.
- RILETT, L. R., HUTCHINSON, B. G., and R. C. G. HAAS (1989), "Cost Allocation Implications of Flexible Pavement Deterioration Models", *Transportation Research Record 1215, Pavement Management and Rehabilitation.*, pp. 31-42. Transport Research Board, National Research Council, Washington DC.
- ROAD RESEARCH LABORATORY (1960) *A Guide to the Structural Design of Pavements for New Roads*, Road Note 29. TRL, Crowthorne.

SCAZZIGA, I., DUMONT, A. G. and W. KNOBEL (1987), "Strain Measurements in Bituminous Layers", *Proceedings of the 6th International Conference on the Structural Design of Asphalt Pavements*, pp. 574-89. University of Michigan, Ann Arbor.

SHELL (1978), *Shell Pavement Design Manual*.

ULLIDTZ, P. (1982), "Predicting Pavement Response and Performance from Full-scale Testing", International Colloquium on Full Scale Pavement Tests, Institute fur Strassen-, Eisenbahn- und Felsbau an der Eidgenossischen Tehnischen Hochschule, pp. 129-46, ETH, Zurich

ULLIDTZ, P. (1987), *Pavement Analysis*, Developments in Civil Engineering, 19. Elsevier.

VUONG, B. T., SHARP, K. G., BARAN, E. and N. J. VERTESSY (1994), The Performance of Fine Grained Marginal Material under Accelerated Loading, *Proceedings of the 17th ARRB Conference*, Gold Coast 17(2), August, pp. 145-64. ARRB.

## ANNEX B FACILITIES AND EQUIPMENT USED

International co-operation facilitated by the OECD enabled the most appropriate vehicle, pavement and bridge research facilities to focus on a single set of project aims. The following sections describe the major facilities used in the DIVINE Project.

### B.1 The Canterbury Accelerated Pavement Testing Indoor Facility (CAPTIF)

Element 1 was as an accelerated pavement test under controlled conditions to establish pavement wear under different suspension types. Using the design of the experiment as the basis for a specification of requirements, a survey was made of candidate test facilities. As a result, CAPTIF, located in Christchurch, New Zealand, was selected.

CAPTIF was designed to apply loads that have dynamic characteristics similar to those of the in-service vehicle fleet to full-scale pavements and subgrades constructed in an annular track of 18.5 m mean diameter. The main feature of CAPTIF is the Simulated Loading and Vehicle Emulator (SLAVE). The two SLAVE vehicles use representative heavy vehicle suspension components. Different suspension types can be fitted to the vehicles. The primary characteristics of the SLAVE are summarised in Table B.1.

**Table B.1. Characteristics of the SLAVE**

Item	Characteristic
Test wheels	Dual- or single-tyres; standard or wide single; bias or radial ply; tube or tubeless; maximum overall tyre diameter of 1.06 m
Mass of each vehicle	21-60 kN, (a test load of 49 kN was used in Element 1 of DIVINE)
Suspension	Air bag; multi-leaf steel spring; single or double parabolic
Power drive to wheel	Controlled variable hydraulic power to axle; bi-directional
Speed	0-50 km/h, programmable, accurate to 1 km/h -- a nominal test speed of 45 km/h was used in Element 1 of DIVINE
Radius of travel	9.26 m

The SLAVE "vehicles" are equipped with half-axle assemblies that can carry either single or dual-tyres (single tyres were used in the DIVINE experiment). The configuration of each vehicle, with respect to suspension type, wheel load, tyre type and tyre number, can be identical or different, the latter allowing for simultaneous testing of different load characteristics. Unlike other accelerated loading facilities, the SLAVE was designed to generate realistic dynamic wheel loads.

From the point of view of the DIVINE Project, one of the most important features of CAPTIF was the ability to apply two loading tracks to a test pavement, with sufficient separation between the tracks to provide clear separation of the pavement distress occurring in each track. For the DIVINE project, the SLAVE vehicles were fitted with examples of steel leaf suspension and air suspension systems.

The vehicle instrumentation comprised accelerometers mounted on both the sprung and unsprung masses of each vehicle and displacement transducers for measuring suspension displacements. The dynamic wheel forces were calculated by combining the two accelerometer signals, weighted by appropriate mass factors.

## **B.2 DIVINE test roads**

The CAPTIF accelerated tests carried out under controlled conditions were supplemented by full-scale tests utilising instrumented highway pavements. The DIVINE Project made comprehensive use of such full-scale tests in Element 2 and Element 5.

### ***B.2.1 Virttaa test site (Finland)***

The Virttaa test site is part of a 3 km long straight section of a two-lane public highway forming part of a temporary airfield for the Finnish Air Force. The site has a width of about 40 m and has previously been used for other studies of pavement response and behaviour. It was considered very suitable for the work in Element 2 because it had considerable amounts of high-quality pavement instrumentation already installed.

An area of the site was chosen which included two bituminous pavements, one with a thickness of 150 mm and the other with an 80 mm thickness. The pavement instrumentation comprised longitudinal and transverse strain measuring sensors at the top and bottom of the bituminous surface layer and a number of pressure cells located in the unbound materials and subgrade.

Instrumented vehicles (see Section B.4) were driven down the marked gauge line while simultaneous measurements were made of the dynamic loads applied by the vehicle and the stresses and strains generated in the pavement.

Two different bumps were used in the experiments: a long plywood bump, 4 m long and 50 mm high, designed to generate vehicle body bounce, and a short steel bump, 0.3 m long and 25 mm high, designed to generate axle hop (Figure B.1). Testing was also conducted with no bumps.

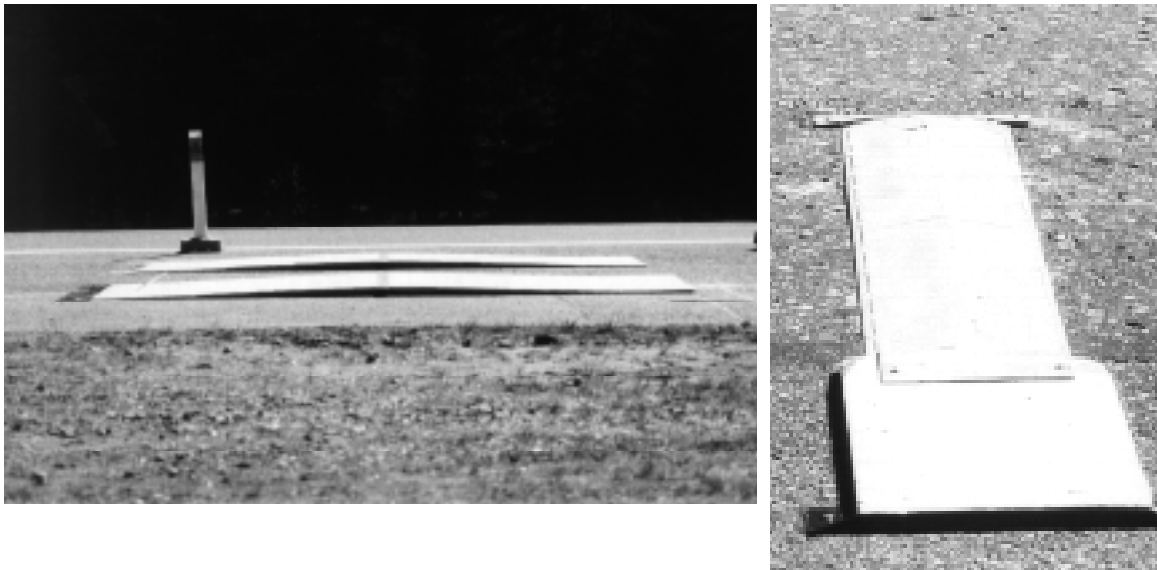
**Figure B.1. Long and short bumps used in Element 2**

### ***B.2.2 United States Federal Highway Administration (FHWA) test road***

The FHWA Test Road is located at the Turner-Fairbanks Highway Research Center in McLean, Virginia. Although the road is not part of the public network, it receives light traffic in its role as a site road. The pavement was similar to the thicker of the two Virttaa pavements, comprising 178 mm nominal thickness of asphaltic concrete construction. The pavement was laid for an experiment in 1991.

Using the same technique as that employed on the Virttaa pavement, 16 horizontal, longitudinal and transverse strain measurement gauges were installed in the near-side wheel path to record the strains generated at the top and bottom of the asphalt layer during the passage of a vehicle.

The NRC instrumented vehicle (see Section B.4) was also used at the FHWA test road, and this provided a link between the two sites for the experiment. Since differences in dynamic loading can be attributed not only to differences in road profile, but also to differences in vehicle speed, the FHWA tests were conducted at creep speed and at speeds of 15, 25, 35 and 45 km/h to take account of this. The FHWA tests were conducted using a similarly shaped but slightly longer bump than that used at the Virttaa test field.

### ***B.2.3 RN10 Trappes test road (France)***

Element 5 was particularly concerned with the dynamic traffic loads on highway pavements imposed by known test vehicles and by a normal traffic stream. Special attention was given to the identification of possible spatial repeatability in the patterns of these dynamic loads. In order to do this, a suitable test length of a public highway was required that could meet the following relatively stringent requirements:

- high traffic flow with a significant proportion of heavy goods vehicles (HGVs);

- straight and flat lane section, with mostly constant traffic speed and no congestion;
- pavement evenness representative of common highways; and
- good work-zone safety.

The RN10 at La Verrières, 35 km south-west of Paris near Trappes, is a straight, level, dual two-lane carriageway site carrying 30 000 vehicles per day, of which 25 per cent are HGVs. The pavement evenness was good with an IRI index of 1.71 mm/m. As part of the Element 5 experiment, a multiple-sensor WIM (MS-WIM) array of 24 piezoceramic strips (bars) manufactured by Transfibre was installed by Drouard. It was 36 m in total length with carefully selected spacings in the slow (right) lane of the Paris-bound carriageway. These were connected to three WIM electronic monitors -- manufactured by LEEM, supplied by VECTRA and operated by the LROP (Laboratoire Régional de l'Ouest Parisien) -- in order to measure the axle impact forces at different locations and to assess evidence of spatial repeatability (Figure B.2). A static weighing area used for enforcement by the police was located 5 km upstream of the test site, at which the true static loads of WIM-weighted HGVs were recorded and used to derive impact factors and dynamic increments.

**Figure B.2. Trappes test site used for Element 5 work**



The MS-WIM system was very carefully calibrated using, first, pre-weighed vehicles and then the NRC instrumented truck. Calibration checks were made regularly during the test programme.

Impact forces were measured by the WIM sensors for two instrumented vehicles -- the NRC truck and a German single-axle trailer supplied by the University of Hanover --, two commercial trucks supplied as a courtesy by Renault Véhicules Industriels and for pre-weighed HGVs in the traffic flow. Moreover a large number of HGVs in the traffic flow were recorded during a week and their static loads accurately estimated by the MS-WIM system.

### B.3 Test bridges used in Element 6

A total of seven bridges were instrumented in Element 6. These bridges were located in Switzerland (CH) and New South Wales, Australia (AUS). The main geometrical and dynamic parameters of the bridges are summarised in Table B.2 and a photograph of one of the short-span Australian bridges is shown in Figure B.3.

**Table B.2. Details of test bridges' main parameters**

Bridge (Country)	Max. Span (m)	Description	1st Freq. (Hz)	Damping (%)
Sort (CH)	70.0	5-span continuous prestressed concrete single-cell box girder	1.62	1.0
Deibüel (CH)	41.0	3-span continuous prestressed concrete single-cell box girder	3.01	0.8
Foss (CH)	31.0	3-span continuous prestressed concrete twin-cell box girder	4.44	1.6
Lawsons (AUS)	23.3	1-span prestressed concrete girder and reinforced concrete slab	5.1	1.0
Coxs (AUS)	11.0	4 simply supported steel girder and reinforced concrete slab spans	10.2	4.5
Camerons (AUS)	9.1	4 simply supported prestressed concrete plank spans	11.3	1.5
Cromarty (AUS)	9.0	3-span natural timber girders and timber deck planks	9.5	2.6

Source: Cantieni and Heywood, 1998

**Figure B.3. Camerons Creek bridge**



#### **B.4 Vehicles used in Elements 2, 3, 5 and 6**

In order to meet the stringent requirements of the DIVINE Project, it was necessary to conduct experiments in which dynamic loads applied by vehicles to infrastructure components could be measured simultaneously with the stresses, strains and deflections arising in those components. This required vehicles that were appropriately instrumented and capable of safe and effective use in controlled experimental conditions.

The DIVINE Project was fortunate in having access to several vehicles that had been specifically developed for these applications. These are described in the following sections.

##### ***B.4.1 National Research Council of Canada (NRC) vehicle***

The NRC vehicle is an instrumented 6-axle articulated goods vehicle consisting of a 3-axle tractor unit and a 3-axle tanker trailer with a tandem axle group and a “belly axle” (Figure B.4). The tanker configuration allowed the load on the axles to be readily controlled by adding or removing a fluid load from one or more of the tanker compartments. The vehicle, employing a cab-over-engine layout, is typical of those in use on highways in many parts of the world. Three features of the vehicle made it very suitable for use in the DIVINE experiment. First, the suspensions on all axles except the steering axle could be changed so that the vehicle could be effectively fitted with any combination of air, steel or rubber suspensions. This was particularly important in Element 6 where the requirement was to compare so-called “road-friendly” and “road-unfriendly” suspensions. Second, the vehicle was equipped with instrumentation on each of its axles to measure dynamic wheel loads and vehicle speeds. The wheel load instrumentation comprised two strain gauge bridges and two accelerometers per axle, configured as full bridge circuits, but installed in such a way as to be sensitive to shear force. Lastly, the “belly axle” could be lifted clear of the road at any time. This enabled the zero-load setting for the instrumentation on that axle to be made very precisely, thus allowing the absolute value of load on the axle to be known very precisely. This was a particularly important requirement for Elements 2 and 5 as it was necessary in each to apply known loads to the road surface and to measure the simultaneous responses from instrumentation installed in the road.

**Figure B.4. NRC instrumented vehicle**



#### ***B.4.2 Transport Research Laboratory of UK (TRL) vehicle***

The TRL Ford Cargo used in Elements 2 and 3 is a 2-axle, 17.5 tonne gross weight vehicle fitted with a steel sprung drive axle and steel sprung steering axle (Figure B.5). Hydraulic dampers were fitted to each axle. The drive axle was fitted with a steel leaf suspension system comprising a 3-leaf upper spring and a 2-leaf lower spring acting as a helper spring under heavier loads. The steering axle was fitted with a 2-leaf spring.

**Figure B.5. TRL instrumented vehicle**



The axle-mounted instrumentation consisted of two strain gauges mounted on the upper and lower surfaces of the axle between the spring and the hub to measure bending strains and two accelerometers to estimate the inertial forces of the axle mass outboard of the strain gauges. The outputs of these transducers could be combined to measure the instantaneous vertical force applied to the road by the wheel on the instrumented axle.

#### ***B.4.3 Hannover (Germany) test trailer***

The University of Hannover vehicle (Figure B.6) is made up of a single-axle instrumented trailer and a two-axle rigid truck. Its current configuration allows either air or steel suspension, as well as single or dual tyres to be fitted. The axle is equipped with accelerometers to measure the applied dynamic loads, and the trailer can be raised hydraulically in order to check the instrumentation and ensure a precise zero setting. The axle load may be varied from approximately 2.5 to 8.5 tonnes by loading or unloading it with concrete blocks. In the DIVINE experiment, the trailer was used to re-check the calibration of the WIM sensor array used at the test site on RN10, near Trappes, France.

**Figure B.6 University of Hannover trailer**



**B.4.4 Australian test vehicles**

The test vehicles used in Australia -- 6-axle articulated tipper trucks (Figure B.7) -- were employed on the dynamic assessment of short-span bridges. Each was loaded to its legal limit, namely a gross weight of 425 kN, with a 60 kN steer axle, 165 kN on the tandem axles and 200 kN on the tridem axles. The trailers were modified so that they could be equipped with either BPW air suspensions or with 8-leaf steel suspensions supplied by York Australia.

**Figure B.7. Air-suspended Australian test vehicle crossing Lawsons Creek Bridge**



The test vehicles were instrumented to measure the dynamic wheel force for each of the trailer axles. Each wheel position of the trailing tridem group was fitted with strain gauges to measure the principal strains due to shear in the stub axle and with accelerometers to measure the acceleration of the outboard mass. The combined signals were transmitted directly to a data acquisition system for recording and later analysis. The instrumented and calibrated axles were supplied by BPW, Germany.

## B.5 The Laser RST Portable

The Laser RST Portable is a high-speed profilometer designed in Sweden, based on the GM profilometer principle developed by General Motors Research Laboratories during the 60's.

As a vehicle hosting the Laser RST Portable is driven along a road, measurements are taken of the vertical distance between a point on the host vehicle and the road surface (using a distance measuring laser unit), the vertical acceleration of this point (using an accelerometer) and the distance travelled along the road. The data is collected, analysed and stored by an on board computer.

The longitudinal profile is given in amplitude samples every 50 mm along the road and profile measurement can be carried out at varying speed in the range of 15 to 90 km/h. This means that the measurement vehicle can follow the speed and speed variations of the traffic without being disturbed by the traffic or causing traffic disturbances itself.

The special feature of the Laser RST Portable is that it can easily be transported e.g. by air and be used hooked on to the draw bar of almost any vehicle (see Figure B.8) in some cases requiring minor adaptation work.

**Figure B.8. The Laser RST Portable**



**ANNEX C  
GLOSSARY OF ABBREVIATIONS**

AASHO	American Association of State Highway Officials
APT	Accelerated Pavement Test
CAPTIF	Canterbury Accelerated Pavement Testing Indoor Facility (New Zealand)
CBR	California Bearing Ratio
CV	Coefficient of Variation
DIVINE	Dynamic Interaction between Vehicles and Infrastructure Experiment
DLA	Dynamic Load Allowance
DLC	Dynamic Load Coefficient
ESA(L)	Equivalent Standard Axle (Load)
IRI	International Roughness Index
IWP	Inner Wheel Path (Air spring suspension for Element 1 APT)
FHWA	Federal Highway Administration (United States)
FWD	Falling Weight Deflectometer
LCC	Life Cycle Costing
APL	Longitudinal Profile Analysers (Analyseur de Profil en Long)
LCPC	Laboratoire Central des Ponts et Chaussées (France)
LROP	Laboratoire Régional de l'Ouest Parisien
LTPP	Long Term Pavement Performance
MESAL	Million Equivalent Standard Axle Loads
MMOP	Mathematical Model of Pavement Performance
NCHRP	US National Co-operative Highway Research Program
NPV	Net Present Value
NRC	National Research Council (Canada)
OWP	Outer Wheel Path (Steel leaf spring suspension for Element 1 APT)
PMS	Pavement Management Systems
PSD	Power Spectral Density
PSI	Present Serviceability Index
PSR	Present Serviceability Rating
RCI	Riding Comfort Index
RMS	Root Mean Square
RRL	Road Research Laboratory (United Kingdom) (now TRL)
RTR	OECD Road Transport and Intermodal Linkages Research Programme
SSS	Simultaneous Sinusoidal Sweep
TNO	Road-Vehicles Research Institute (Netherlands)
TRL	Transport Research Laboratory (United Kingdom)
VESYS	Viscoelastic Structural Subsystem
VSD	Vertical Surface Deformation
VTT	Technical Research Centre (Finland)
(MS-)WIM	(Multiple-sensor) Weigh-in-motion
WLPPM	Whole Life Pavement Performance Model

**ANNEX D****LIST OF PARTICIPANTS****Executive Committee****Chairman: Mr. Jørgen Christensen (Denmark)**

Denmark	Mr. J. Christensen
France	Mr. J.-F. Coste
Netherlands	Dr. C. van Theylingen Mr. P. Mazure (Retired)
United Kingdom	Mr. G. Bowskill
United States	Mr. R. Betsold

**Scientific Expert Group****Chairman: Dr. Peter Sweatman (Australia)**

Australia	Dr. R. J. Heywood Mr. K. Sharp Dr. P. Sweatman
Austria	Mr. G. Fichtl Dr. J. Litzka Mr. H. Tieffenbacher
Belgium	Mr. A. De Henau
Canada	Mr. J. Woodrooffe
Denmark	Mr. E. Larsen
Finland	Mr. M. Huhtala
France	Mr. B. Jacob

Germany	Dr.-Ing. W. D. Hahn Mr. M. Stanzel
Hungary	Mr. C. Koren Mr. L. Palkovics Dipl.-Ing. S. Tombor
Japan	Mr. T. Ikeda Dr. T. Maruyama
Netherlands	Mr. R. J. Henny Mr. B. Hoogvelt
New Zealand	Dr. J. de Pont Dr. B. D. Pidwerbesky
Sweden	Mr. J. Aurell Mr. G. Magnusson
Switzerland	Dr. R. Cantieni Mr. A.-G. Dumont Dr. W. Krebs
United Kingdom	Mr. R. Addis Dr. C. Mitchell
United States	Mr. W. J. Kenis Dr. W. Wang
OECD	Mrs. V. Feypel-de la Beaumelle Mr. B. Ficherouille Ms. M-D. Gorrigan Mr. P. Hasson Mr. B. Horn Mr. W. Hübner Mr. C. Levins Dr. A. Ockwell

#### **Additional Researchers**

Australia	Dr. P. S. Baburamani Mr. G. Jameson Mr. J. R. Johnson-Clarke Mr. S. McFarlane Mr. M. Moffatt Mr. D. Swenson Mr. N. J. Vertessy
-----------	--

Canada	Mr. R. Yeo Mr. E. Feser Mr. P. Leblanc Mr. S. McLoud Dr. N. Mrad Mr. Y. Séguin Mr. R. Senn
Czech Republic	Mr. V. Bily
Finland	Mr. R. Alkio Mr. P. Halonen Mr. V. Miettinen Mr. J. Pihlajamaki
France	Mr. O. Brunet Mr. V. Dolcemascolo Mr. P. Faucheur Mr. T. O'Connor
Netherlands	Mr. P. Ruijs
New Zealand	Mr. J. Devine Mr. A. Fussell Mr. B. Steven
Switzerland	Ms. S. Barella Dr. A. J. Felber
United Kingdom	Mr. I. Barbour Mr. L. Gyenes Mr. J. Hanley Mr. D. Jacklin Mrs. P. Lewis
United States	Mr. D. George Mr. J. Hammouda Ms. P. Minkle

The Project Managers were Messrs. Addis and Mitchell. Members of the Editorial Committee were Messrs. Addis, Kenis, Sharp, Sweatman and Woodrooffe. The final report was prepared by the OECD Secretariat.